

Revell AIRBUS A330-300 THAI AIRWAYS

04870-0389

© 2013 BY REVELL GmbH. A subsidiary of Hobbico, Inc.

PRINTED IN GERMANY



AIRBUS A330-300 THAI AIRWAYS

Ein zweistrahliges Großraumflugzeug (sog. „widebody“ / „two-aisle“), des europäischen Flugzeugherstellers Airbus, ist prädestiniert für die Mittel- und Langstrecke. Neben den beiden Turbofan-Triebwerken besitzt es wie alle modernen Verkehrsflugzeuge ein Zweimanncockpit. Der Erstflug fand am 2. November 1992 in der Version A330-300 statt. Die verkürzte Version, der 330-200 mit ihrer reduzierte Startmasse und geringer Verbrauch, hat auch sich in verschiedene Sektoren gut durchgesetzt, besonders beliebt ist diese Version bei Low cost carriers. Bemerkenswert ist der Verkaufserfolg dieses Modells - im Jahr 2008 erreichte der Airbus A330 die Anzahl von 1000 Bestellungen. Bis Mai 2013 wurden 984 von 1246 bestellten Flugzeugen dieses Typs ausgeliefert, von denen derzeit noch 972 in Betrieb sind. Die 1000sender Marke wurde im Juli 2013 erreicht, d.h. aktuell wurden bisher mit diesem Flugzeugtyp über 25 Mio. Flugstunden auf 5,5 Mio. Flügen mit Airlines weltweit absolviert. Viele technische Neuerungen finden sich im A330. Unter anderem: ein digitales Fly-by-wire-Flugkontrollsystem, das erstmals bei einem Großraumflugzeug angewandt wurde, ebenso wie ein Side stick an Stelle eines Steuerhorns. Auch wurde mit einem sog. Glas Cockpit mit CRT-beziehungsweise später LCD-Bildschirmen ausgeliefert, parallel wurden die analogen Instrumente reduziert. Später wurden auch die analogen „Back-up“-Instrumente durch ein zentrales Kombiinstrument ersetzt. Der Airbus A330 besitzt außerdem ein sogenanntes FADEC-System, bei dem die Triebwerkskontrolle und -überwachung von einem Computer übernommen werden. Insgesamt werden drei verschiedene Triebwerke eingesetzt: das General Electric CF6-80E, das PW4000-100 von Pratt Whitney und das Rolls-Royce Trent 700. Die letzten zwei wurden speziell für die A330 entwickelt. Thai Airways verfügt über insgesamt 26 Maschinen, 12 davon mit je 305 Sitzplätzen (263 Eco, 42 Royal Silk), 14 mit je 299 Sitzplätzen (263 Eco, 36 Royal Silk). Der Airbus zeichnet sich vor allem durch seine vergleichsweise hohe Wirtschaftlichkeit aus, was seinen weltweiten Erfolg berechtigt. Die Kosten für einen A330-300, liegen je nach Triebwerk Option, zwischen 200 und 222 Millionen US-Dollar. Der A330 wird durch den brandneuen A350 in der Airbus Produktionslinie ersetzt.

Länge :	63,66m
Spannweite :	60,30m
Höhe :	16,82m
Kabinenbreite :	5,28m
Reichweite :	10.500 km
Reisegeschwindigkeit :	870 km/h
Höchstgeschwindigkeit :	912 km/h
Triebwerk Leistung:	von 283 bis 316 kN

AIRBUS A330-300 THAI AIRWAYS

The A330 is a so-called „Wide Body“ / „Two-Aisle“ high capacity twin-engine aircraft from the European aircraft manufacturer Airbus. It is equally suitable for medium or long-haul routes. As well as two turbofan engines it has like most modern airliners, a two-man cockpit. The A330-300 undertook its maiden flight on 2 November 1992. The shortened version the 330-200 with its reduced take-off weight and low fuel consumption has also established itself in other sectors. This version is especially popular with „Low Cost Carriers“. The sales success of this model is particularly noteworthy - in 2008, Airbus achieved a total of 1000 orders for the A330. By May 2013, a total of 984 of the 1246 aircraft on order had been delivered of which 972 are still in service. The 1000th mark was achieved in July 2013, which means that to date over 25 million flight hours during 5.5 million flights have been flown by airlines worldwide on this particular type of aircraft. The A330 has many technical innovations, including a digital fly-by-wire flight control system. This was the first use of such a system in a wide-body passenger aircraft and included a side stick controller instead of the usual LCD control column. The instrument panel was also fitted with CRT and later LCD screens – the so-called glass cockpit. The number of analogue instruments was consequently reduced. Analogue „back-up“ instruments were also later replaced by a central instrument cluster. The Airbus A330 also has a so-called „FADEC“ system in which engine control and monitoring are performed by a computer. In all, three different types of engines can be used: the General Electric CF6-80E, the Pratt & Whitney PW4000-100 and the Rolls-Royce Trent 700. The last two were developed specifically for the A330. Thai Airways has a total of 26 machines, 12 of which have 305 seats (263 Economy, 42 Royal Silk) and 14 each with 299 seats (263 Economy, 36 Royal Silk). This Airbus distinguishes itself above all through its relatively high cost-effectiveness, which has bestowed it with worldwide success. An A330-300 costs - depending on the engine option - between 200 and 222 million U.S. dollars. The A330 is being replaced by the brand new A350 in the Airbus product range.

Length :	63.66m (208ft 10ins)
Wingspan :	60.30m (197ft 10ins)
Height :	16.82m (55ft 2ins)
Cabin Width :	5.28m (17ft 4ins)
Range :	10500 km (6520 miles)
Cruising Speed :	870 km/h (540 mph)
Maximum Speed :	912 km/h (566 mph)
Engine Power Rating	Between 283 and 316 kN

Form hergestellt und im Eigentum von Revell GmbH. Wiederrechtliche Nachahmungen werden gerichtlich verfolgt.
 Ce produit est propriété de la société Revell GmbH. Toute utilisation ou duplication frauduleuse sera l'objet de poursuites en justice.
 Modelado y en propiedad de Revell GmbH. Imitaciones ilícitas serán perseguidas por la ley.
 Forma produsita dalla Revell GmbH e di proprietà della stessa impresa, la qua e procederà legalmente contro ogni imitazione abusiva.
 Malli on Revell GmbH valmistama ja omistamassa. Laittomat kopioinnit tullaan puuttamaan oikeudellisin toimin.
 Formen e produsert og eies av Revell GmbH. Ettergjøring uten tillatelse vil bli genstand for rettslig forfølging.
 Produkcia i prawné własności firmy Revell GmbH. Nielegalne powtórzenie jest zabronione pod obojętnością odpowiedzialności sądowej.
 Model, Revell GmbH firmasının mülkiyeti altında imal edilmiştir. Kanuna aykırı taklitler mahkemeye takip edilecektir.
 A forma előállítását és a tulajdonjogát bírkozza a Revell GmbH. A jogellenes utánzatokat bíróságiag üződik.

Mould manufactured by and property of Revell GmbH. Ilegal imitations are subject to prosecution.
 Vorm vervaardigd door en eigendom van Revell GmbH. Onrechtmatige nabootsingen worden gerechtelijk vervolgd.
 Formas produsidas e de propriedade da Revell GmbH. Copias não autorizadas serão processadas juridicamente como determinado na lei.
 Modellén tillverkad av och tillhör Revell GmbH. All kopiering beivras enligt lagen om upphovsrätt.
 Formen e framstillet af Revell GmbH som også har ejendomsret. Lovlovlige efterligninger forfølges.
 Model e proizvodjena i vlastnosti samostalnosti firme Revell GmbH. Protivovlastne povzela e presледovana e sudbeno povredilo.
 H kopien proizvodnje zabranjeno. Nelegalne kopiranje je zabranjeno pod obojętnością odpowiedzialności sądowej.
 Tüm hak müdahale firması Revell GmbH a je jermi vlaštničtva. Prati nezakonitimi napodobitvami se bude postopoval sodni sodstvo.
 Forma je proizvedena in je v lastništvo Revell GmbH. Neovlaštene kopije bodo pravno kažnjane.

Verwendete Symbole / Used Symbols

Bitte beachten Sie folgende Symbole, die in den nachfolgenden Baustufen verwendet werden.
Veillez noter les symboles indiqués ci-dessous, qui sont utilisés dans les étapes suivantes du montage.
 Sirvane tener en cuenta los símbolos facilitados a continuación, a utilizar en las siguientes fases de construcción.
Si prega di fare attenzione ai seguenti simboli che vengono usati nei susseguenti stadi di costruzione.
 Huomioi seuraavat symbolit, jotta käytetään seuraavissa kokoomaisvaiheissa.
Leggiatele til symbolene som benyttes i monteringsstrinene som følger.
 Prosze zwracać na następujące symbole, które są użyte w poniższych etapach montażowych.
Daha sonraki montaj basamaklarında kullanılabacak olan, aşağıdaki sembollere lütfen dikkat edin.
 Кérjük, hogy a következő szimbólumokat, melyek az alábbi építési fókoban alkalmazásra kerülnek, vegyék figyelembe.

Please note the following symbols, which are used in the following construction stages.
Neem a.u.b. de volgende symbolen in acht, die in de onderstaande bouwfases worden gebruikt.
 Por favor, preste atenção aos símbolos que seguem pois os mesmos serão usados nas próximas etapas de montagem.
Observer: Nedanstående piktogram används i de följande arbetsmomenten.
 Leg venligst märke till följande symboler, som benyttes i de följande byggfaser.
Позначається, обратите внимание на следующие символы, которые используются в последующих операциях сборки.
 Παρακαλώ προσέξτε τα παρακάτω σύμβολα, τα οποία χρησιμοποιούνται στις παρακάτω βαθμίδες συναρμολόγησης.
Objezte prosim na dále uvedené symboly, které se používají v následujících konstrukčních stupních.
 Prosimo za Vašu pozornost na sledeče simbole ki se uporabljajo v naslednjih korakih gradbe.



Abziehbild in Wasser einweichen und anbringen
 Soak and apply decals
 Mouiller et appliquer les décalcomanies
 Transfer in water even laten weken en aanbrengen
 Remojar y aplicar las calcomanías
 Pör de molho em água e aplicar o decalque
 Immergere in acqua ed applicare decalcomanie
 Blöt och fäst dekallerna
 Kosteuta siirtokuva vedessä ja aseta paikalleen
 Fukt motvett i varmt vatt och för det över på modellen
 Dyppe bildet i vann og sett det på
 Переводную картинку намочить и нанести
 Zmkićzyć kalkomanie w wodzie a następnie nakleić
 βουτήξτε τη χαλκομανία στο νερό και τοποθετήστε την
 Çikartmayı sudu yumuşatın ve koyun
 Öbtsik namočit ve vodě a umistit
 a matricát vizben beázatni és felhelyezni
 Preslaiká potopiti v vodo in zatem nanašati



Anzahl der Arbeitsgänge
 Number of working steps
 Nombre d'étapes de travail
 Het aantal bouwstappen
 Número de operaciones de trabajo
 Número de etapas de trabalho
 Numero di passaggi
 Antal arbetsmoment
 Työvähiiden lukumäärä
 Antal arbeidstrinn
 Antall arbeidstrinn
 Количество операций
 Liczba operacji
 Цифры операций
 Αριθμός των εργασιών
 İş safhalarının sayısı
 Počet pracovnich operaci
 a munkafolyamatok száma
 Številka koraka montaže



Kleben
 Glue
 Coller
 Lijmen
 Engomar
 Colar
 Incollare
 Limmas
 Liimaa
 Limes
 Lim
 Клеить
 Przykleić
 η κολλημα
 Yapıştırma
 Lepení
 ragasztani
 Lepiti



Nicht kleben
 Don't glue
 Ne pas coller
 Niet lijmen
 No engomar
 Não colar
 Non incollare
 Limmas ej
 Älä liimaa
 Skal IKKE limes
 Ikke lim
 Не клеить
 Nie przyklejać
 μη κολλάτε
 Yapıştırılmayın
 Nelepit
 nem szabad ragasztani
 Ne lepiti



Wahlweise
 Optional
 Facultatit
 Naar keuze
 No engomar
 Alternado
 Facoltativo
 Valfritt
 Vaihtoehtoisesti
 Valgfritt
 Tape
 Valgfritt
 Tape
 Na выбор
 Do wyboru
 envalaktiká
 Seçmeli
 Volitelné
 tetszés szerinti
 način izbire



Klebeband
 Adhesive tape
 Dévador de ruban adhésif
 Plakband
 Cinta adhesiva
 Fita adesiva
 Nastro adesivo
 Tejp
 Teippi
 Poista
 Fjerm
 Udalить
 Asonuac
 απομακρύνετε
 Temizleyin
 Odstraniti
 eltávolítani
 Ostraniti



Entfernen
 Remove
 Détacher
 Verwijderen
 Sacar
 Retirar
 Eliminare
 Tag loss
 Poista
 Fjern
 Udalить
 Asonuac
 απομακρύνετε
 Temizleyin
 Odstraniti
 eltávolítani
 Ostraniti



Klarsichtteile
 Clear parts
 Pièces transparentes
 Transparente onderdelen
 Limpiar las piezas
 Peça transparente
 Parte transparente
 Genomsiktig detaljer
 Läpinäkyvät osat
 Glassklare deler
 Gjennomsiktige deler
 Прозрачные детали
 Elementy przezroczyste
 διαφανή εξαρτήματα
 Şeffaif parçalar
 Průzračné díly
 áttetsző alkatrészek
 Deli ki se jasno vide



Gleichen Vorgang auf der gegenüberliegenden Seite wiederholen
 Repeat same procedure on opposite side
 Opérer de la même façon sur l'autre face
 Zezelfde handeling herhalen aan de tegenoverliggende kant
 Realizar el mismo procedimiento en el lado opuesto
 Repetir o mesmo procedimento utilizado no lado oposto
 Stessa procedura sul lato opposto
 Upprepa proceduren på motsatta sidan
 Toista sama toimenpide kuten viereisellä sivulla
 Det samme arbejdet gentages på den modsatliggende side
 Gjenta prosedyren på siden tværs overfor
 Повторять такую же операцию на противоположной стороне
 Taki sam przebieg czynności powtórzyc na stronie przeciwniej
 επαναλάβετε την ίδια διαδικασία στην απέναντι πλευρά
 Aynı işlemleri karşı tarafa tekrarlayın
 Stejný postup zopakovat na protilehlé straně
 ugyanazati a folyamatot a szemben található oldalon megismételni
 Isti postopek ponoviti in na suprotni strani



Abbildung zusammengesetzter Teile
 Illustration of assembled parts
 Figure représentant les pièces assemblées
 Afbeelding van samengevoegde onderdelen
 Ilustración piezas ensambladas
 Figura representando peças encaixadas
 Ilustrazione delle parti assemblate
 Bilden visar delarna hopsett
 Kuvä yhteinliittyistä osista
 Ilustrasjonen viser de sammensatte delene
 Ilustrasjon, sammensatte deler
 Изображение смонтированных деталей
 Rysunek złożonych części
 απεικόνιση των συναρμολογημένων εξαρτημάτων
 Birleştirilen parçaların şekli
 Zobrazení sestavených dílů
 összeállításított alkatrészek ábrája
 Slika slopljenega dela



zur besseren Ausbalancierung mit einem Gewicht beschweren
 Add weight for improved stability
 Pour une mise en place correcte allourdir
 Voor evenwicht gewicht aanbrengen
 Colocar un peso para obtener un mejor equilibrio
 Utilizar um peso para melhor balanceamento
 Per un migliore bilanciamento metterci su un peso
 belasta med en vikt för bättre balansering
 paremman tasapainon saavuttamiseksi kuormita painolla
 Til bedre afbalansering vedhænges en vægt
 For bedre avbalansering - belast med en vekt
 für d'lyettere utbalanseringa položiti tež
 dla lepszego wyównoważenia obciążyc ciężarkiem
 για την καλύτερη αντιστάθμιση τοποθετήστε ένα βάρος
 Daha iyi dengelemek için bir ağırlık koyun
 Za účelem lepšího vyvážení zatížiti závažím
 a jobb kiegyenlítés érdekében egy nehezékkal ellátni
 Zarádi boljše ravnoteže postaviti kontratežo z tegom



Bauteile trocken lassen
 Allow the parts to dry
 Laisser sécher les pièces
 Onderdelen laten drogen
 Dejar secar las piezas
 Deixar secar os componentes
 Far asciugarsi i componenti
 Anna osien kuivua
 La délene tørke
 Lad komponenterne tørre
 Låt byggdelarna torka
 Дать деталям высохнуть
 Części pozostawić do wyschnięcia
 Yarı parçalarını kurumaya bırakınız
 Alkatrészeket hagyja száradni
 Jednotlivé díly nechte zaschnout
 Pustite da sestavni deli posušijo

- *** Nicht enthalten
Not included
Non fourni
- Behoort niet tot de levering
No incluido
Non compresi
- Não incluído
Ikke medsendt
İngår ej
- Ikke inkluderet
Eivät sisälly
Don't onmpirelambévetai
- He содержится
Nem tartalmazza
Nie zawiera
- Ni vsebavano
Icerisinde bulunmamaktadır
Neni obsaženo

Beiliegenden Sicherheitstext beachten / Please note the enclosed safety advice

D: Beiliegenden Sicherheitstext beachten und nachschlagebereit halten.
 GB: Please note the enclosed safety advice and keep safe for later reference.
F: Respecter les consignes de sécurité ci-jointes et les conserver à portée de main.
 NL: Houdt u aan de bijgaande veiligheidsinstructies en hou deze steeds bij de hand.
E: Observar y siempre tener a disposición este texto de seguridad adjunto.
 I. Seguire le avvertenze di sicurezza allegate e tenerle a portata di mano.
P: Ter em atenção o texto de segurança anexo e guardá-lo para consulta.
 S: Beakta bifogad säkerhetstext och håll den i beredskap.
FIN: Huomioi ja säilytä ohjeet varoitukset.

DK: Overhold vedlagte sikkerhedsanvisninger og hav dem liggende i nærheden.
N: Ha alltid vedlagt sikkerhetstekst klar til bruk.
 PL: Sobлюдajty przylagaznny tekst p technice bezopasnosti, khranit' ego v legko dostupnom meste.
RU: Stosować się do załączonej karty bezpieczeństwa i mieć ją stale do wglądu.
 GR: Προσέξτε τις συνημμένες υποδείξεις ασφαλείας και φυλάξτε τις έτσι ώστε να τις έχετε πάντα σε διάθεσή σας.
TR: Ekteki güvenliik talimatlarıñnı dikkate alıpy, bakabilecekiniz bir sekilde muafaza ediniz.
 CZ: Dbejte na pñiloženú bezpečnostní text a mějte jej pñipravený na dosah.
H: A mellékelt biztonsági szöveget vegye figyelembe és tartsa fellapozásra készen!
 SLO: Priložena varnostna navodila izvajajte in jih hranite na vsem dostopnem mestu.

Dieser Bausatz wurde in mehrfachen Qualitäts- und Gewichtskontrollen auf Vollständigkeit überprüft. Reklamationen können nur bearbeitet werden, wenn die **Bauanleitung**, das aus der Kartonage herausgeschnittene **EAN-Strichcode-Feld** und der **Kassenbon** eingeschickt werden. Bitte haben Sie Verständnis dafür, dass wir nur Gewährleistung bei aktuellen Artikeln übernehmen können, die im Zeitraum der letzten 24 Monate erworben worden sind. **Unfrei eingelegte Reklamationssendungen werden von uns nicht angenommen!**
 Einzelteile für Umbauten können gegen Vorkasse erworben werden. * Unsere Adresse: Revell GmbH, Abteilung X, Henschelstr. 20-30, 32257 Bünde. Dieser Directservice gilt für die Länder: Deutschland, Benelux, Österreich, Frankreich, Großbritannien. Reklamationen aus den übrigen Ländern werden über die jeweiligen Distributeure abgewickelt. Bitte kontaktieren Sie Ihren Händler.

Afin de vous donner entière satisfaction et pour nous assurer que tous les éléments nécessaires au montage de votre maquette sont présents dans la boîte, cet article a subi dans son intégralité divers contrôles qualitatifs ainsi que des contrôle de poids.
 Si toutefois vous deviez nous faire part de certaines réclamations, nous vous prions de bien vouloir vous adresser à votre revendeur habituel, muni de la notice de montage, du code EAN découpé sur la boîte, ainsi que de votre ticket de caisse.
 Le SAV ne sera assuré que pour les articles ayant été acquis depuis moins de 24 mois.
 Les pièces de rechange utilisées pour la transformation de maquettes pourront être obtenues en pré-paiement. Dans le cas où vous n'obtiendriez pas satisfaction, vous pouvez vous adresser directement à notre service SAV à l'adresse suivante: REVELL GmbH, Abteilung X, Henschelstraße 20-30, D-32257 Bünde cw Revell GmbH, 14 B, rue du Chapeau Rouge, F-21000 Dijon, France.
 Pour tous les autres marchés, merci de prendre contact avec votre détaillant ou distributeur.

This Model Kit has been subject to extensive quality and weight checks during the manufacturing process to ensure it leaves our warehouse in perfect condition. We are only able to process applications for missing parts if the following procedure is followed. In all cases the following will be required before we are able to process any request: Original receipt (proof of purchase) original instruction sheets (will be returned) and the bar code cut out of the box. We may not be able to process requests for products that have been discontinued for more than 24 months. Products that are returned directly to us without prior authorisation by a company representative will not be accepted and returned to sender. Replacement parts for conversion or spares will continue to be available however they will incur a handling charge. Please write to: Department X Revell GmbH, Henschelstr. 20-30, 32257 Bünde.
This direct Service is only available in the following markets: Germany, Benelux, Austria, France & Great Britain, Revell GmbH, Orchard Mews, 18c High Street, Tring, Herts., HP23 5AH, Great Britain.
For all other markets please contact your local dealer or distributor directly.

Deze bouwdoos werd diverse malen volledig gecontroleerd op kwaliteit en gewicht. Klachten slechts in behandeling worden genomen indien de bouwhandleiding, de uit de doos geknipte EAN - streepjescode en de kassabon zijn meegezonden. Wij vragen om uw begrip dat wij alleen garantie kunnen geven voor huidige artikelen die binnen een periode van de laatste 24 maanden zijn gekocht. Onvolledig ingezonden klachten kunnen niet in behandeling worden genomen. Onderdelen voor ombouw kunnen tegen vooruitbetaling gekocht worden.
 Ons adres is: Revell GmbH, Afdeling X, Henschelstrasse 20-30, 32257 Bünde, Duitsland. Deze directe service geldt alleen voor de volgende landen: Duitsland, Benelux, Oostenrijk, Frankrijk, Groot Brittannië.
 Klachten afkomstig uit overige landen worden via de eventuele lokale vertegenwoordigers van Revell afgewikkeld. Wij verzoeken U contact op te nemen met uw winkelier.

Benötigte Farben / Used Colors

Benötigte Farben
Required coloursPeintures nécessaires
Benodigde kleurenPinturas necesarias
Tintas necessáriasColori necessari
Använda färgerTarvittavat värit
Du trenger følgende fargerNødvendige farger
Необходимые краскиPotrzebne kolory
Απαιτούμενα χρώματαGerekti renkler
Potřebné barvySzükséges színek.
Potrebne barve

A

anthrazit, matt 9
anthracite grey, matt
anthracite, mat
anthracite, mate
anthracite, fosco
anthracite, opaco
antracit, matt
antrasitiitti, himmeä
koksgrå, mat
antrasilt, matt
антрацит, матовый
antracyt, matowy
ανθρακί, ματ
antraxit, mat
antracit, matná
antracit, matná
tarno siva, matt

B

aluminium, metallic 99
aluminium, metallic
aluminium, métallique
aluminium, metallic
aluminio, metalizado
aluminio, metalico
aluminio, metalico
aluminium, metallic
aluminium, metallic
aluminii, metallikiito
aluminium, metallak
aluminium, metallic
алюминиевый, металл
aluminium, metallicny
ολομίνιου, μεταλλικό
aluminium, metalik
hliniková, metaliza
aluminium, metall
aluminium, metalik

C

eisen, metallic 91
steel, metallic
coloris fer, métallique
ijzerkleurig, metallic
ferroso, metalizado
ferro, metalico
ferro, metalico
járnfárg, metallic
teräksenvärinen, metallikiito
jern, metallak
jern, metallic
стальной, металл
želazo, metaliczny
σιδηρού, μεταλλικό
demir, metalik
železná, metaliza
vas, metall
železna, metalik

D

weiß, glänzend 4
white, gloss
blanc, brillant
wit, glansend
blanco, brillante
branco, brilhante
bianco, lucente
vit, blank
valkoinen, kiiltävä
hvid, skinnende
hvit, blank
белый, блестящий
biały, błyszczący
λευκό, γυαλιστερό
beyaz, parlak
bílá, lesklá
fehér, fényes
bela, bleskajoča

50 %
grau, seidennatt 374
grey, silky-matt
gris, satiné mat
grjs, zijdemat
gris, mate seda
grá, sidenmatt
grigio, opaco seta
grá, sidenmatt
harmaa, silkkihimmeä
grá, silkematt
grá, silkematt
серый, шелковисто-матовый
szary, jedwabisto-matowy
γκρι, μεταξωτό ματ
gri, ipek mat
šedá, hedvábné matná
szürke, selyemmatt
siva, svila mat

50 %
mausgrau, matt 47
mouse grey, matt
gris souris, mat
muisgrjs, mat
gris ratón, mate
cinzento pardo, fosco
grigio topo, opaco
musgrá, matt
hiirenharmaa, himmeä
musegrá, mat
musegrá, mat
мышинно-серый, матовый
myszaty, matowy
γκρι ποτικίου, ματ
fare grisi, mat
myši šedá, matná
egérszürke, matt
mišje siva, mat

70 %
nachtsblau, glänzend 54
night blue, gloss
bleu nuit, brillant
nachtsblau, glansend
negro azulado, brillante
azul de noite, brilhante
blu notte, lucente
nattblá, blank
yönsininen, kiiltävä
natteblá, skinnende
nattblá, blank
синий ночной, блестящий
granatowy, błyszczący
μπλε νύχτας, γυαλιστερό
gece mavisi, parlak
noční modrá, lesklá
éjkek, fényes
nočno plava, bleskajoča

30 %
Ferrari-Rot, glänzend 34
Ferrari red, gloss
rouge Ferrari, brillant
Ferrari-rod, glansend
rojo Ferrari, brillante
vermelho Ferrari, brilhante
rosso Ferrari, lucente
Ferrari-rod, blank
Ferrari-punainen, kiiltävä
Ferrari-rod, skinnende
Ferrari-rod, blank
Феррари-красный, блестящий
czerwien Ferrari, błyszczący
Κόκκινο της Φιότι, γυαλιστερό
Ferrari kirmizisi, parlak
červená Ferrari, lesklá
Ferrari-piros, fényes
ferari rdeča, bleskajoča

G

silber, metallic 90
silver, metallic
argent, métallique
zilver, metallic
plata, metalizado
prata, metalico
argento, metalico
silver, metallic
hopea, metallikiito
salv, metallak
salv, metallic
серебристый, металл
srebro, metaliczny
σημί, μεταλλικό
gümüş, metalik
stříbrná, metaliza
ezüst, metall
srebrna, metalik

H

feuerrot, seidennatt 330
fiery red, silky-matt
rouge feu, satiné mat
rood helder, zijdemat
rojo fuego, mate seda
vermelho vivo, fosco sedoso
rosso fuoco, opaco seta
eldröd, sidenmatt
tulipunainen, silkkihimmeä
lidrad, silkematt
lidrad, silkematt
огненно-красный, шелк.-матовый
czerwony ognisty, jedwabisto-mat.
κόκκινο φωτιάς, μεταξωτό ματ
ateş kırmizisi, ipek mat
ohnivě červená, hedvábné matná
tűzpiros, selyemmatt
ogreni rdeča, svila mat

I

Helldgrau, matt 76
Light grey, matt
Gris clair, mat
Lichtgrjs, mat
Gris claro, mate
Cinzento-claro, mate
Grigio chiaro, opaco
Lysgrá, matt
Vaaaleanharmaa, matná
Lysgrá, mat
Lysgrá, matt
Светло-серый, матовый
Jasnoszary, matowy
γκρι ανοιχτό, ματ
Açık gri, mat
Világosszürke, matt
Světle šedivá, matná
Svetlosiva, brez leska

J

mausgrau, matt 47
mouse grey, matt
gris souris, mat
muisgrjs, mat
gris ratón, mate
cinzento pardo, fosco
grigio topo, opaco
musgrá, matt
hiirenharmaa, himmeä
musegrá, mat
musegrá, matt
мышинно-серый, матовый
myszaty, matowy
γκρι ποτικίου, ματ
fare grisi, mat
myši šedá, matná
egérszürke, matt
mišje siva, mat

K

grau, seidennatt 374
grey, silky-matt
gris, satiné mat
grjs, zijdemat
gris, mate seda
cinzento, fosco sedoso
grigio, opaco seta
grá, sidenmatt
harmaa, silkkihimmeä
grá, silkematt
grá, silkematt
серый, шелковисто-матовый
szary, jedwabisto-matowy
γκρι, μεταξωτό ματ
gri, ipek mat
šedá, hedvábné matná
szürke, selyemmatt
siva, svila mat

L

70 %
eisen, metallic 91
steel, metallic
coloris fer, métallique
ijzerkleurig, metallic
ferroso, metalizado
ferro, metalico
ferro, metalico
járnfárg, metallic
teräksenvärinen, metallikiito
jern, metallak
jern, metallic
стальной, металл
želazo, metaliczny
σιδηρού, μεταλλικό
demir, metalik
železná, metaliza
vas, metall
železna, metalik
70 %
lederbraun, matt 84
leather brown, matt
brun cuir, mat
lederbrun, mat
marón couro, mate
castanho couro, fosco
marrone couio, opaco
läderbrun, matt
nahkanruskea, himmeä
läderbrun, mat
larbrun, matt
коричневая кожа, матовый
brunatny jak skóra, matowy
καφέ δέρματος, ματ
deri kahverengi, mat
kožená hnědá, matná
bőrbarna, matt
koža rjava, mat

M

hellgrau, seidennatt 371
light grey, silky-matt
gris clair, satiné mat
lichtgrjs, zijdemat
gris claro, mate seda
cinzento claro, fosco sedoso
grigio chiaro, opaco seta
ljusgrá, sidenmatt
vaaaleanharmaa, silkkihimmeä
lysegrá, silkematt
lysegrá, silkematt
светло-серый, шелковисто-матовый
jasnoszary, jedwabisto-matowy
ανοιχτό γκρι, μεταξωτό ματ
açık gri, ipek mat
světlešedá, hedvábné matná
világosszürke, selyemmatt
svetlo siva, svila mat

N

schwarz, matt 8
black, matt
noir, mat
zwart, mat
negro, mate
preto, fosco
nero, opaco
svart, matt
musta, himmeä
sort, mat
sort, matt
черный, матовый
czarny, matowy
μαύρο, ματ
siyah, mat
černá, matná
fekete, matt
črna, mat

O

laubgrün, seidennatt 364
leaf green, silky-matt
vert feuille, satiné mat
bladgroen, zijdemat
verde follaje, mate seda
verde gaio, fosco sedoso
verde foglia, opaco seta
lövgrön, sidenmatt
lehdenvihreä, silkkihimmeä
lävgrön, silkematt
lävgrön, silkematt
zielono-zielony, шелк.-матовый
zielony liściasty, jedwabisto-matowy
πράσινο φυλλωμάτων, μεταξωτό ματ
yaprak yeşili, ipek mat
zelená jako listi, hedvábné matná
lombzöld, selyemmatt
list zelena, svila mat



Nicht benötigte Teile
Parts not used
Pièces non utilisées
Niet benodigde onderdelen
Piezas no necesarias
Peças não utilizadas
Parti non usate
Inte användbara delar
Tarpeettomat osat
Ikke nødvendige dele
Delar som ikke er nødvendige
Неиспользуемые детали
Elementy niepotrzebne
μη χρειαζούμενα εξαρτήματα
Gereksiz parçalar
Nepotřebné díly
fel nem használt alkatrészek
Nepotrebni deli

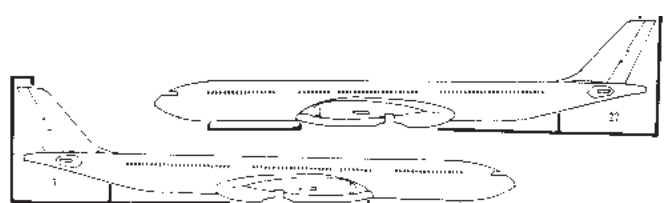
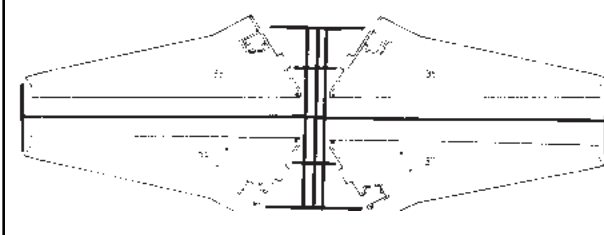
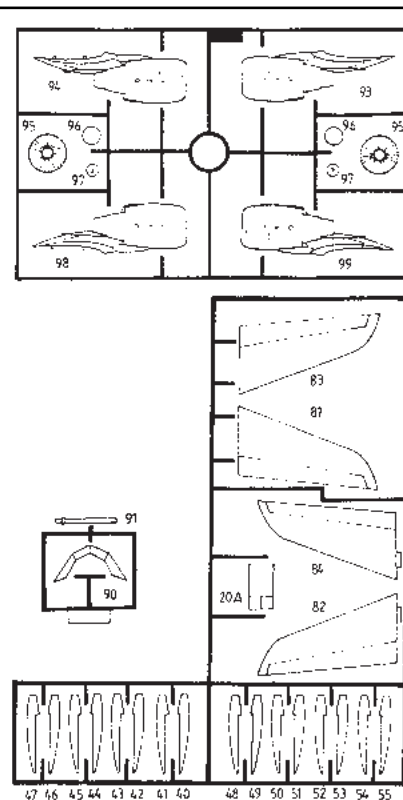
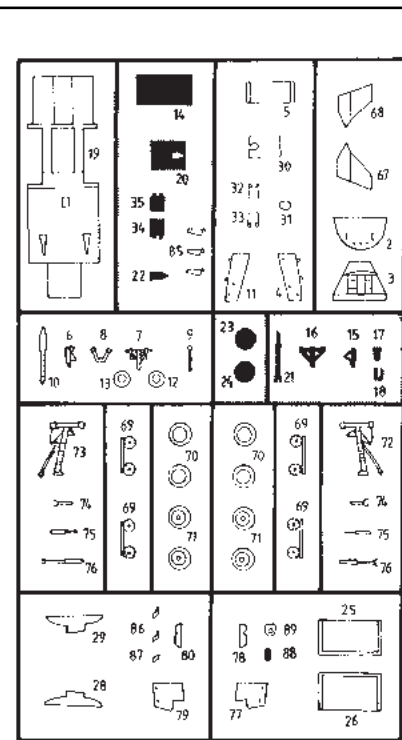

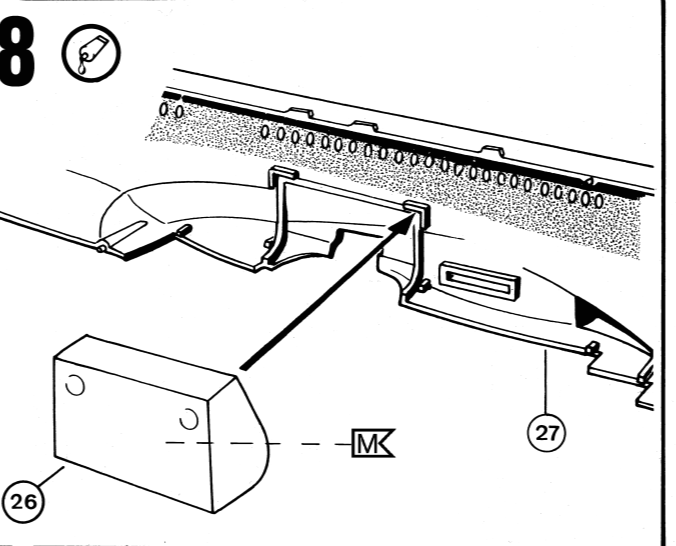
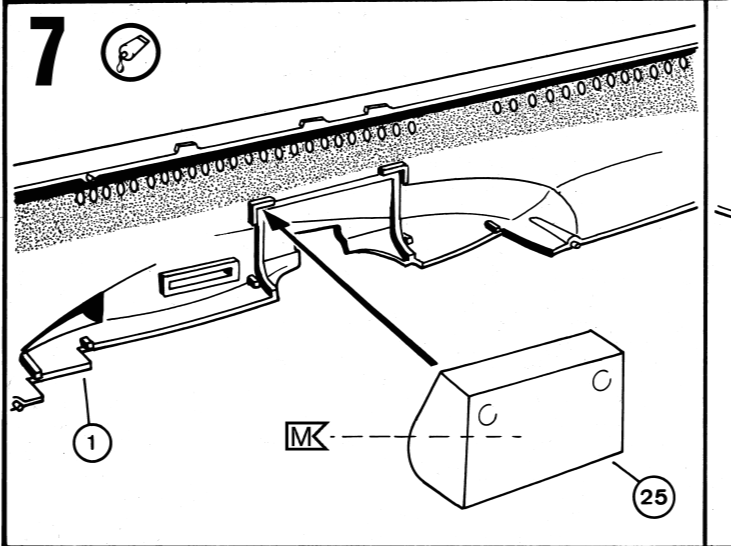
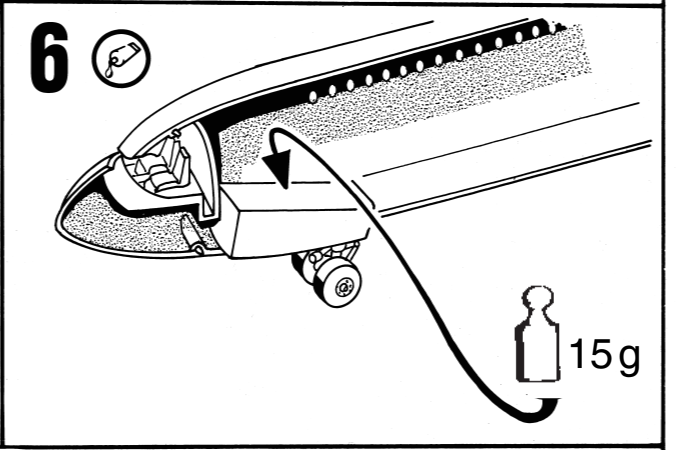
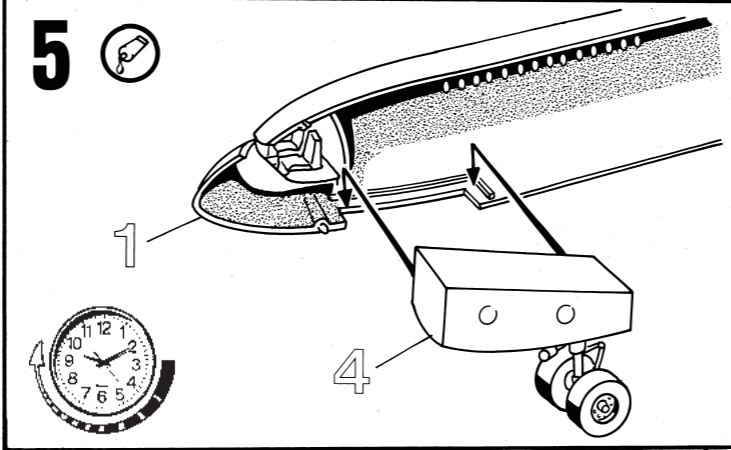
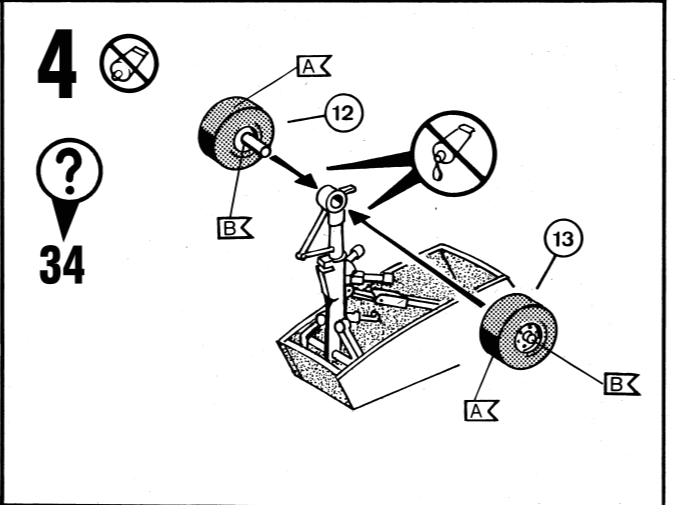
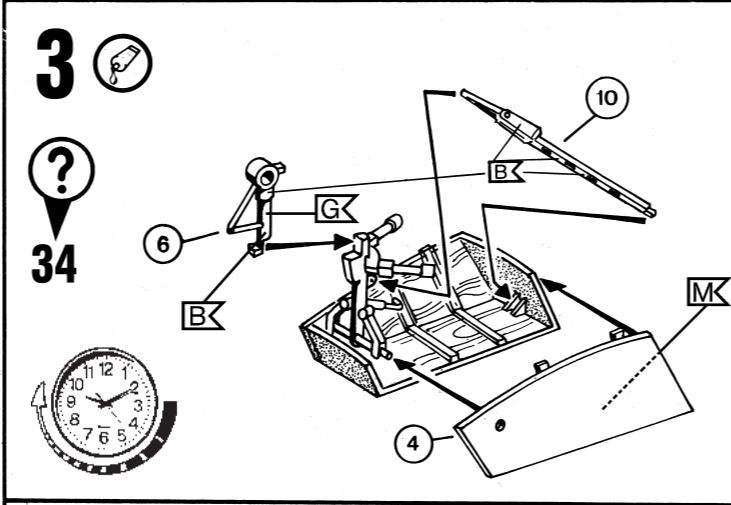
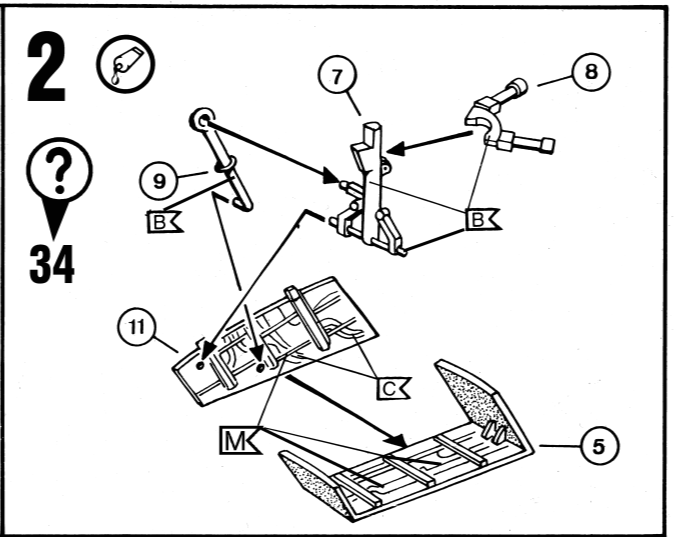
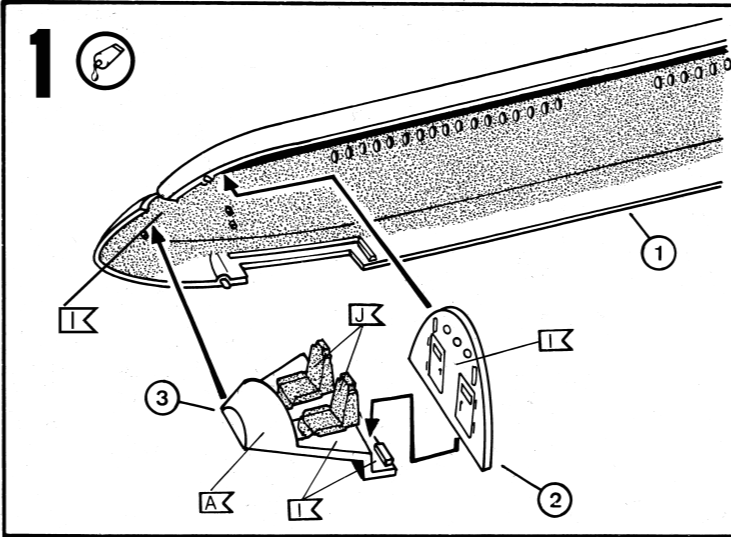

9

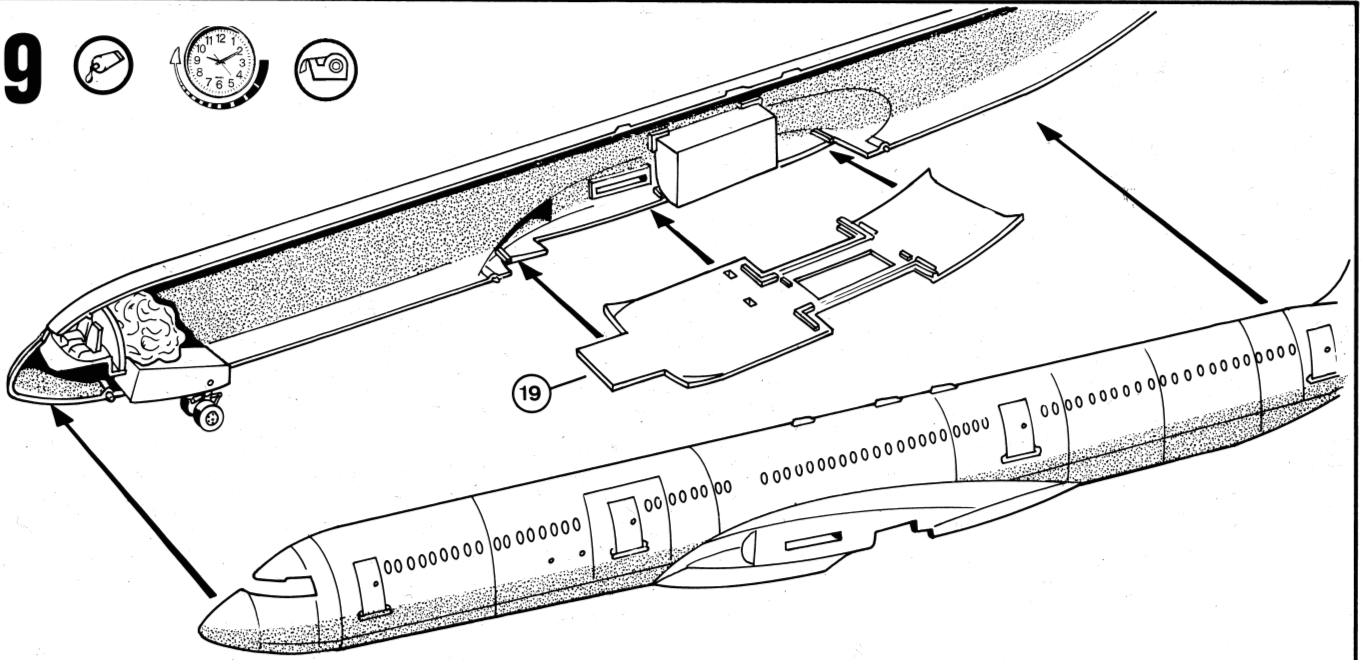

10

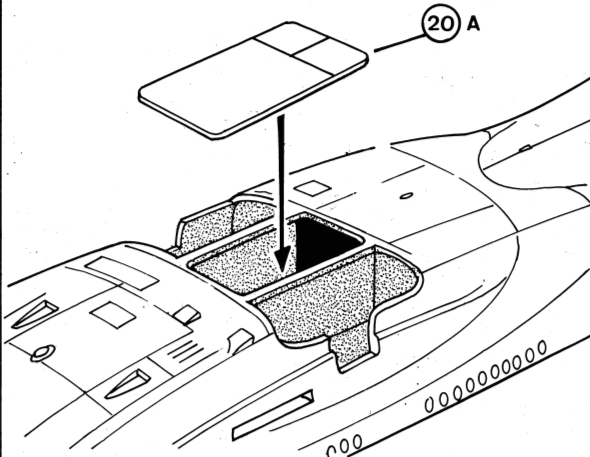

11

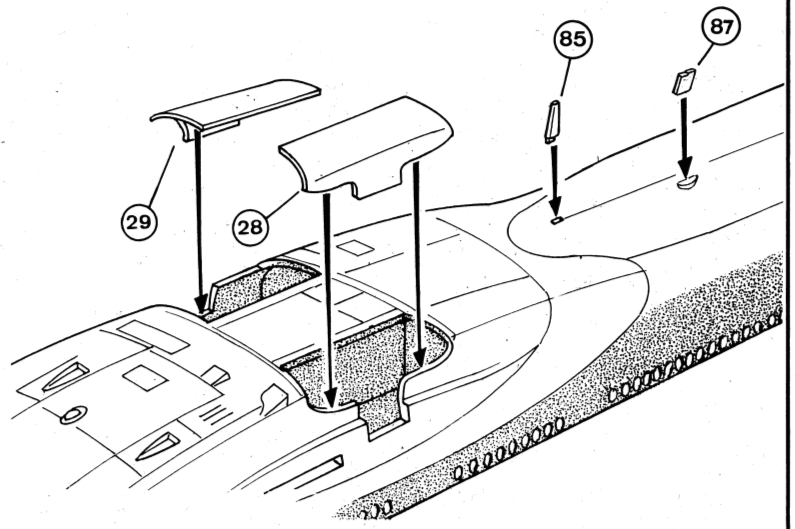

12



34

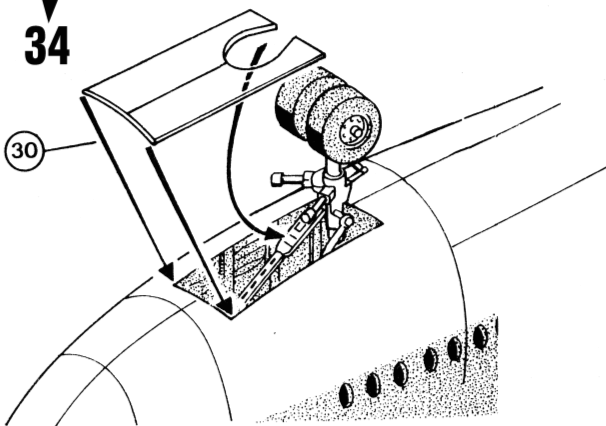

13



34

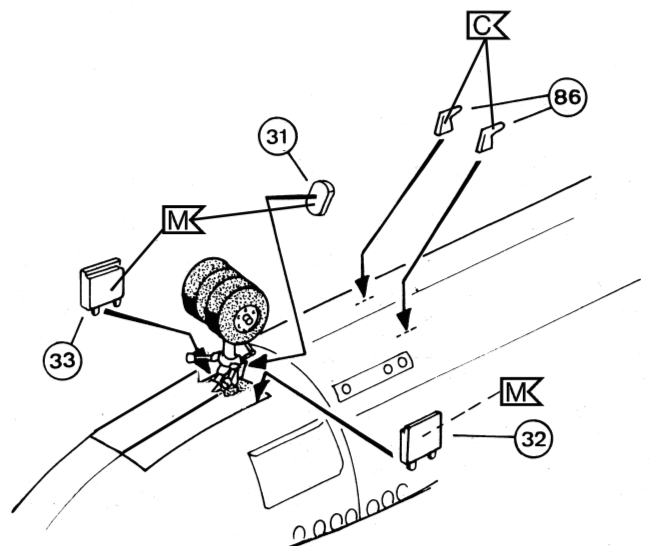

14

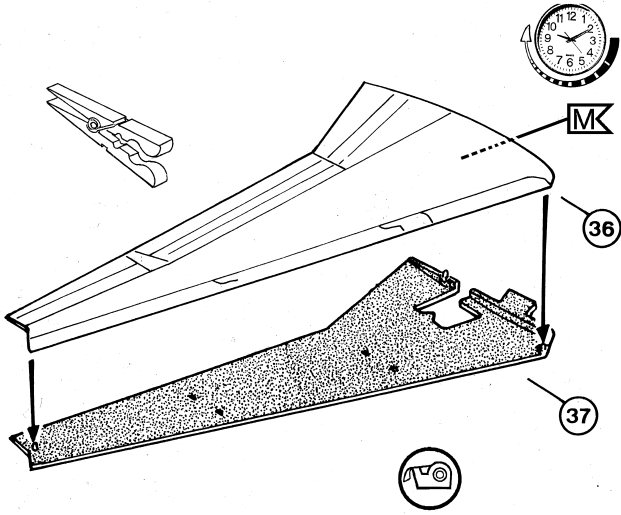

15

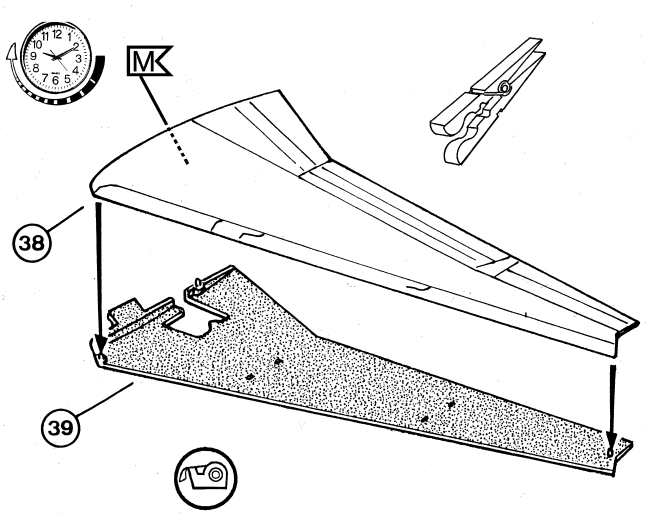

16

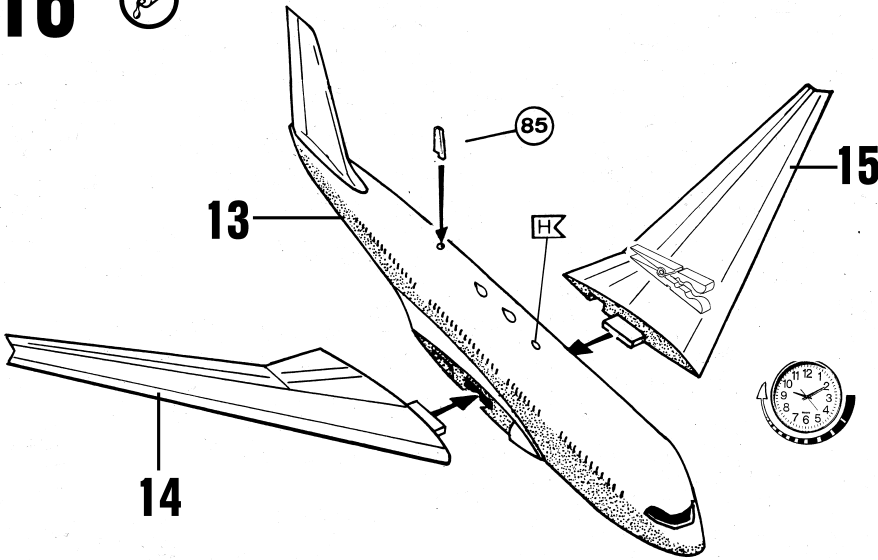

17

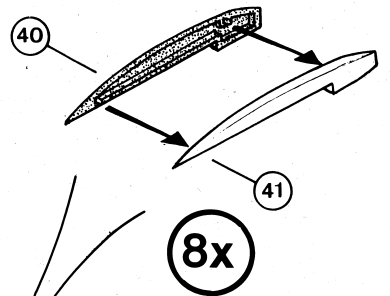

18

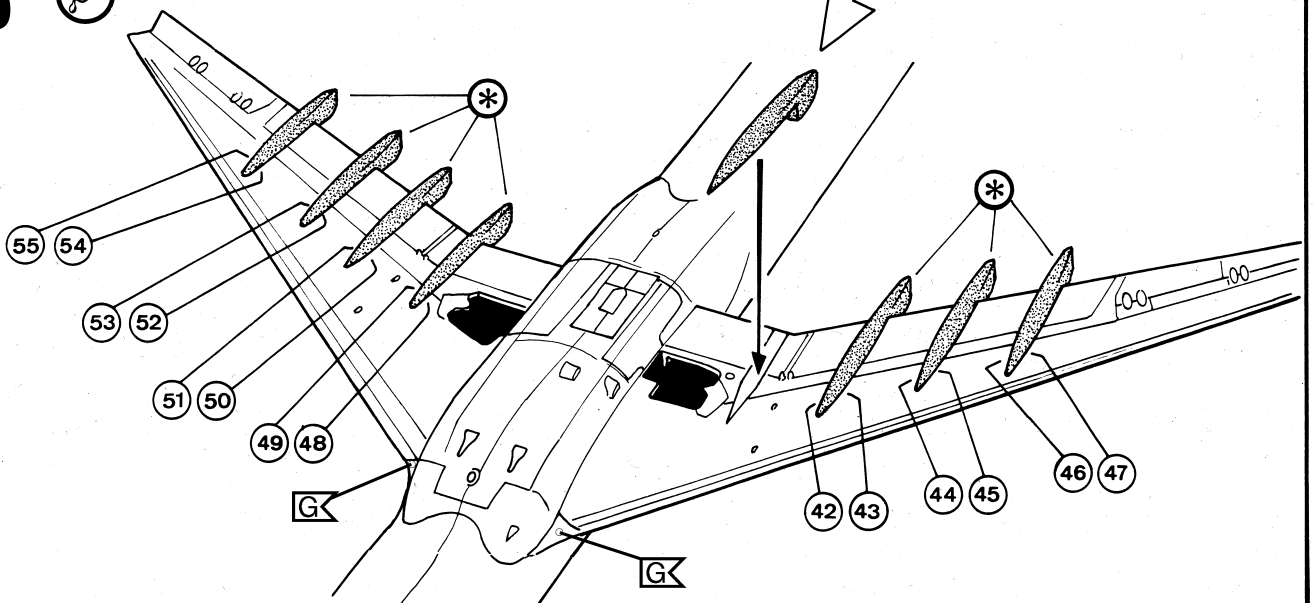

19

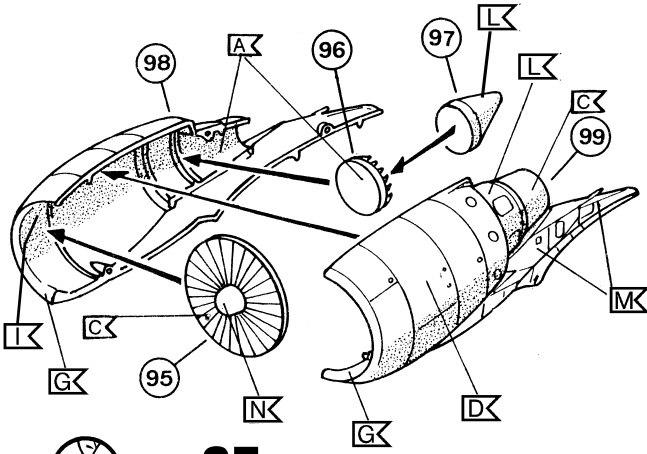

→ **35a**

20

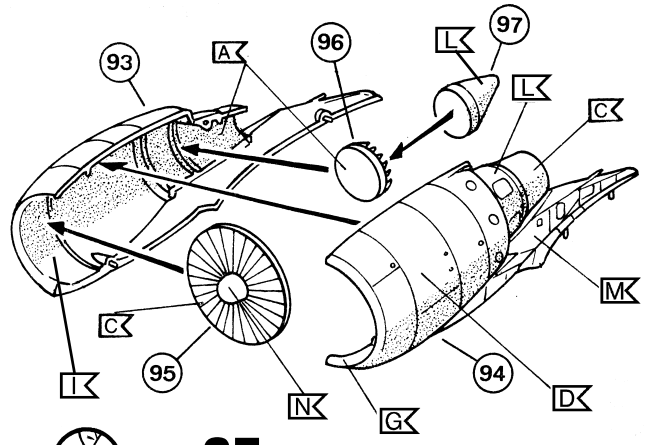

→ **35a**

21

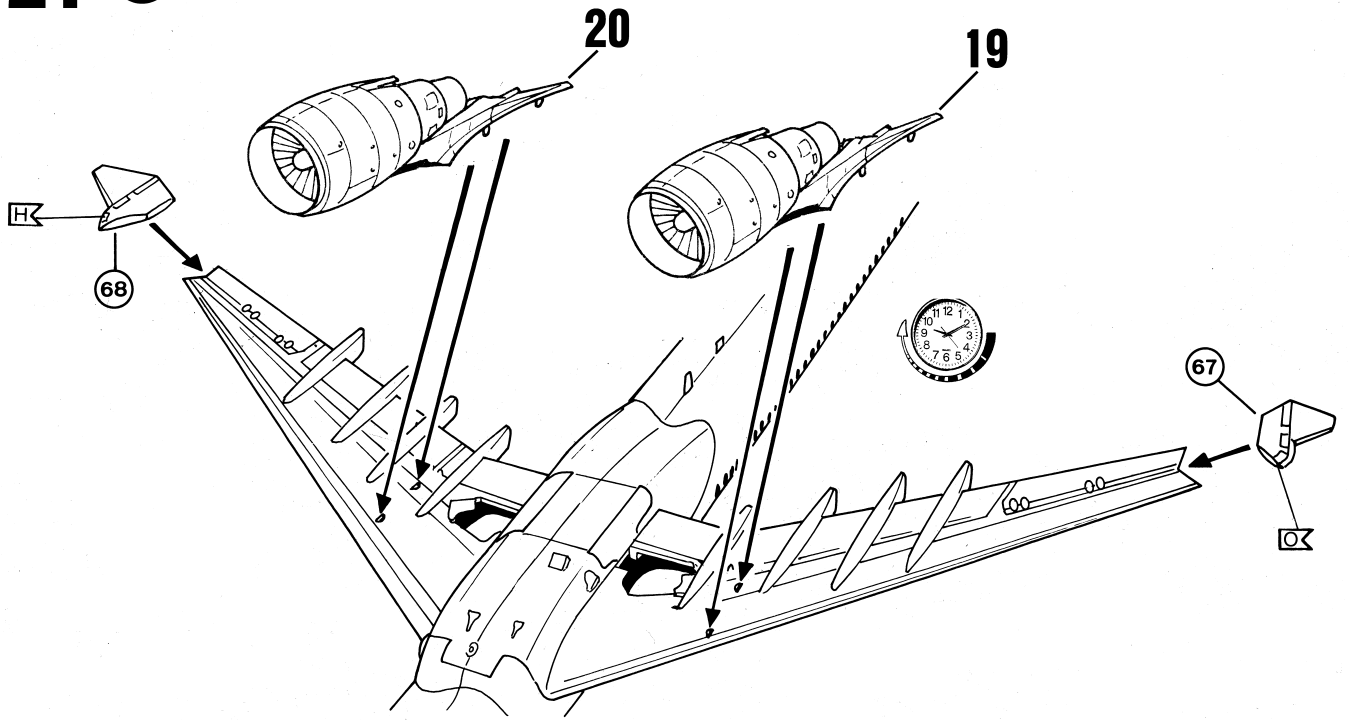

22



→ **34**

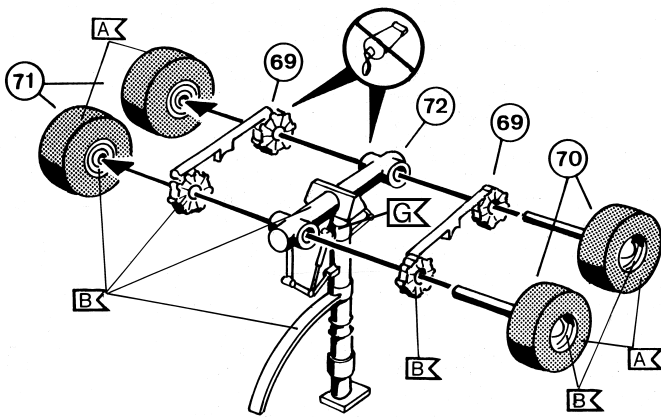

23



→ **34**

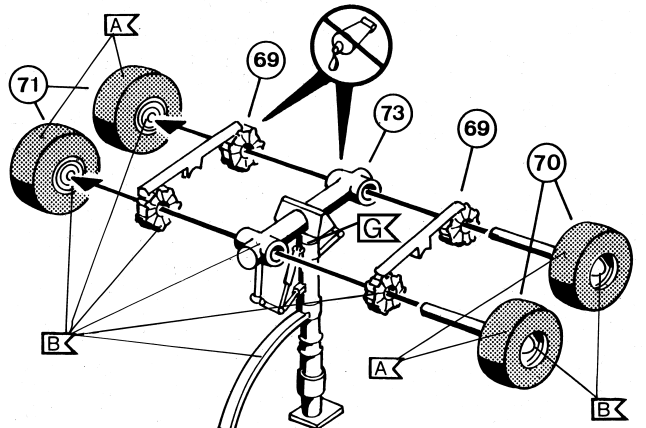

24

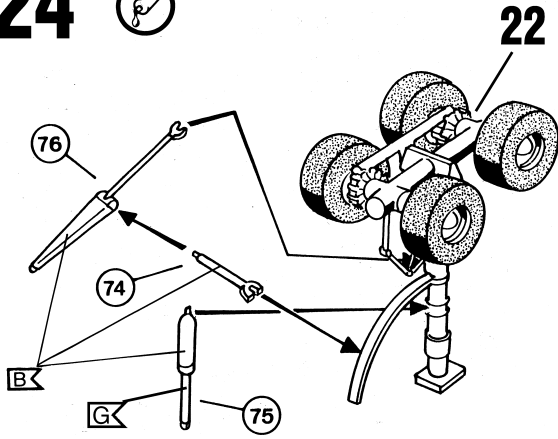

25

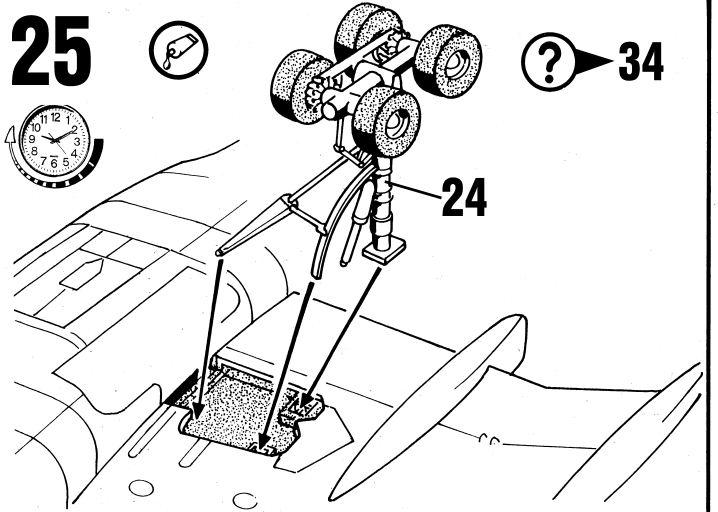

26

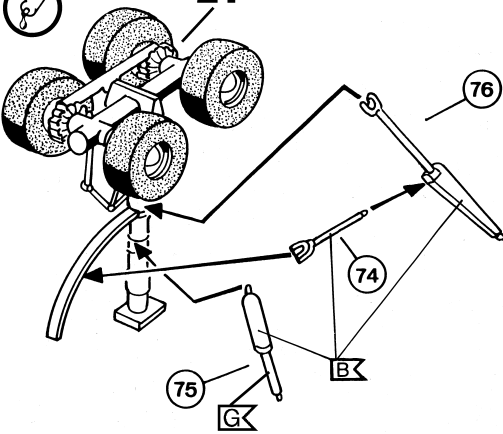

27

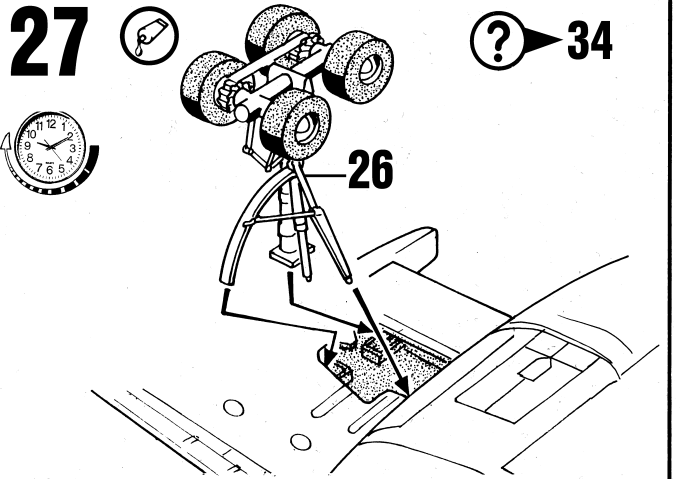

28

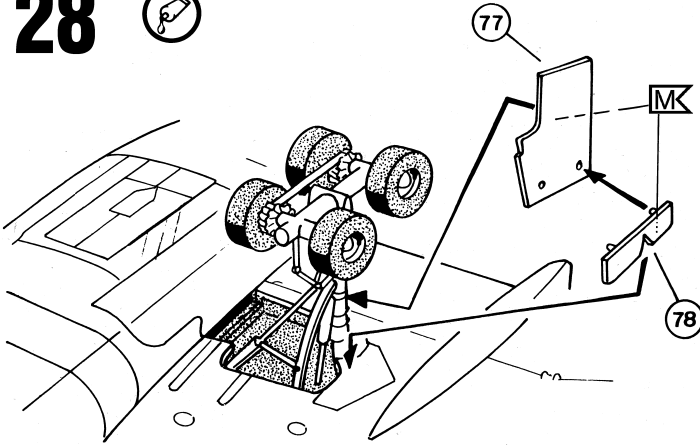

29

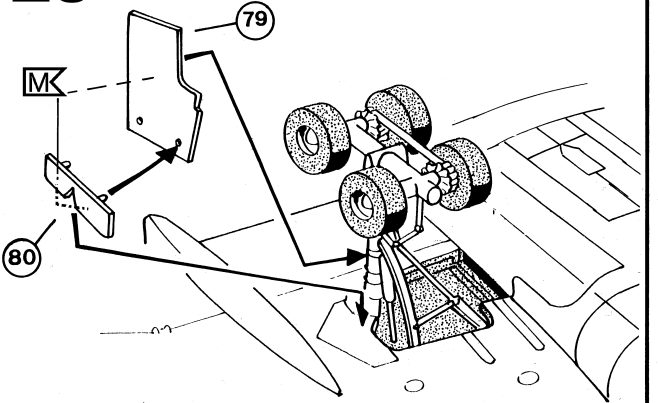

30

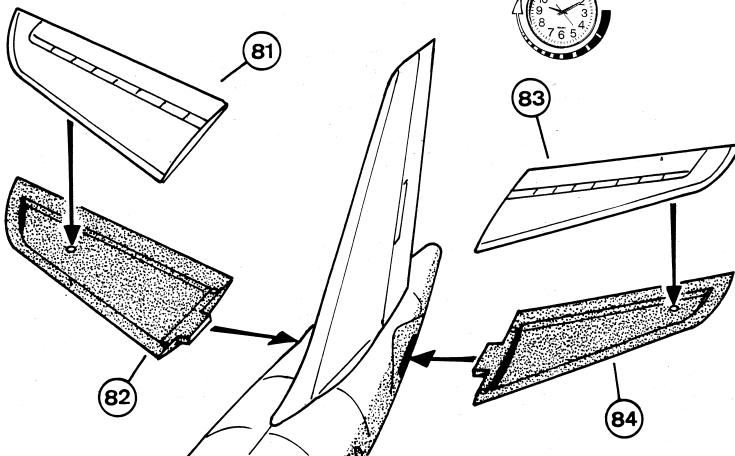

31

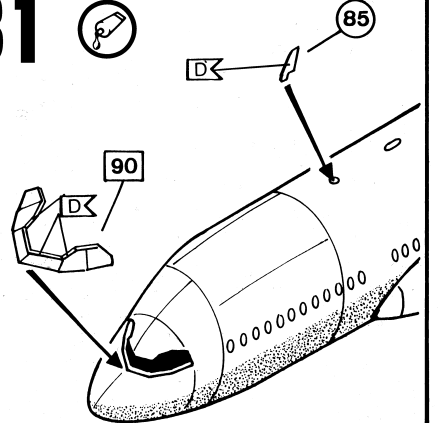

32

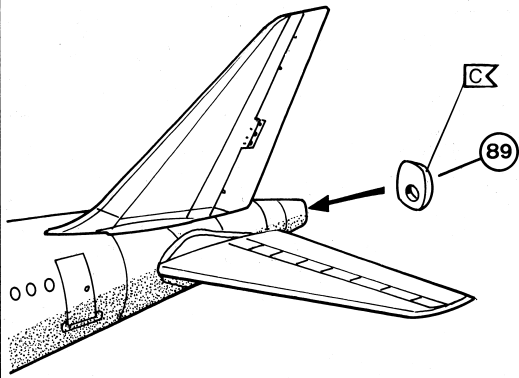

34

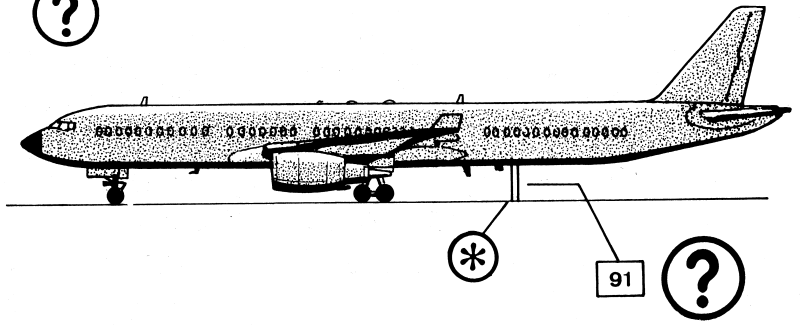

35

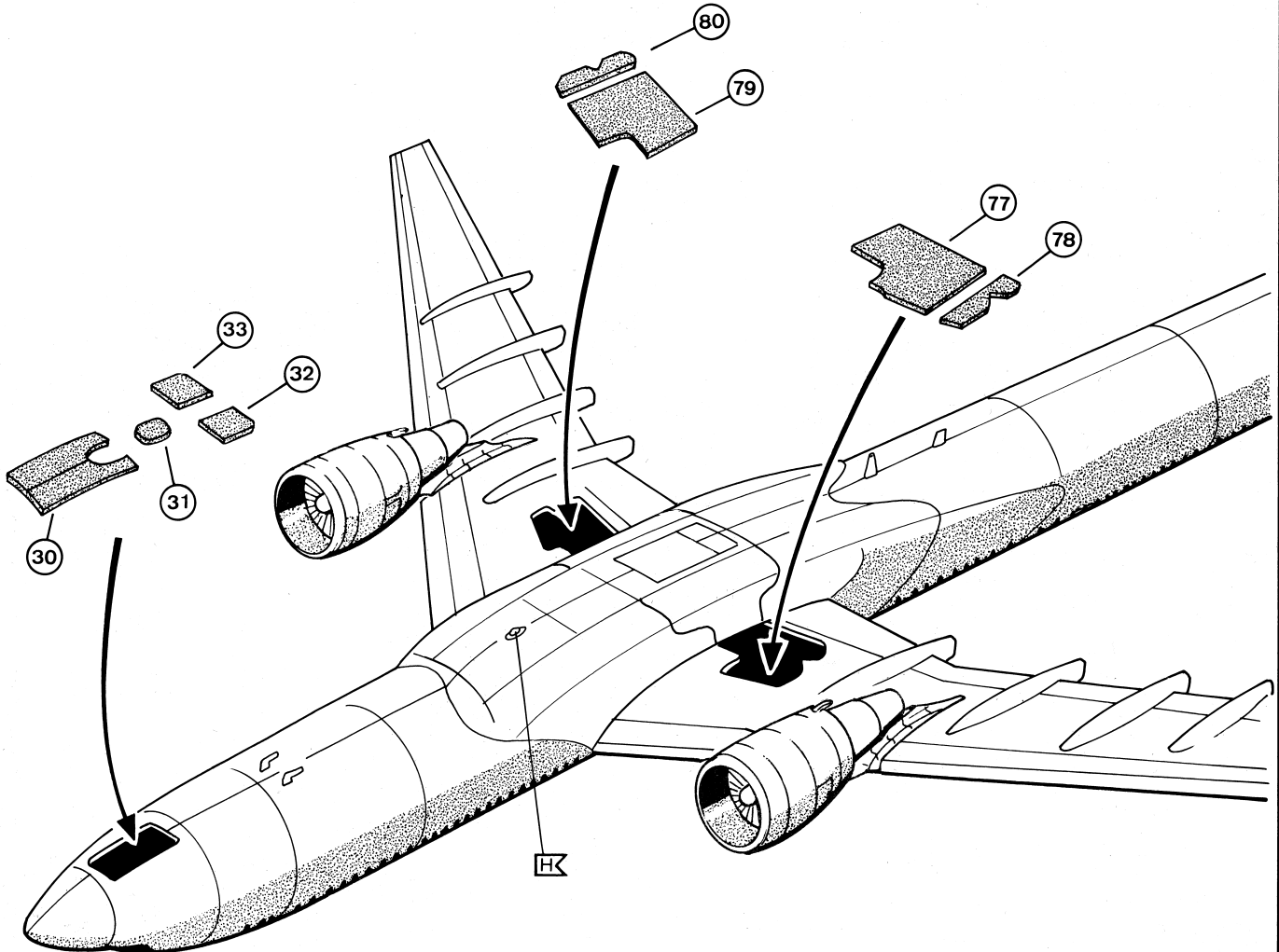
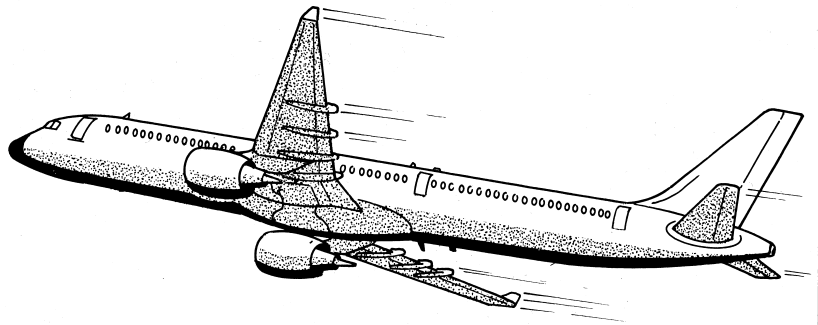

35a



Airbus A330-300 Thai Airways

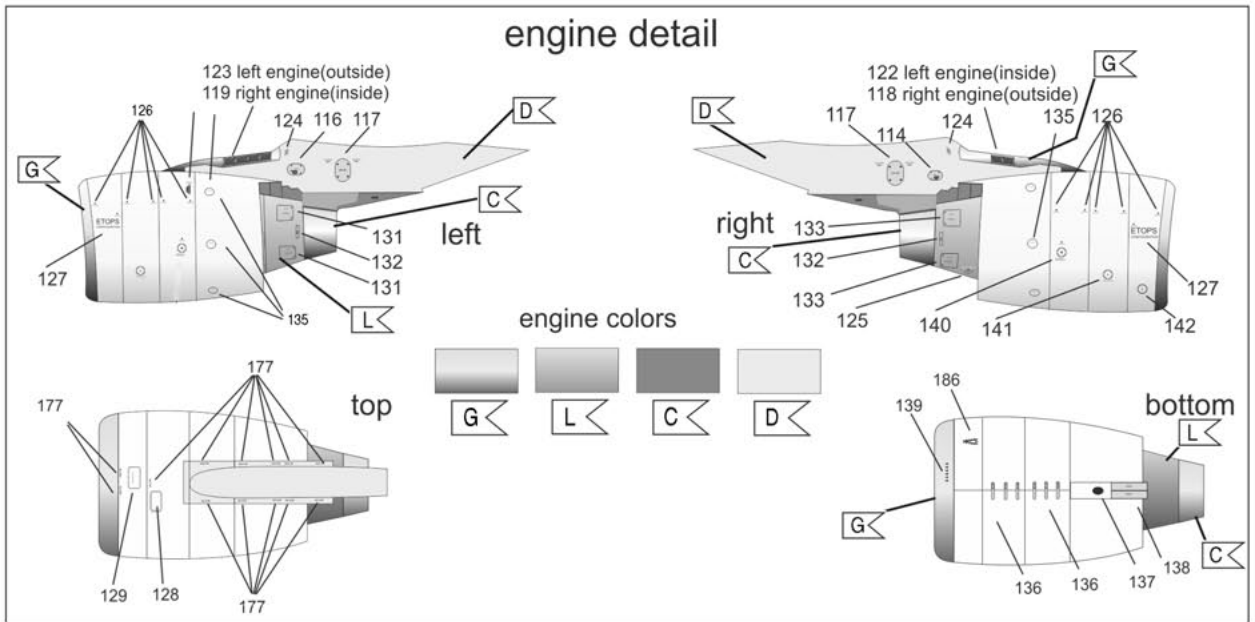
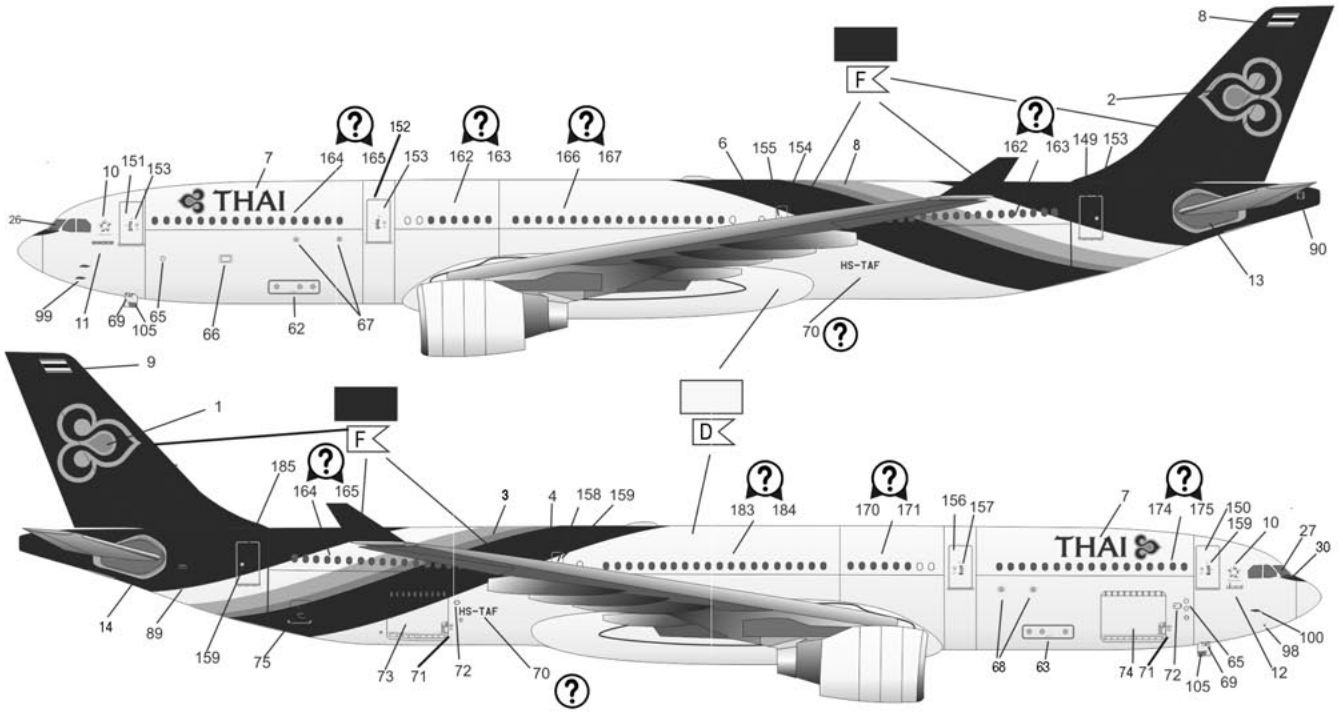

11

12

- HS-TEA Manom มโนรมย์
- HS-TEB Sri Sakhon ศรีสาคร
- HS-TEC Bang Rajan บางระจัน
- HS-TED Donchedi ดอนเจดีย์
- HS-TEE Kusuman กุสุมาลัย
- HS-TEF Song Dao ส่องดาว
- HS-TEG Lam Plai Mat ลำปลายมาศ
- HS-TEH Sai Buri สายบุรี
- HS-TEJ Sudawadi สดาวดี
- HS-TEK Srichulalak ศรีจุฬาลักษณ์

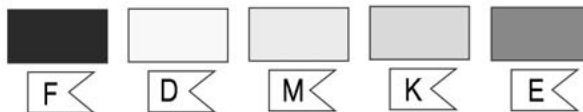

35b

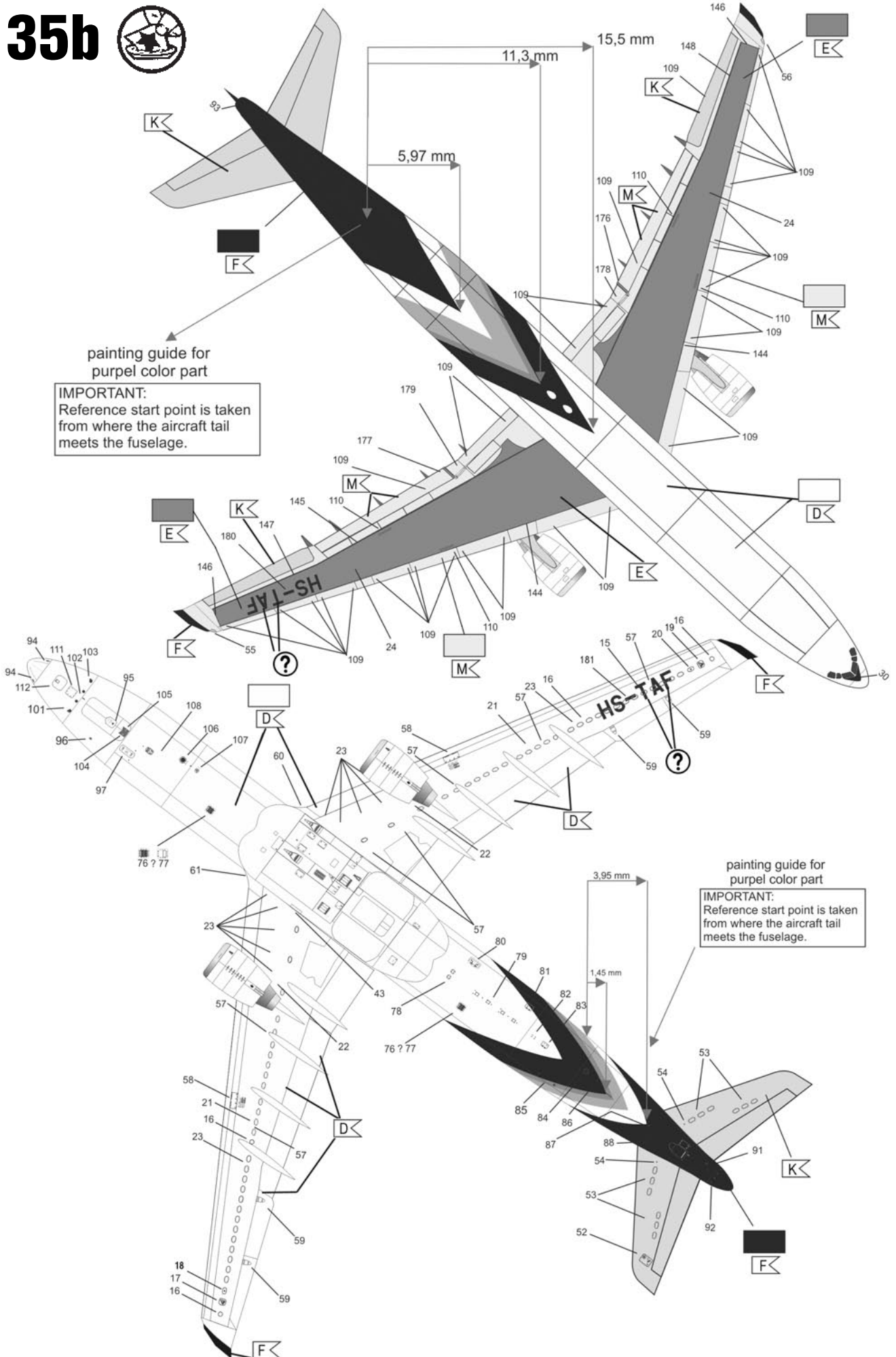

painting guide for purpel color part

IMPORTANT:
Reference start point is taken from where the aircraft tail meets the fuselage.

painting guide for purpel color part

IMPORTANT:
Reference start point is taken from where the aircraft tail meets the fuselage.