

FUNCTIONS

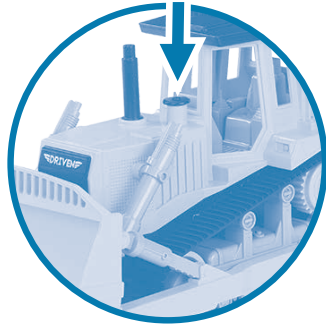

Rake pivots up and down



Press button on hood to hear engine sound



Shovel pivots up and down

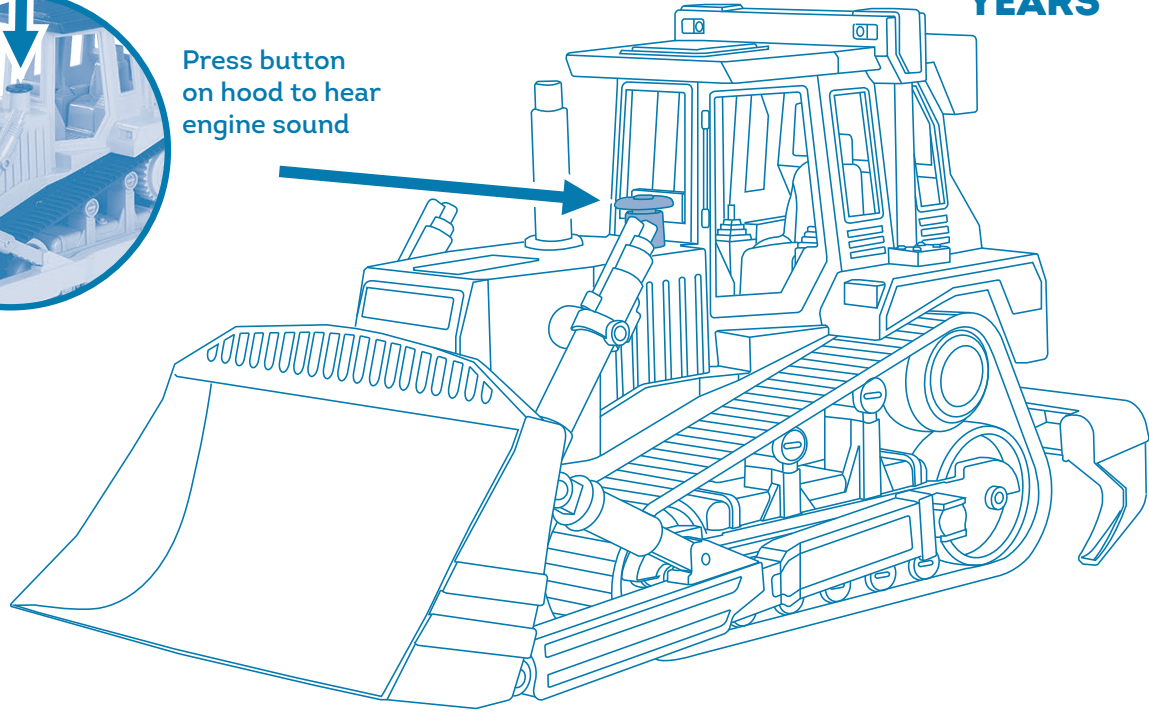

- Prolonged exposure to sunlight may damage rubber components.
- Excessive sand, dirt and/or water may cause the toy to malfunction.
- Rough or inappropriate usage may result in permanent damage to the toy.

Chassis Batteries

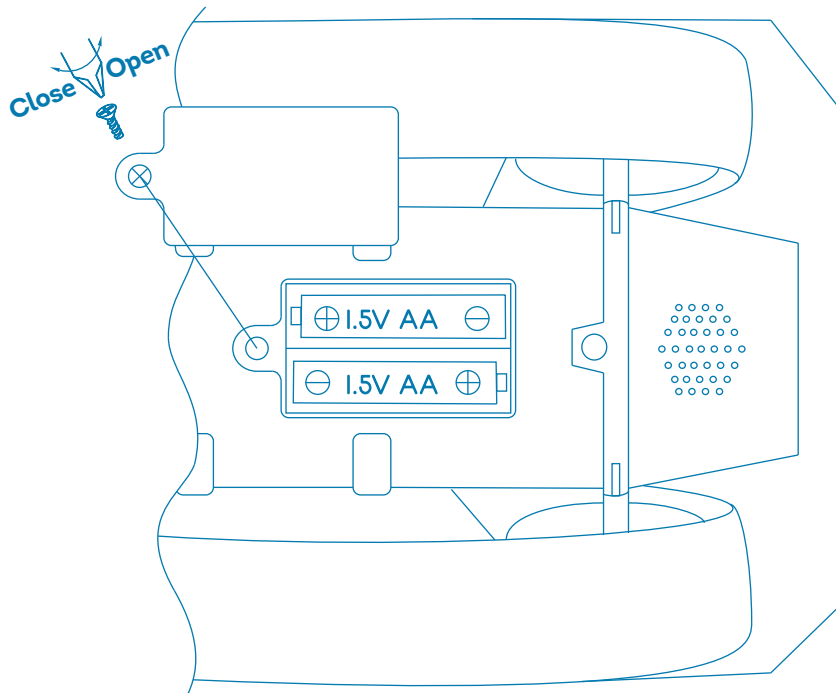

REPLACING BATTERIES

2 x AA(1.5V) BATTERIES INCLUDED

- Do not mix old and new batteries.
- Do not mix alkaline, standard(carbon-zinc), or rechargeable (nickel-cadmium) batteries.
- Dead batteries? Check out earth911.com to quickly find the recycling center nearest you.

This device complies with Part 15 of the FCC Rules. Operation is subject to the following two conditions: (1) this device may not cause harmful interference, and (2) this device must accept any interference received, including interference that may cause undesired operation.

Caution: changes or modifications not expressly approved by the party responsible for compliance could void the user's authority to operate the equipment.

NOTE: This equipment has been tested and found to comply with the limits for a Class B digital device, pursuant to Part 15 of the FCC Rules. These limits are designed to provide reasonable protection against harmful interference in a residential installation. This equipment generates, uses and can radiate radio frequency energy and, if not installed and used in accordance with the instructions, may cause harmful interference to radio communications. However, there is no guarantee that interference will not occur in a particular installation. If this equipment does cause harmful interference to radio or television reception, which can be determined by turning the equipment off and on, the user is encouraged to try to correct the interference by one or more of the following measures:

- Reorient or relocate the receiving antenna.
- Increase the separation between the equipment and receiver.
- Connect the equipment into an outlet on a circuit different from that to which the receiver is connected.
- Consult the dealer or an experienced radio/TV technician for help.

WH1004



WARNING:

CHOKING HAZARD - Small parts.
Not for children under 3 years.