

# ACADEMY

HOBBY MODEL KITS

## 12105



**F-16I 수파**  
1/32nd Scale

# F-16I SUFA



		GS1 CREOS		LIFE COLOR	HUMBROL	TESTOR/MODEL MASTER		
		AGUEOUS HOBBY COLOR	Mr. COLOR			ENAMEL	ACRYL	
1	WHITE	H<1>	1	LC51	22	1745	4696	유광 흰색
2	BLACK	H<2>	2	LC52	21	57211	4695	유광 검정색
3	RED	H<3>	3	LC5	19	1103		유광 빨강색
4	YELLOW		329	UA140	154	1708	4721	유광 노랑색
5	BRIGHT GREEN	H<26>	66	LC11	2	52715		브라이트 그린
6	SILVER	H<8>	8	LC74	11	1790	4678	은색
7	GUN METAL				53	1405	4681	건 메탈
8	CLEAR RED	H<90>	47		1321		4630	클리어 레드
9	CLEAR ORANGE	H<92>	49				4625	클리어 오렌지
10	CLEAR BLUE	H<93>	50				4658	클리어 블루
11	FLAT WHITE	H<11>	62	LC01	34	1768	4769	무광 흰색
12	FLAT BLACK	H<12>	33	LC02	33	1749	4768	무광 검정색
13	FLESH	H<44>	51	LC41	61		4678	살구색
14	METALLIC GRAY	H<28>	61	LC76	12533	1795	4681	메탈릭 그레이
15	OLIVE GREEN		120	UA030	123	2081	4790	올리브 그린
16	KHAKI	H<81>	55	UA039	72	1792		카키색
17	SANDY BROWN	H<313>		121				샌디 옐로우
18	BROWN	H<310>	310	UA051	118		4709	브라운
19	BUFF	H<313>		121				버프
20	RED BROWN	H<47>	41	LC67	160	1701	4707	레드 브라운
21	OLIVE DRAB		304	UA003	155	1711	4728	올리브 드랍
22	KHAKI GREEN	H<80>	54					카키 그린
23	LIGHT GREEN	H<74>	26	UA095	23			라이트 그린
24	BURNT IRON	H<76>	61	LC74	56	1796	4676	흑철색
25	DARK GHOST GRAY/ FS 36320	H<307>	307	UA027	128	1741	4761	다크 고스트 그레이
26	LIGHT GHOST GRAY/ FS 36320	H<308>	308	UA062	127	1728	4762	라이트 고스트 그레이
27	GUNSHIP GRAY/ FS 36118	H<305>	305	UA022	125	1723	4752	건쉽 그레이
28	DARK GULL GRAY/ FS 36231	H<317>	317	UA033	140		4755	다크 걸 그레이
29	MEDIUM GRAY/ FS 36270	H<306>	306	UA028	126	1725	4757	미디엄 그레이
30	LIGHT BLUE/ FS 15102	H<323>	323	UA037	47	2030		라이트 블루
31	CLEAR GREEN	H<94>	138				4668	클리어 그린

**PE Necessary tool for etching attachment**  
에칭 부착에 필요한 도구

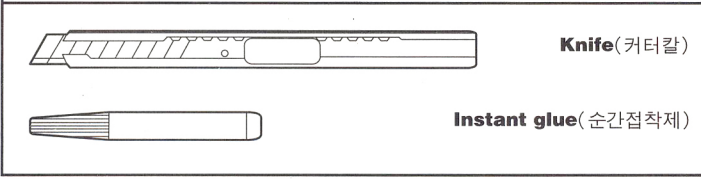

**<READ THIS BEFORE YOU BEGIN>**

- Study the instructions before assembling. - Check the fit of each piece before cementing into place.
- Do not use too much cement to join parts. - Never use cement or paint near open flame.
- Open a window or make area well ventilated when cement or paint is in use.
- Tear up and throw away the empty plastic bags to avoid danger of suffocation for little children.

**<ALLGEMEINE HINWEISE>**

- Die Anordnung der Bauteile ist aus den Zeichnungen der Anleitung ersichtlich.
- Die Teile vor dem Verkleben ungeleimt zusammenhalten, um ihren paßsitz zu prüfen.
- Klebstoff nicht zu dick auftragen. - Klebstoff und Farben niemals in der Nähe einer Flamme verwenden.
- Während der Bemalung mit Spritzpistole oder Pinsel für frische Luftzufuhr, z.B. öffnen des Fensters, sorgen.
- Bausatz von kleinen Kindern fernhalten. Verhüten Sie, daß Kinder irgendwelche Bauteile in den Mund nehmen oder Plastiktüten über den Kopf ziehen.

**■ 조립하기 전에**

- 부품을 조립하기 전에 설명서를 잘 읽어본 후 조립한다. - 부품을 자를 때에는 칼이나 니퍼로 깨끗이 잘라준다. - 접착제를 사용할 곳과 사용하지 않는 곳에 주의하고 너무 많이 바르지 않도록 한다.
- 접착하기 전에 부품을 맞추어 확인한 후 조립한다. - 에나멜 페인트나 접착제를 사용할 때는 창문을 열어 환기를 시키고 회기를 멀리한다. - 사용 후 남은 부품은 어린 아이들의 손에 닿지 않도록 잘 처리한다.

**<LISEZ CE QUI SUIT AVANT DE COMMENCER LE MONTAGE>**

- Etudier les schémas d'assemblage. - Contrôler que chaque pièce soit bien conforme avant de la coller à sa place.
- N'utilisez pas trop de colle pour réunir les pièces. - Ne jamais manipuler la colle ou peinture à proximité d'une flamme.
- Aérer soigneusement la pièce et vous peignez(ouvrir la fenêtre).
- Après avoir sorti les pièces du sac en plastique, déchirer le sac afin d'éviter que les enfants ne le mettent sur la tête et ne s'étouffent.

**<組み立てる前に>**

- 組み立てる前に説明書をお読み下さい。 - 部品をランナーから切りはずす時は模型用ニッパーとカッターを使用します。
- 接着剤を少し少なめに使うことがきれいに仕上げるコツです。 - 接着する前に部品を合わせて確かめます。
- 接着剤や塗料を使用する時はときどき窓を開けて換気をお願いします。
- 組み立て後の部品やビニール袋は小さな子供の手の届かない安全な所に保管して下さい。



점착한다.  
Cement parts  
Coller  
Kleben  
Pegar  
Incollare  
Colar  
Kleben



점착하지 않는다.  
Do not cement  
Ne pas coller  
Nicht kleben  
No pegar  
Non incollare  
Nao colar  
Niet kleven



수반을 조립한다.  
Repeat operation  
Répéter l'opération  
Vorgang wiederholen  
Repitir la operacion  
Ripetere  
Repitir a operacao  
Herhalen



전사지를 붙인다.  
Decals  
Dècalcomanies  
Abziehbild



무게추를 넣는다.  
Add weight  
Lester  
Gewicht



구멍이나 홈을 매워준다.  
Use filler  
Mastiquer  
Schleifen



잘라낸다.  
Cut away  
Couper  
Schneiden  
Cortar  
Tagliare  
Cortar  
Snijden



선택한다.  
Optional parts  
Choix  
Auswahlmöglichkeit  
Eleccion  
Scelta  
Opcao  
Keuze



반대측도 조립한다.  
Repeat for opposite side  
Répétition de la page  
Wiederholung für gegenüberliegende Seite



구멍을 뚫어준다.  
Make hole  
Faire un trou  
Offnen



주의한다.  
Be careful  
Faire attention  
Hier Vorsicht



색칠 및 전사지 붙이기 번호  
Painting scheme number  
Numeros de la liste de peintures  
Lackierschemanummer

1

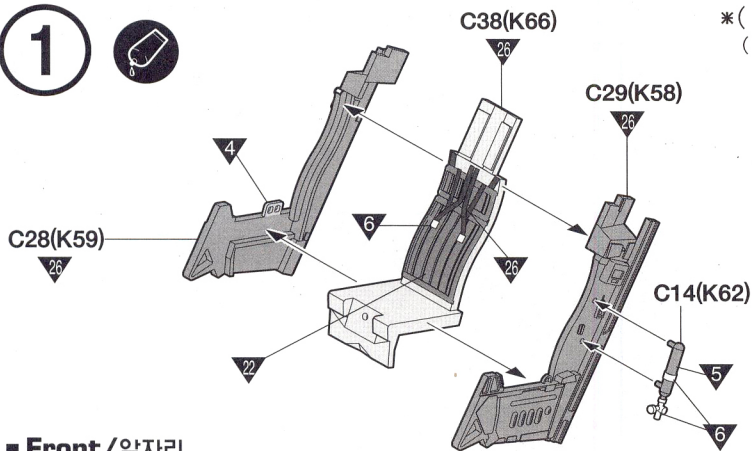

■ Front/앞자리

\* ( ) is opposite number.  
( )는 반대측 번호입니다.

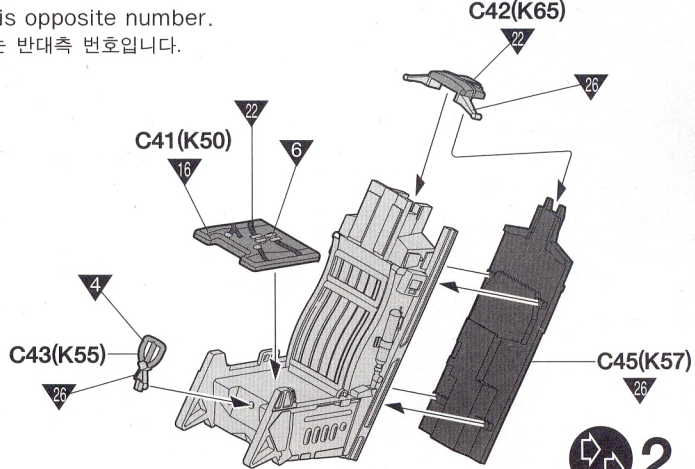

■ Seat/의자

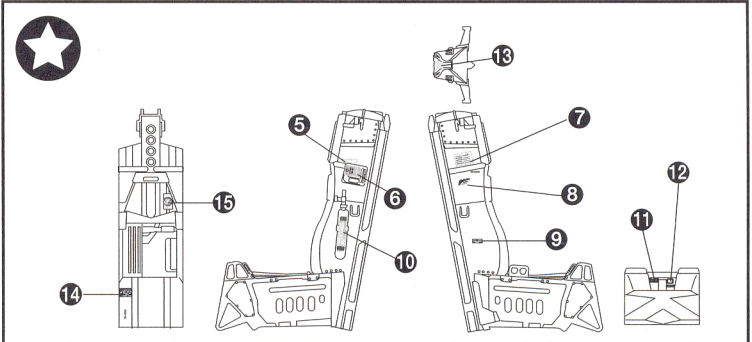

■ Instrument panel/계기판

■ Rear/뒷자리

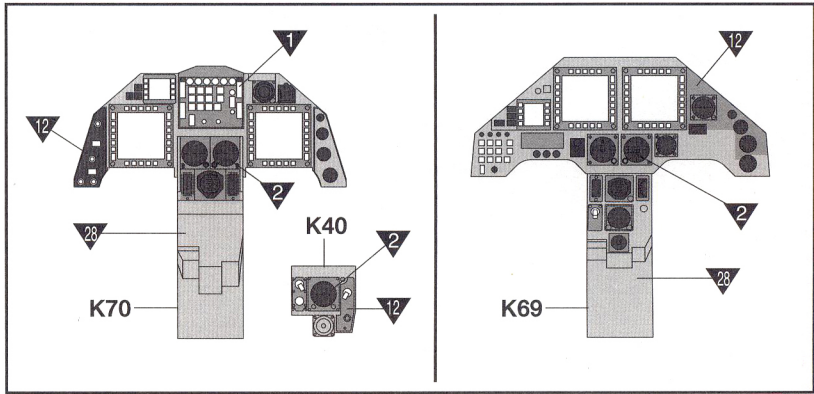
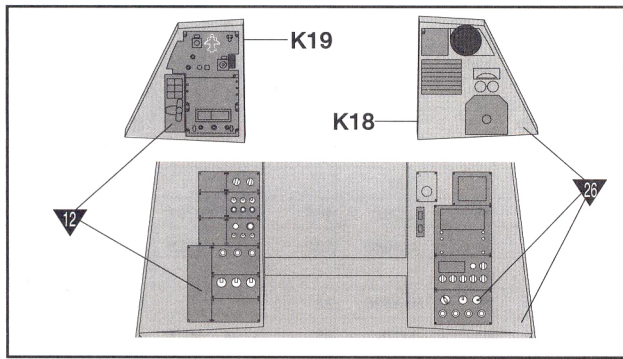

2

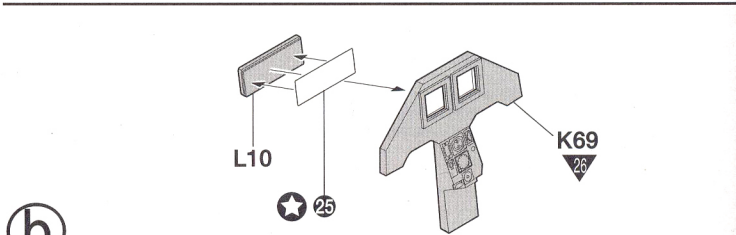
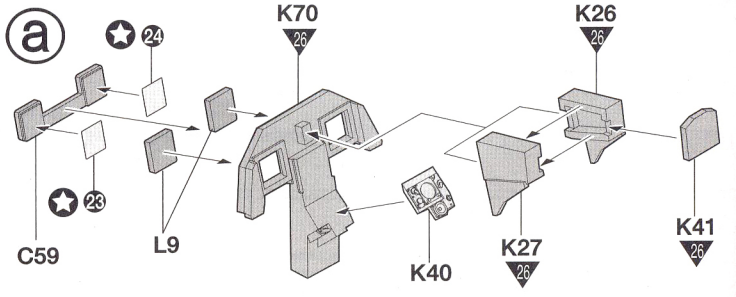
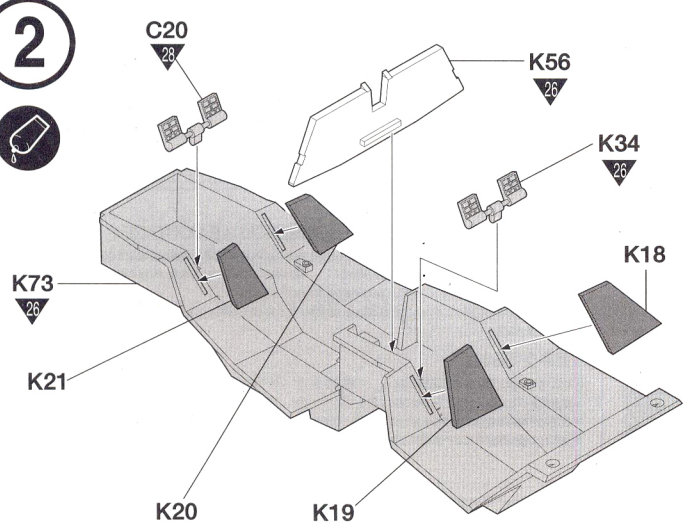

**3**

**Open**  
캐노피 열린상태

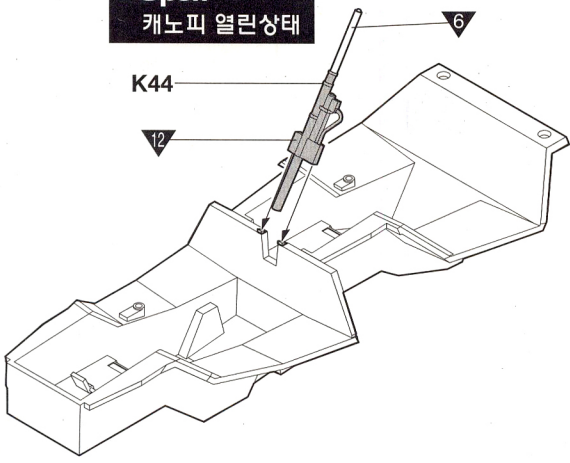
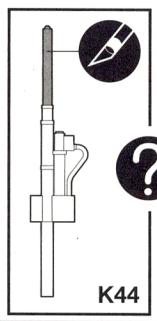

**Closed**  
캐노피 닫힌상태

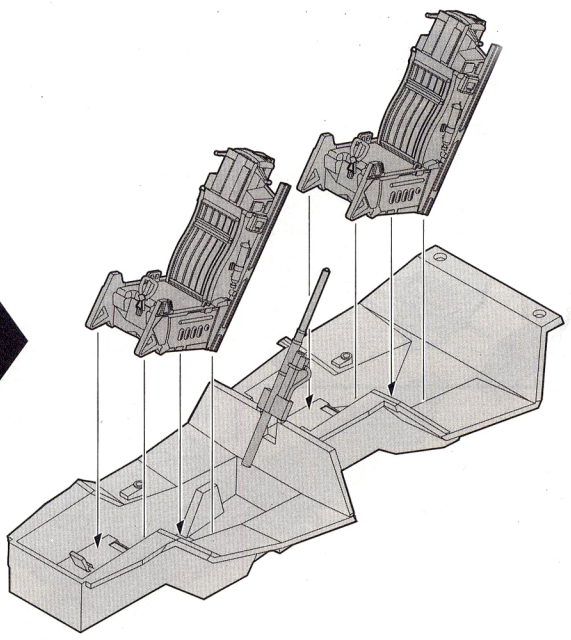

**4**

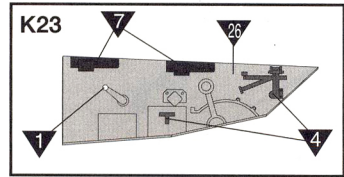

\*( ) is opposite number.  
( )는 반대측 번호입니다.

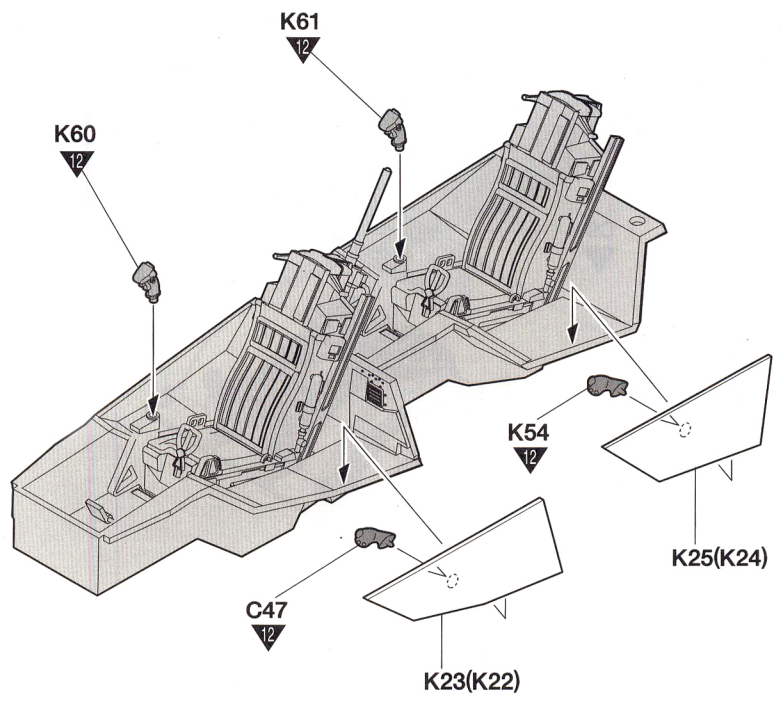
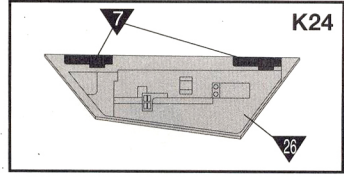
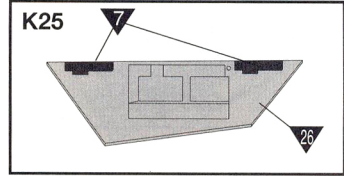
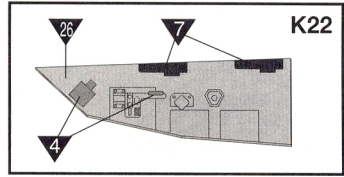

**5**

※ Attach **1** first.  
1번부터 조립합니다.

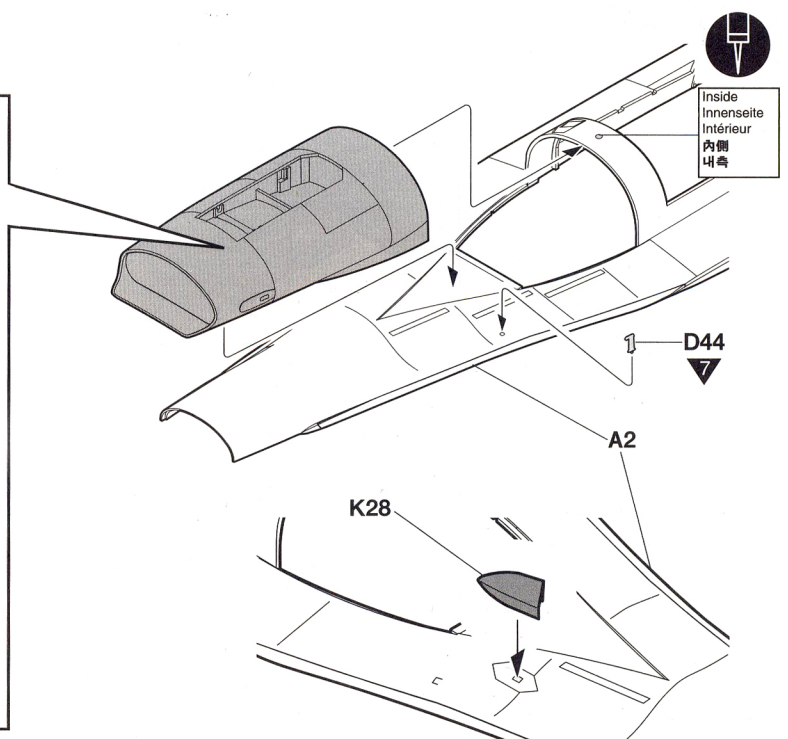
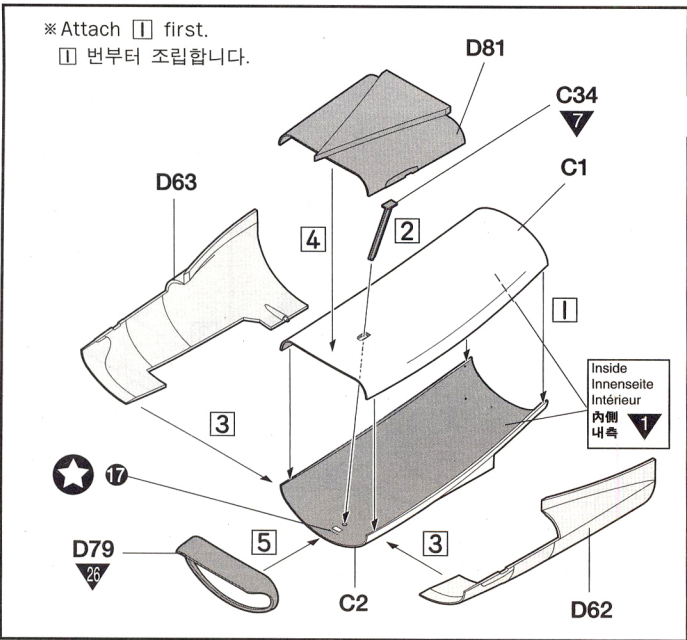

6

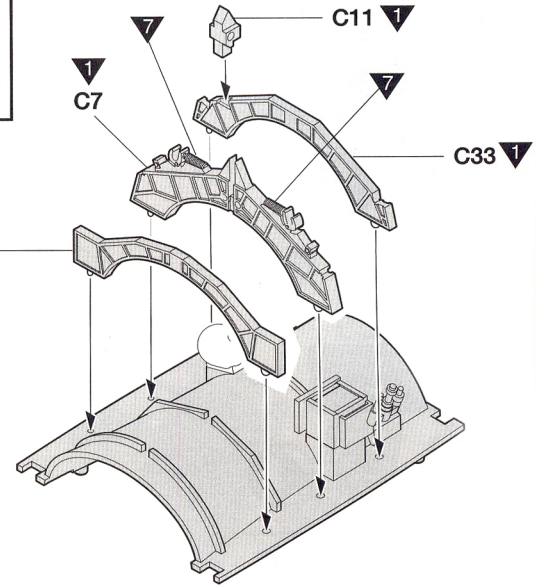
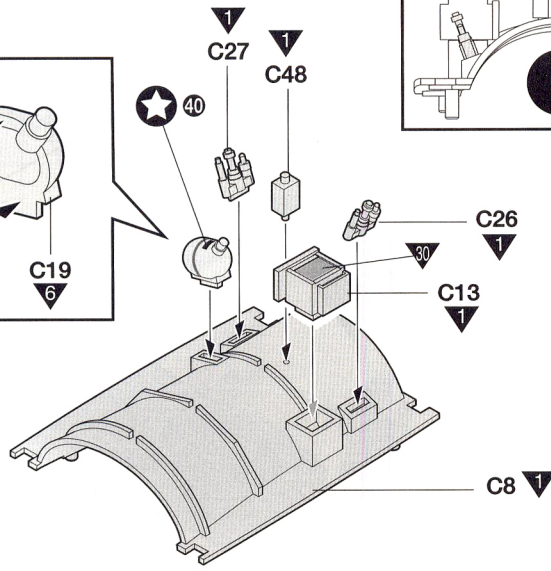
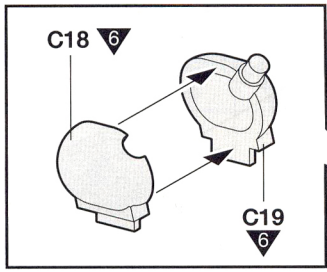

7

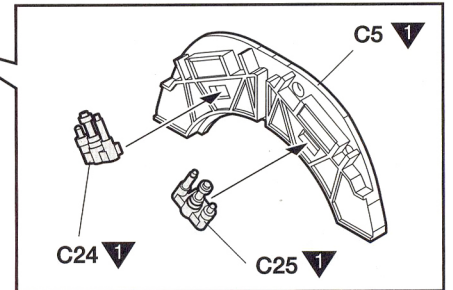
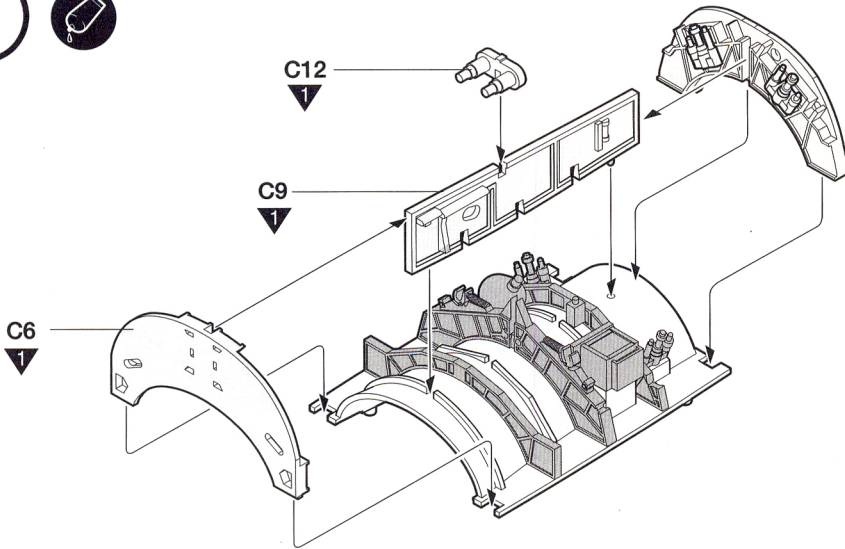

8

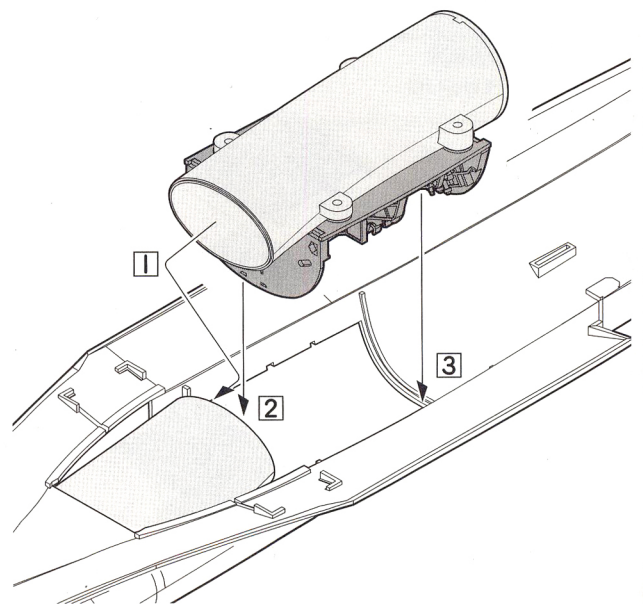
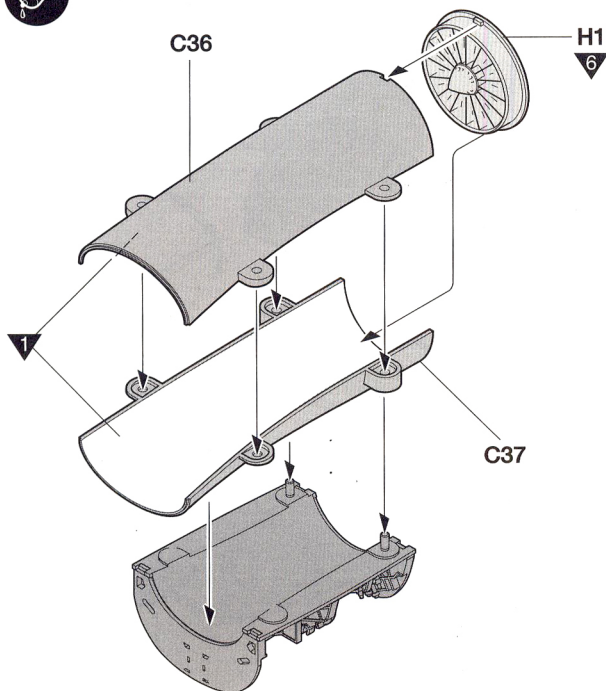

※ Attach 1 first.  
1 번부터 조립합니다.

9



\*( ) is opposite number.  
( )는 반대측 번호입니다.

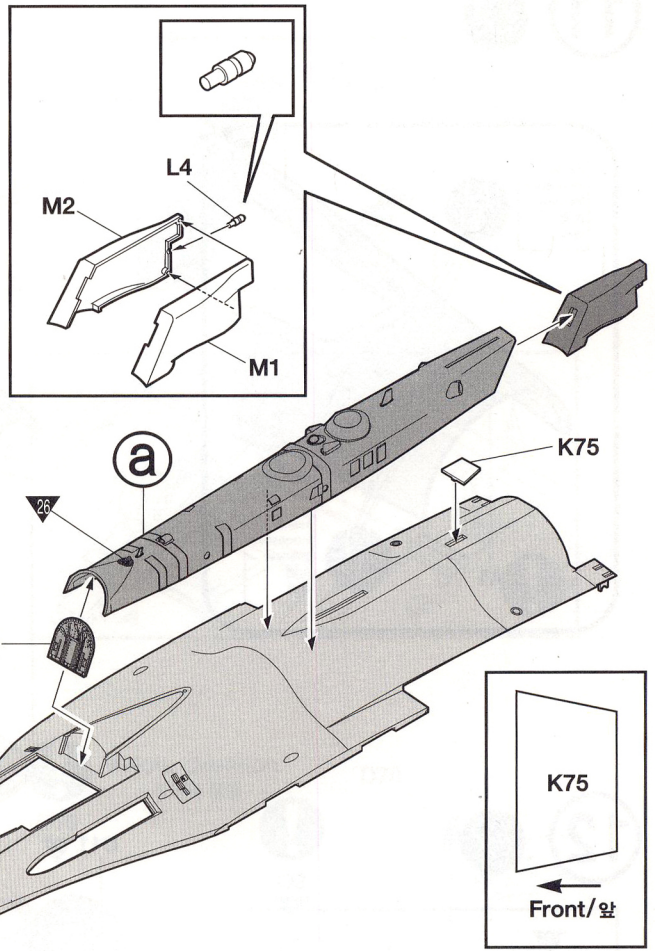
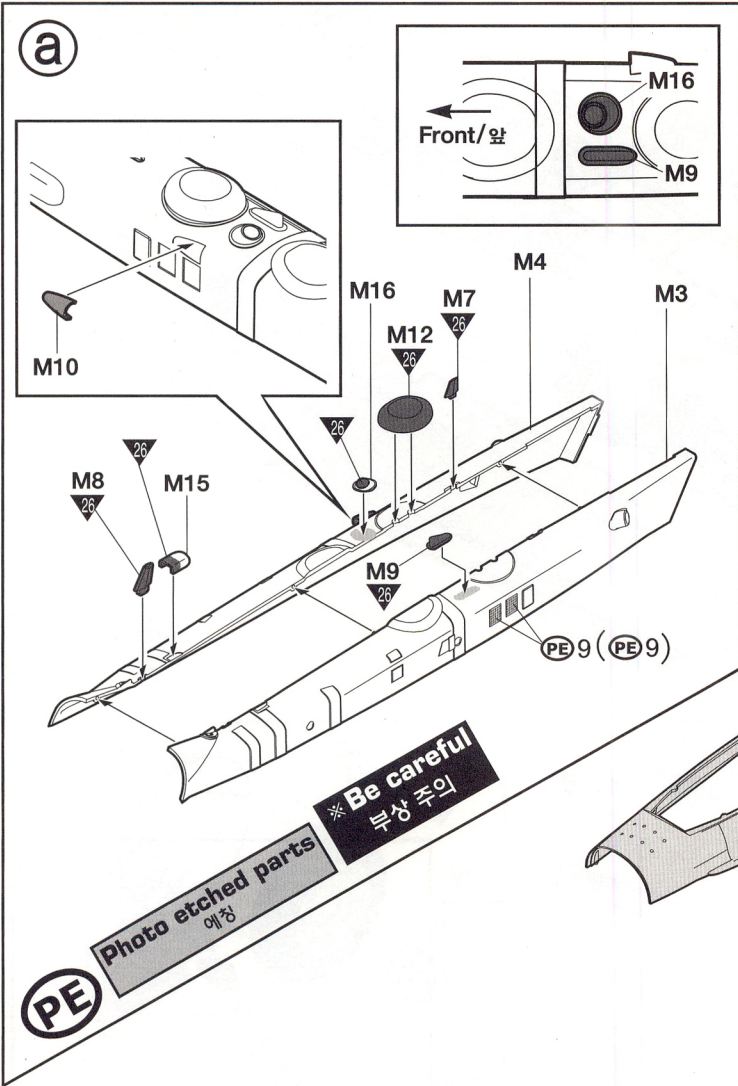

10

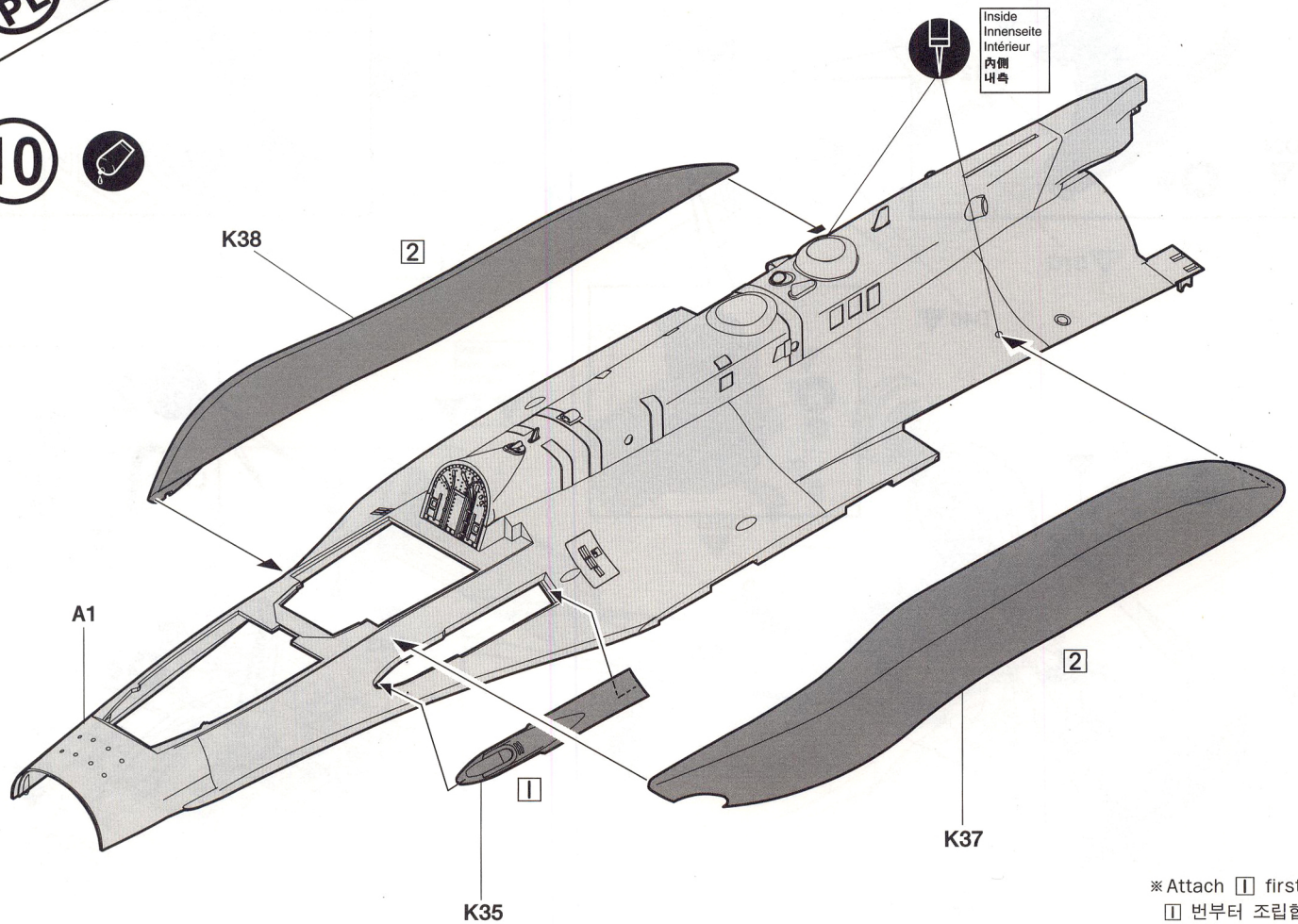

**11** 

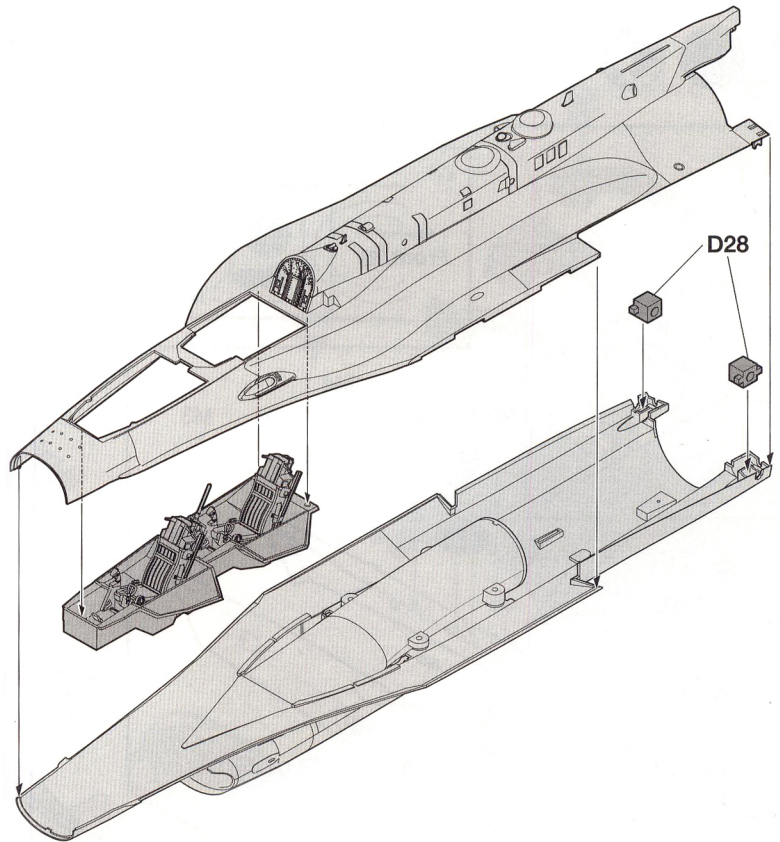
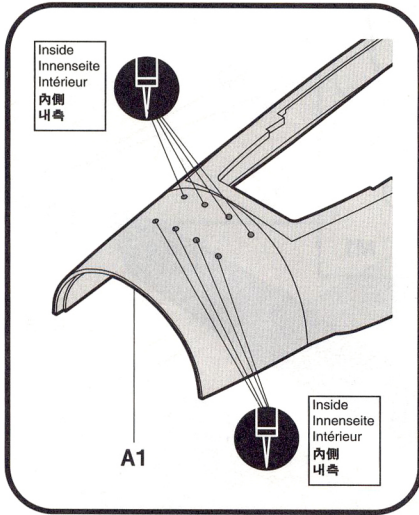

**12** 

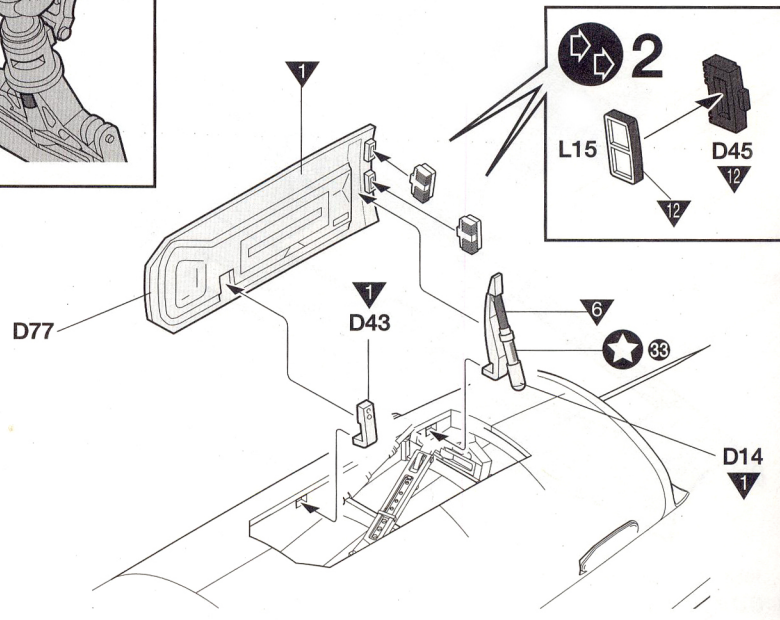
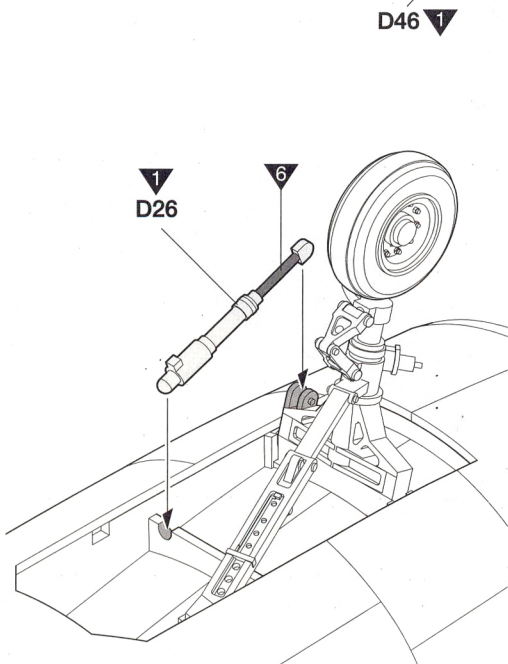
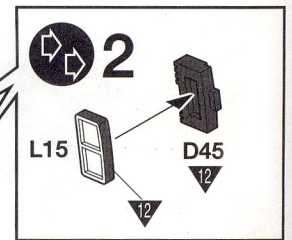
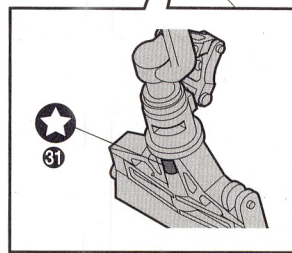
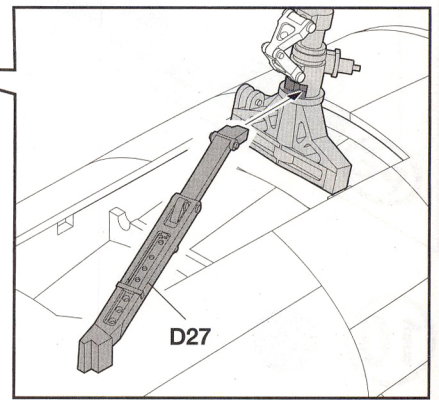
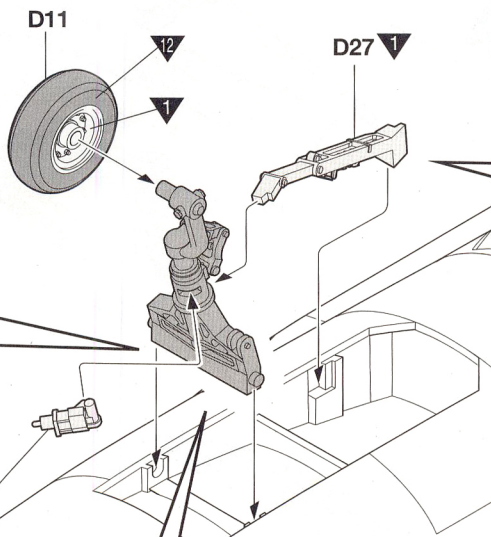
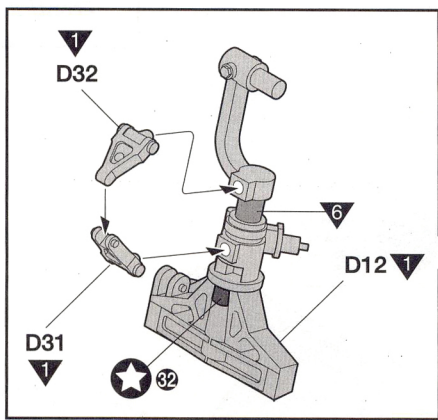

**13** 

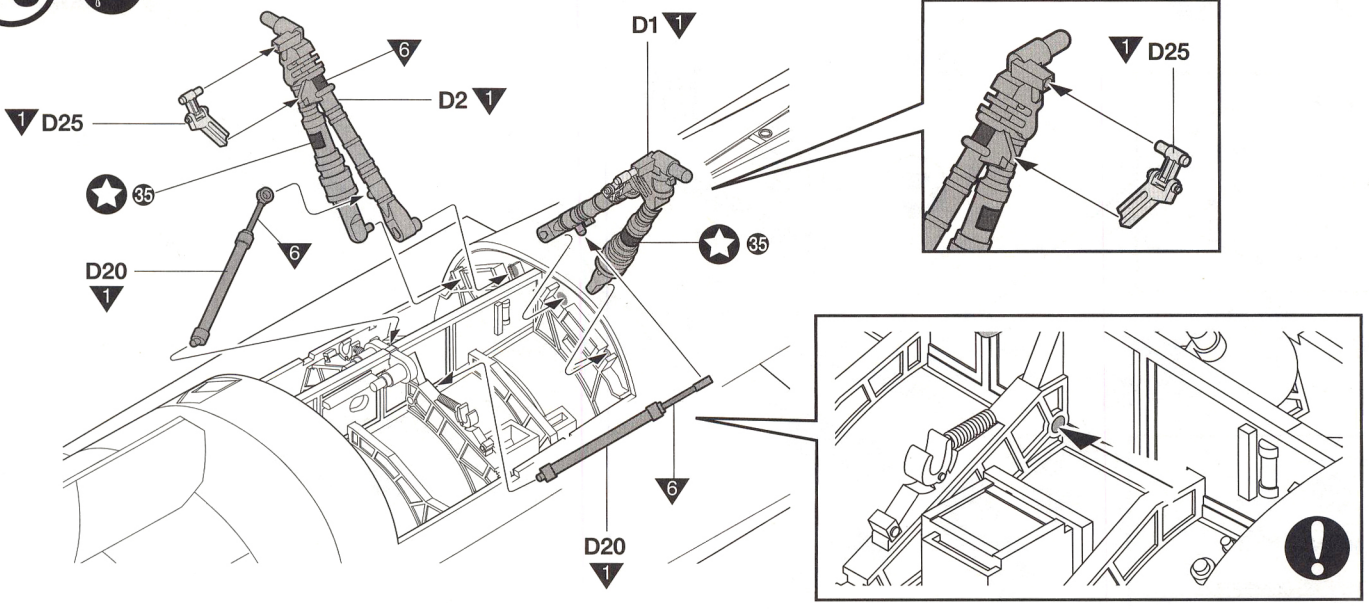

**14** 

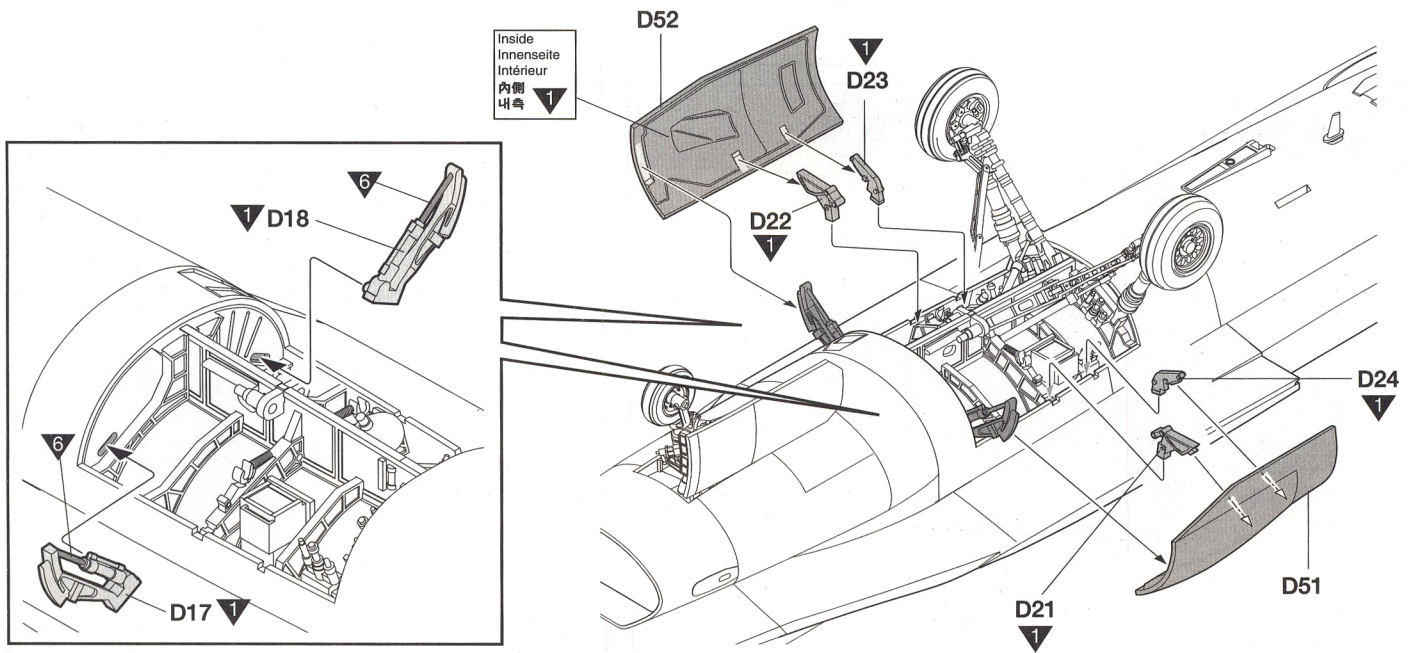
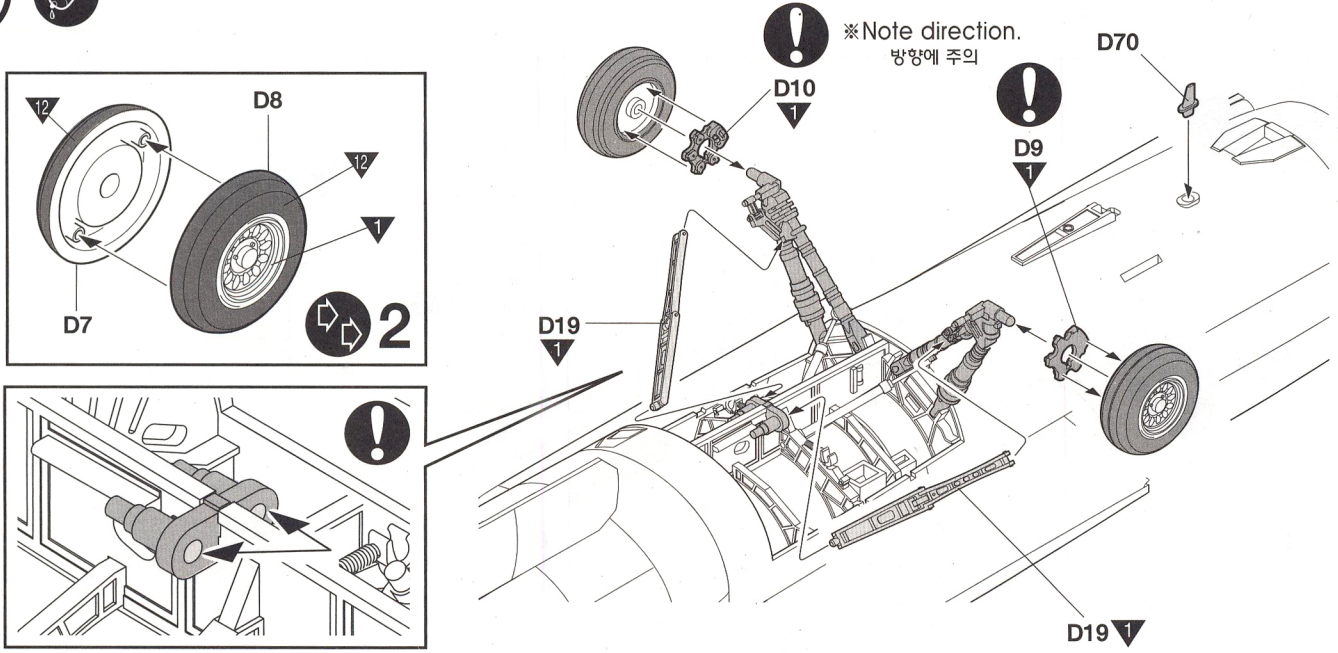

15

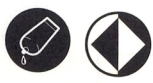

\*( ) is opposite number.  
( )는 반대쪽 번호입니다.

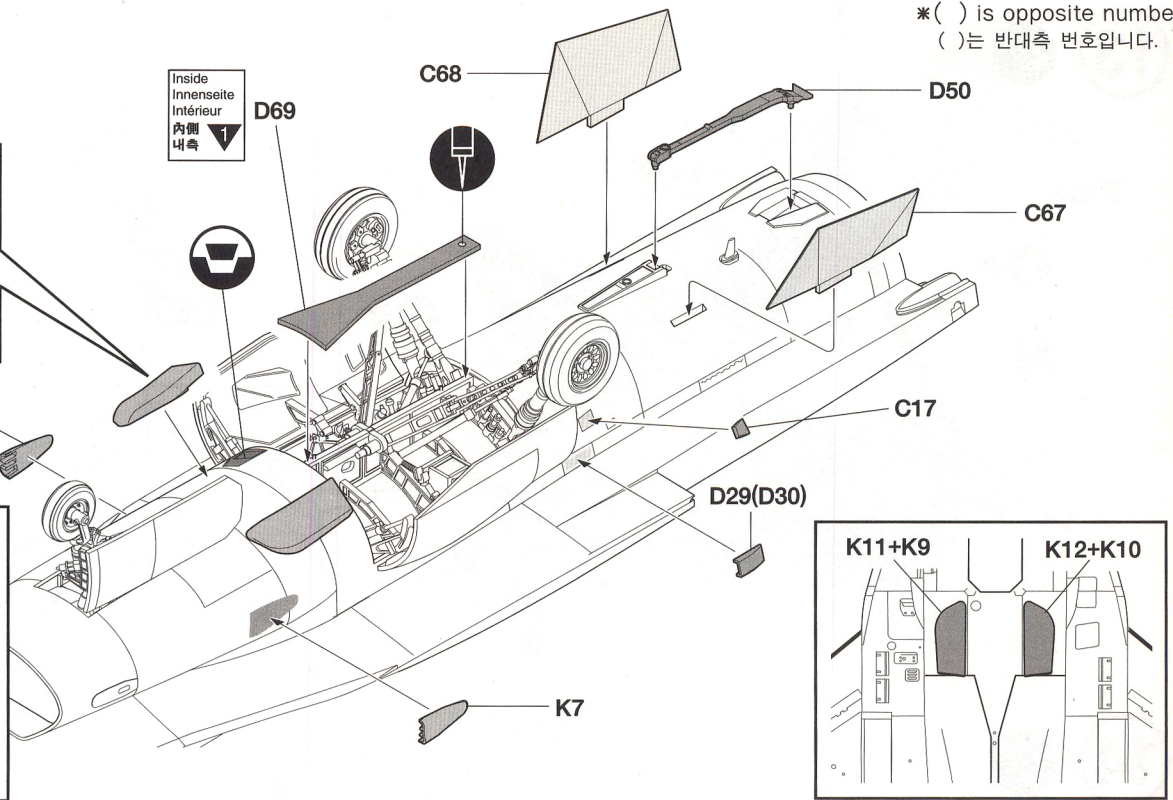
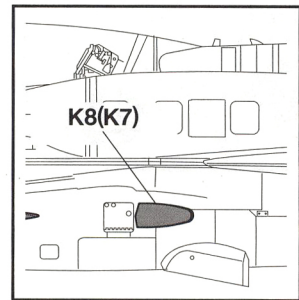
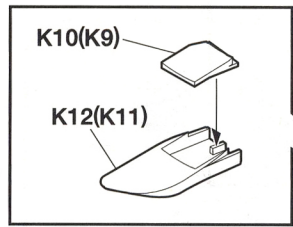

16

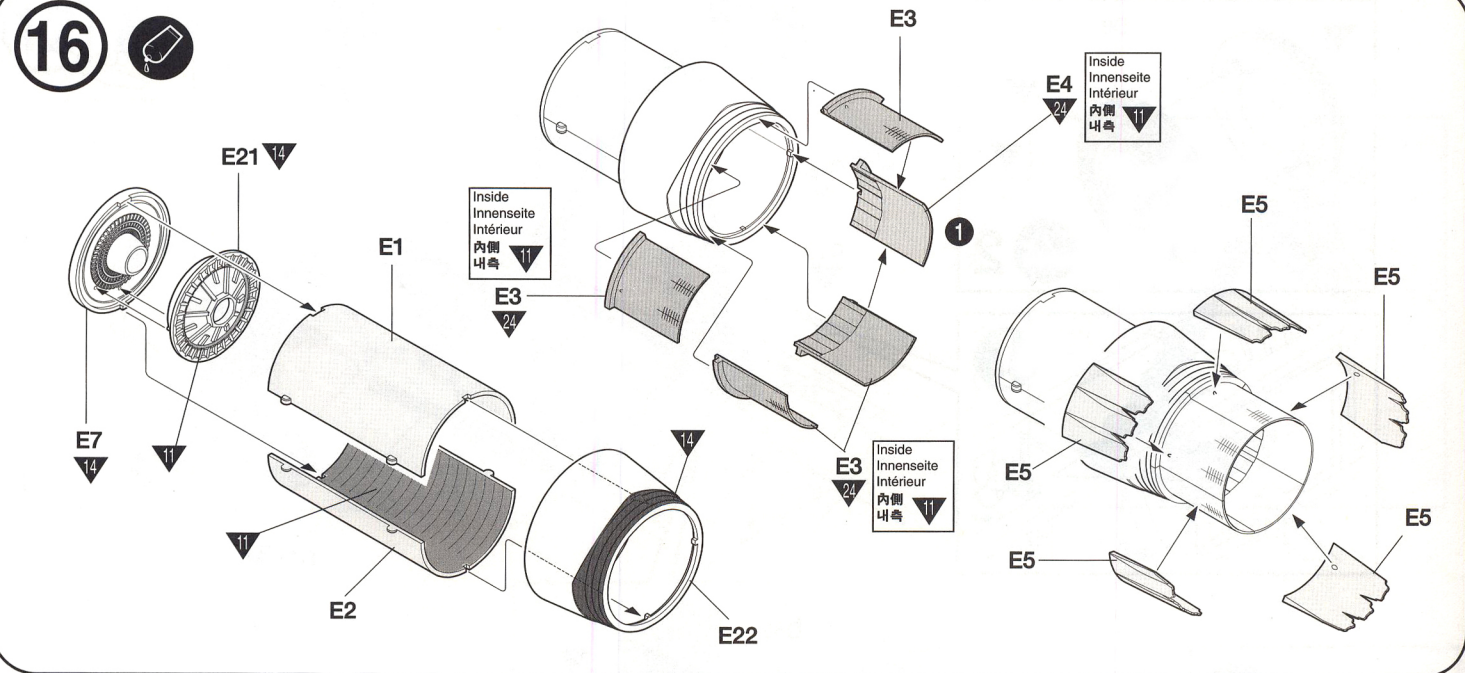

17

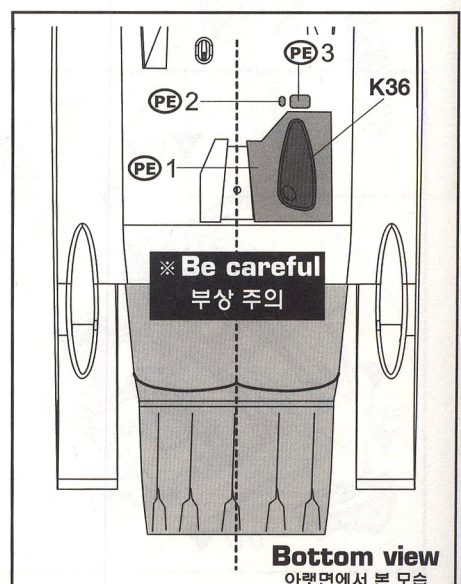
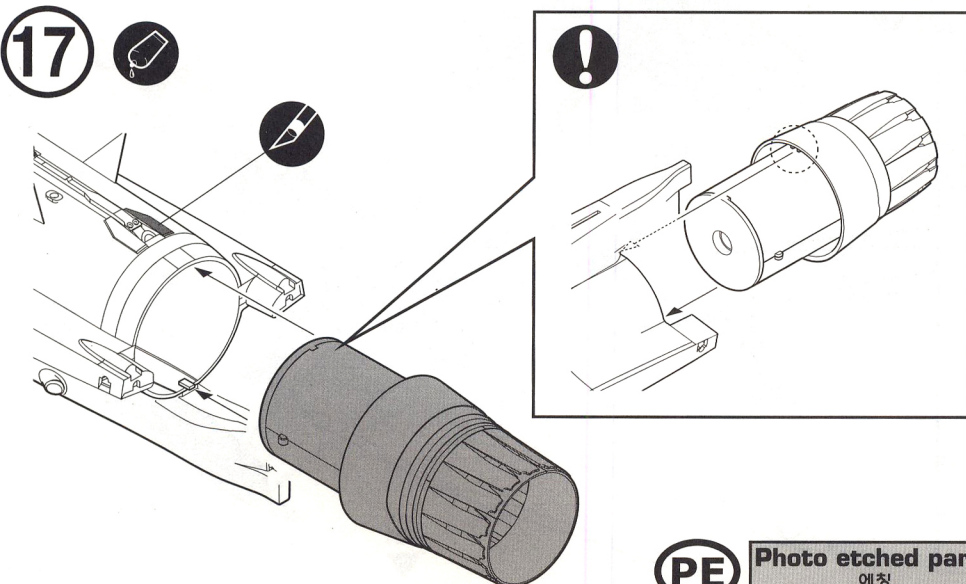



■ Closed/닫힌 상태

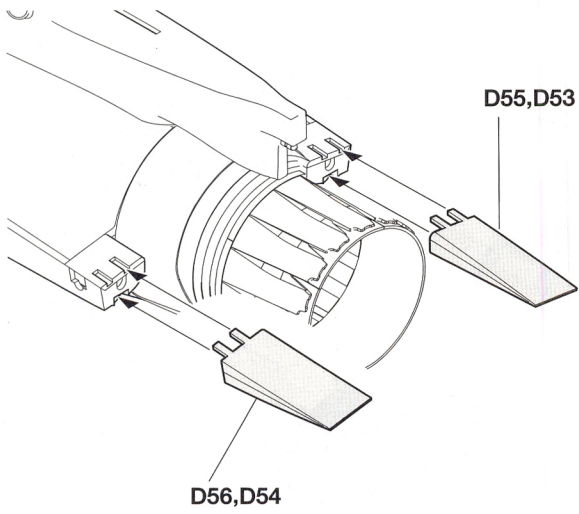

■ Open/열린 상태

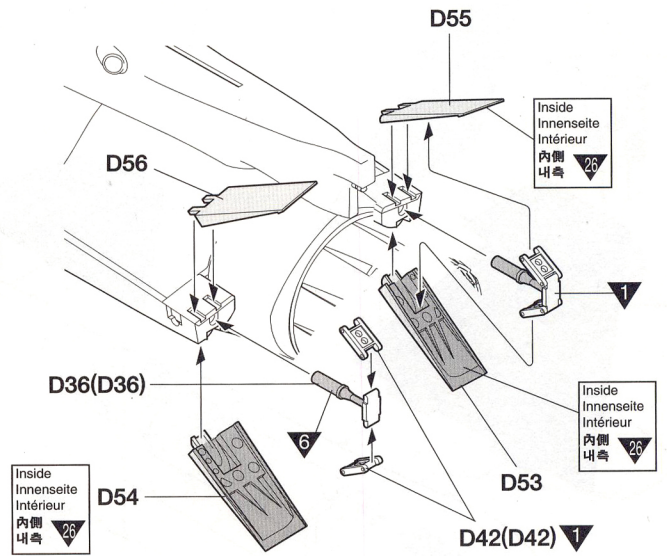

18



<Right>  
우

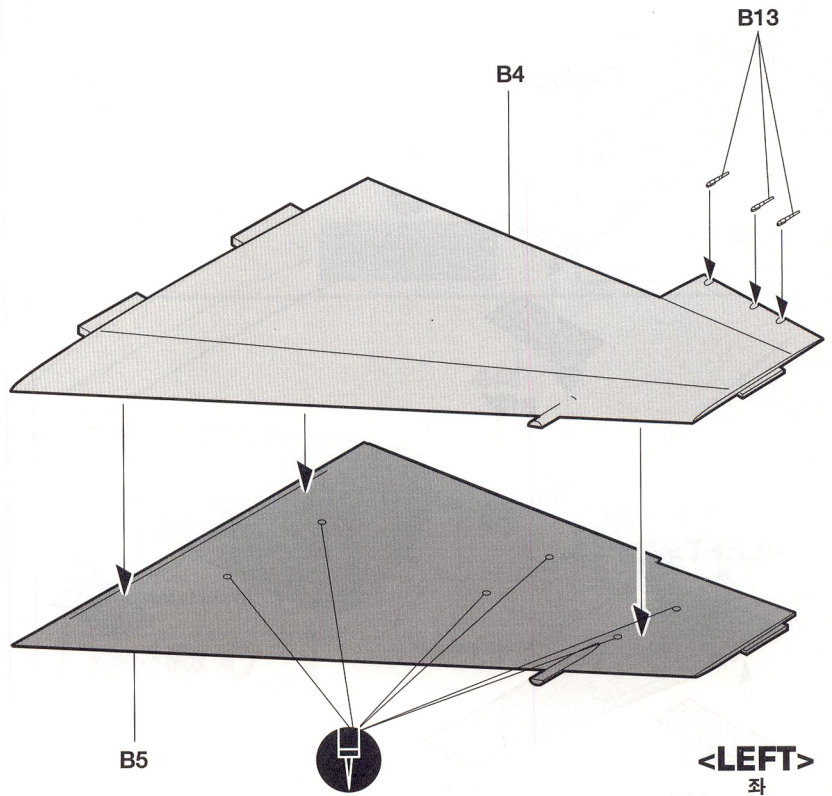
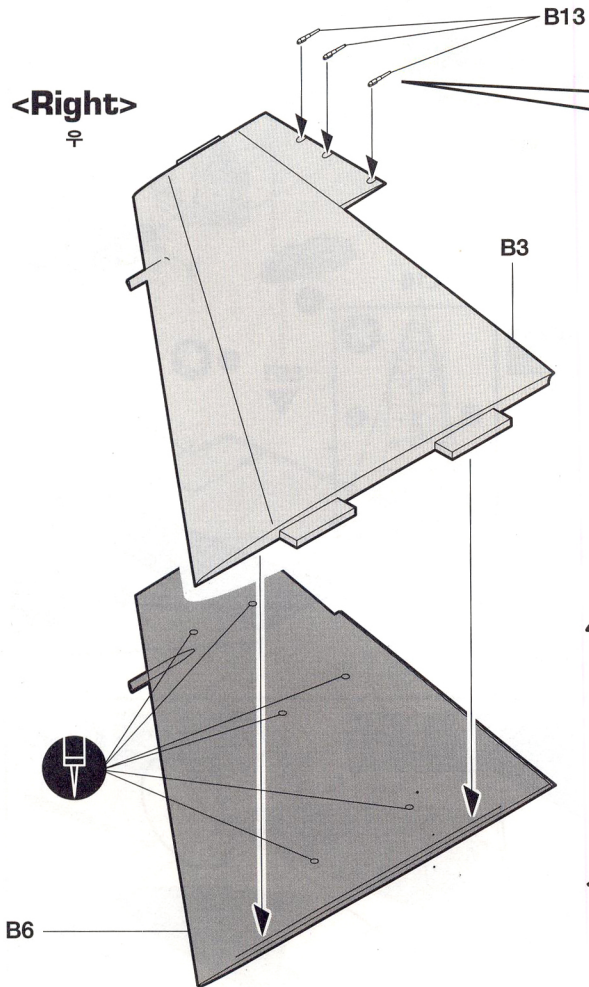

<LEFT>  
좌

19



\*( ) is opposite number.  
( )는 반대측 번호입니다.

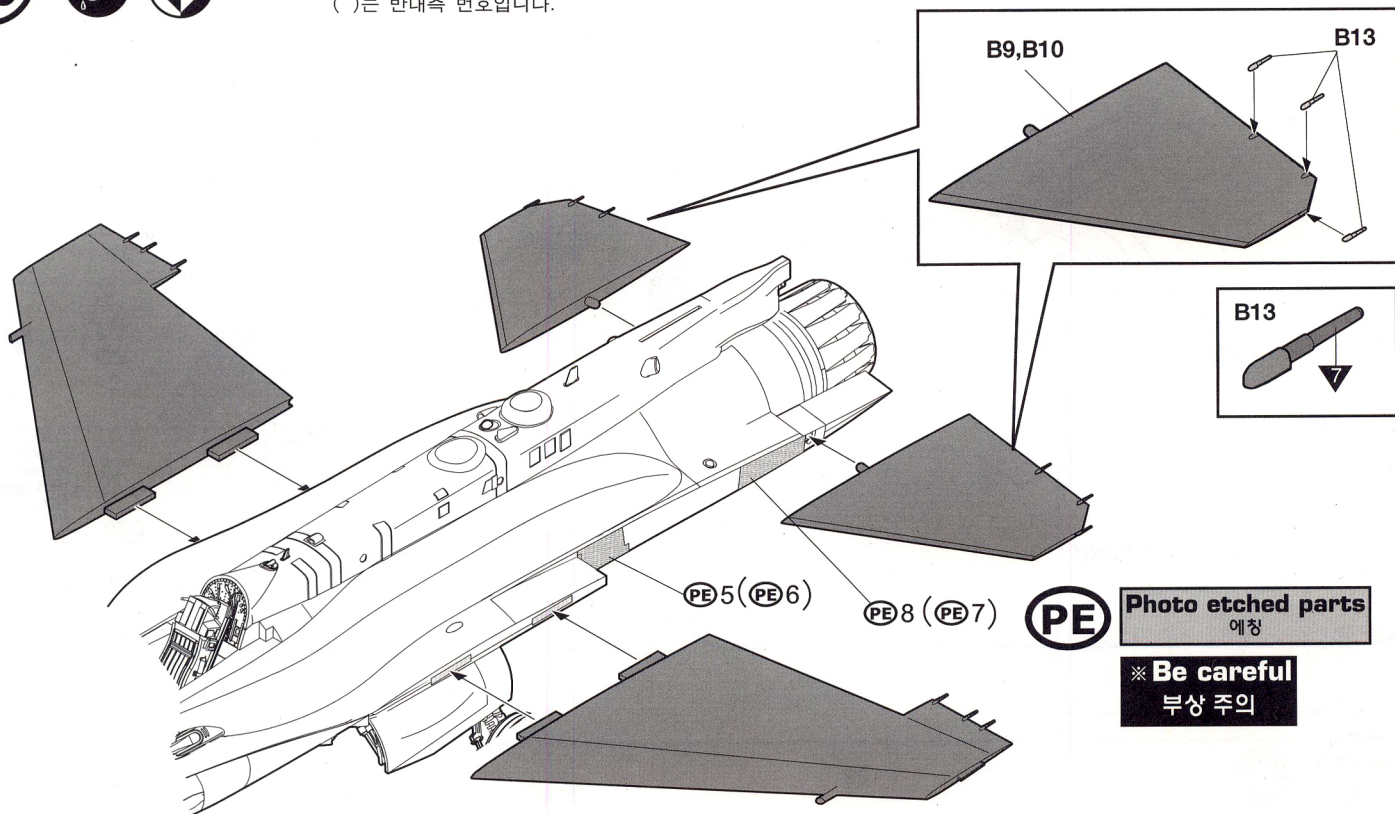

20

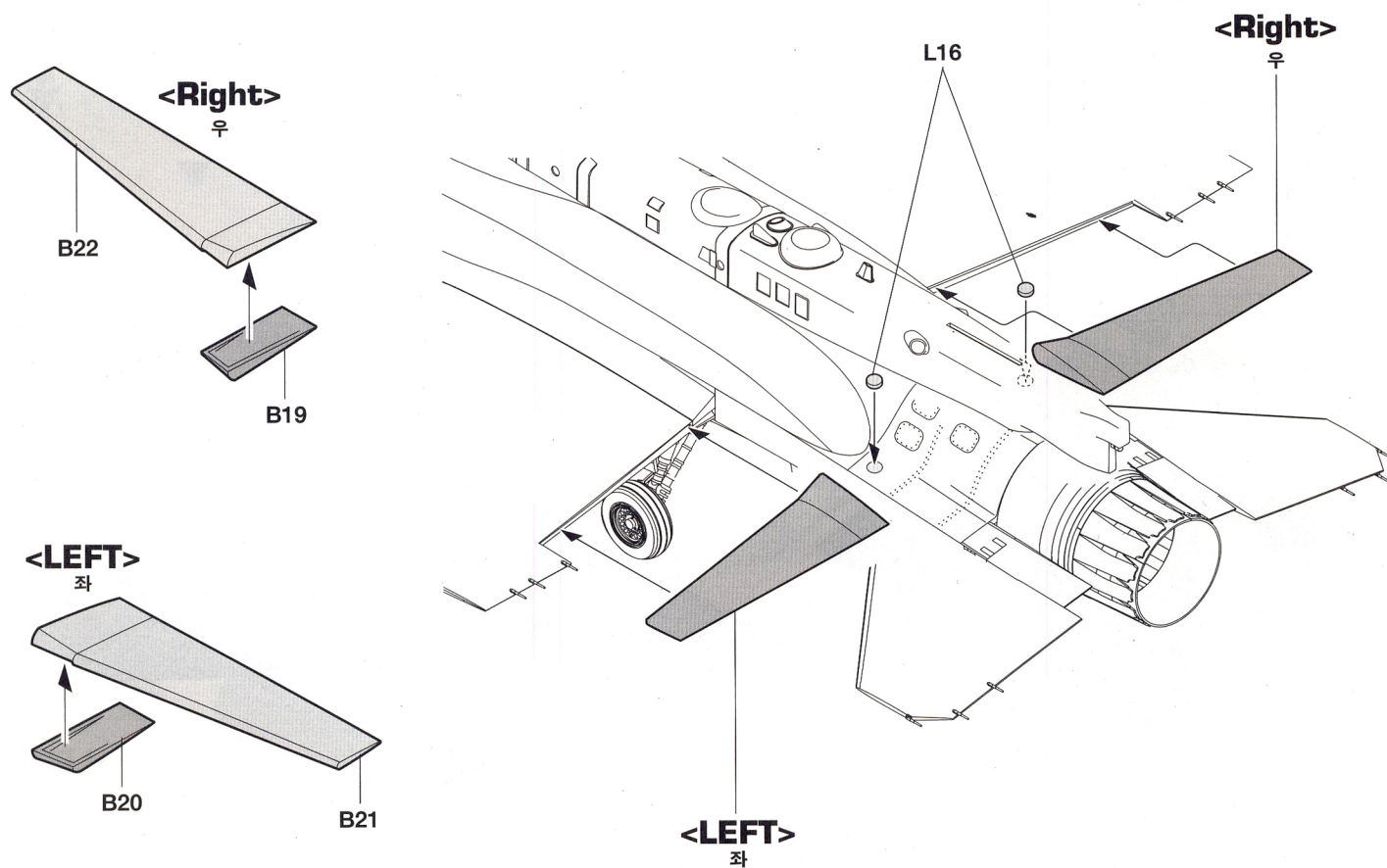

21

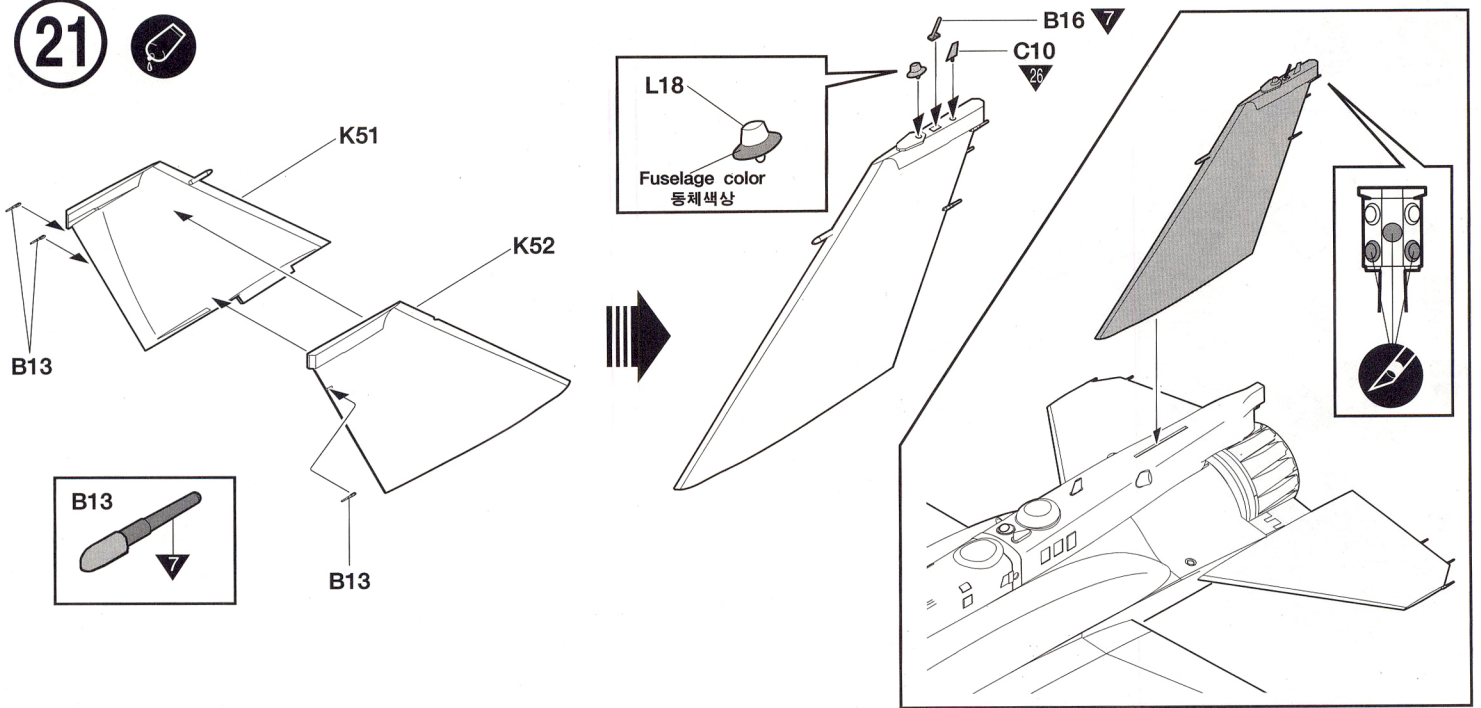

22

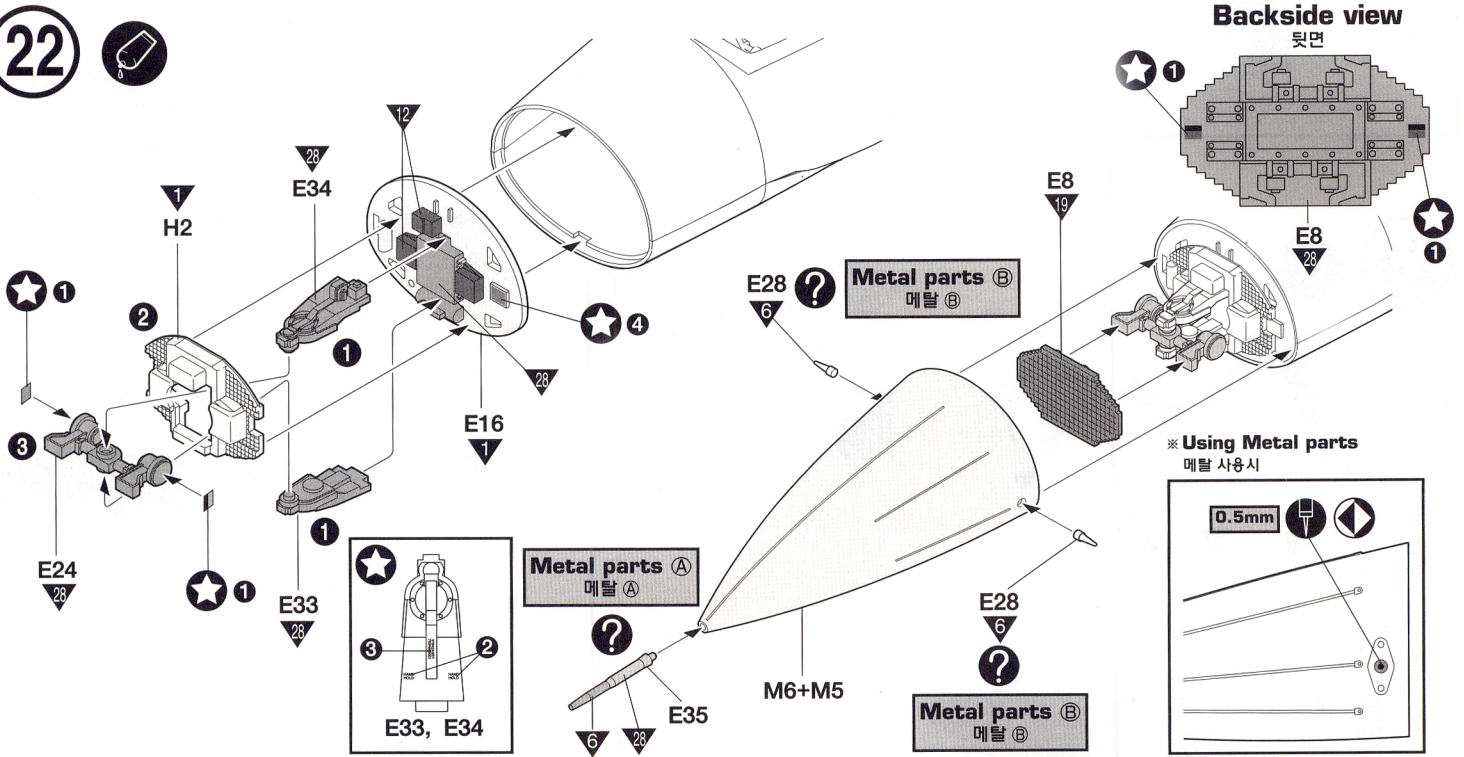

? ■ Open/열린 상태

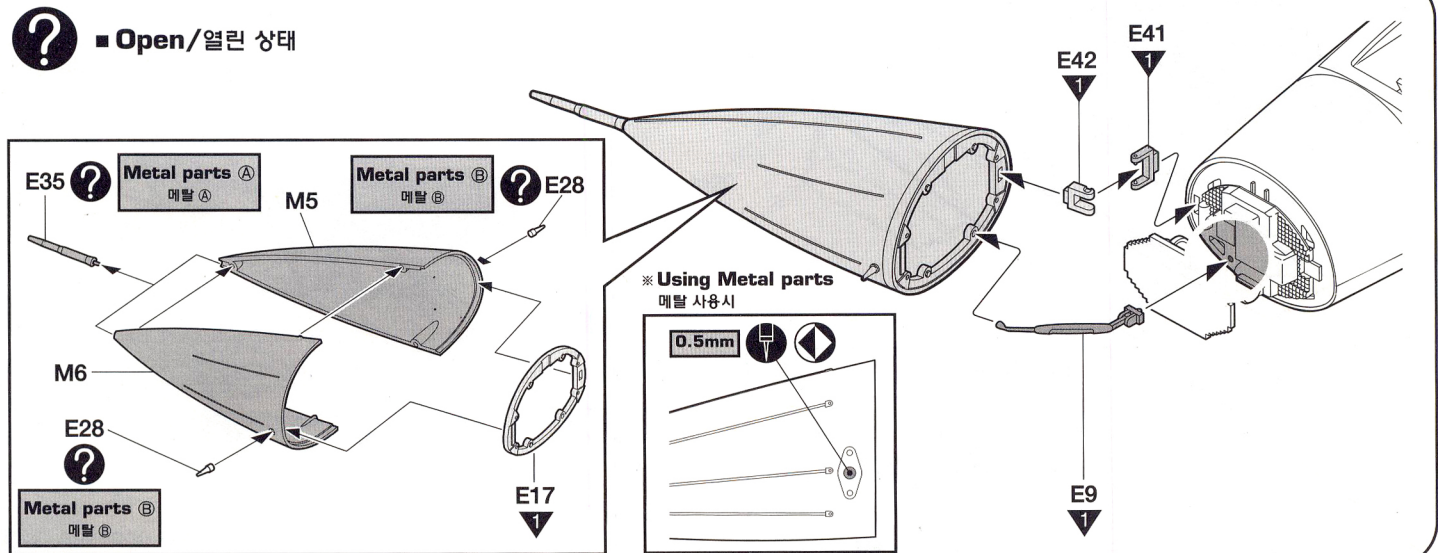

23

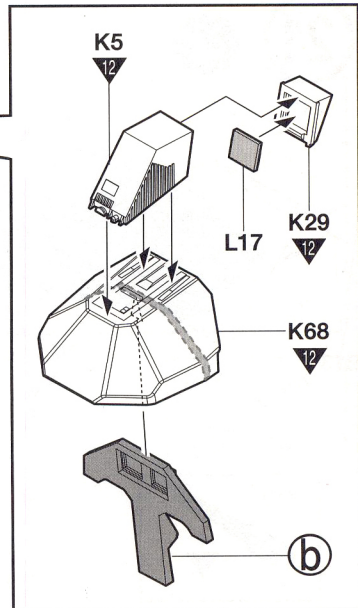
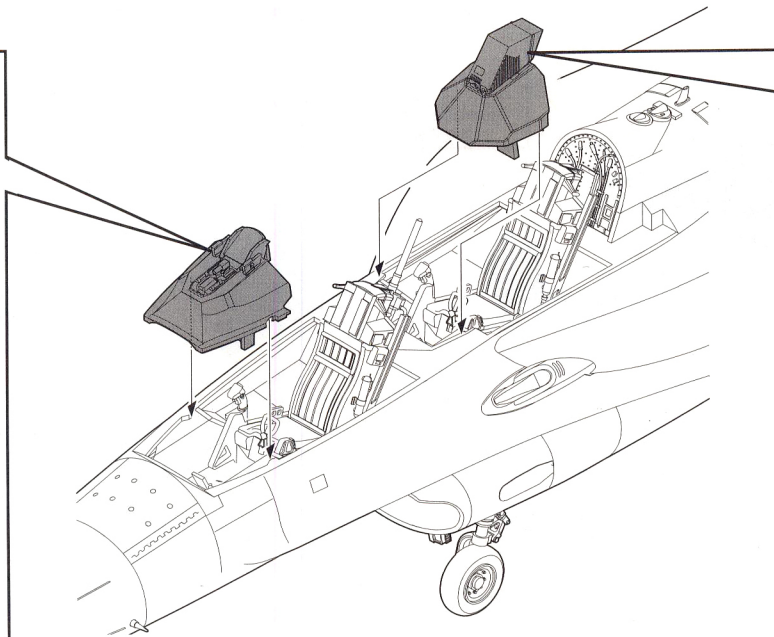
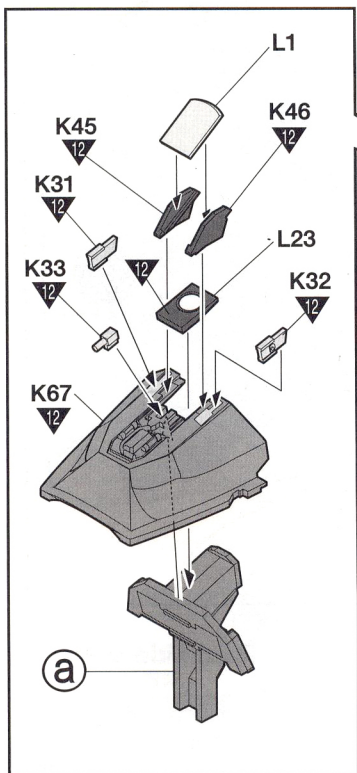

24

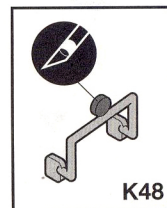
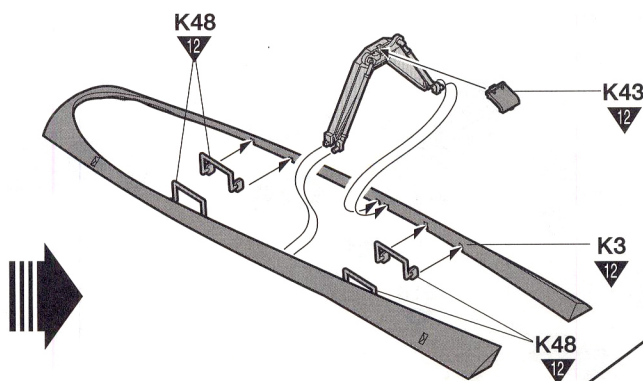
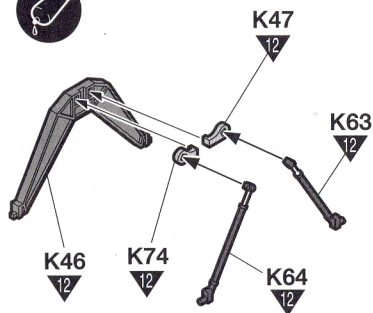

■ Open  
캐노피 열린상태

Inside  
Innenseite  
Intérieur  
내측  
★ 16

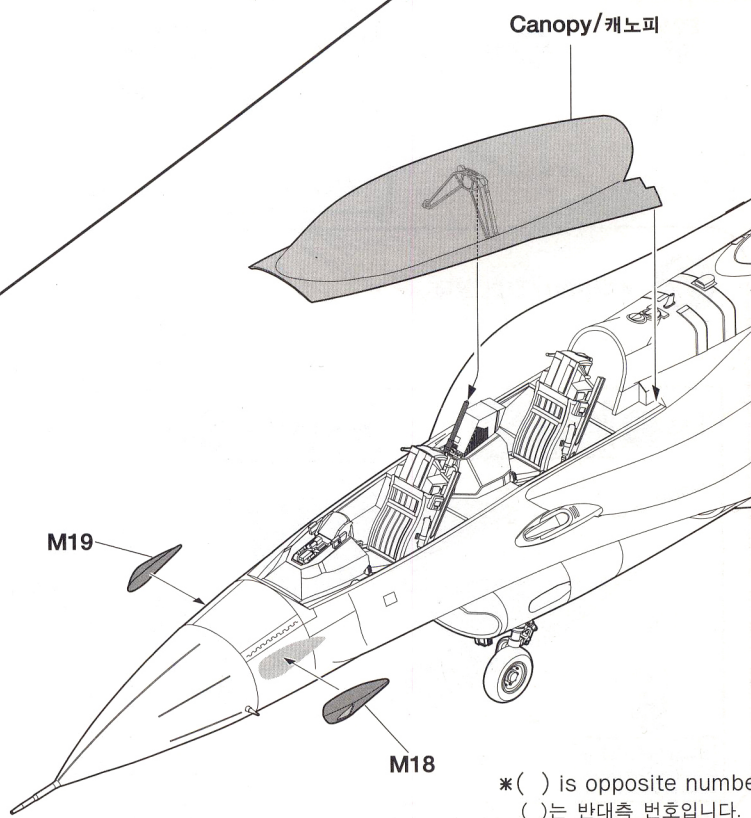
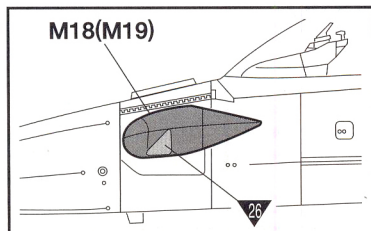
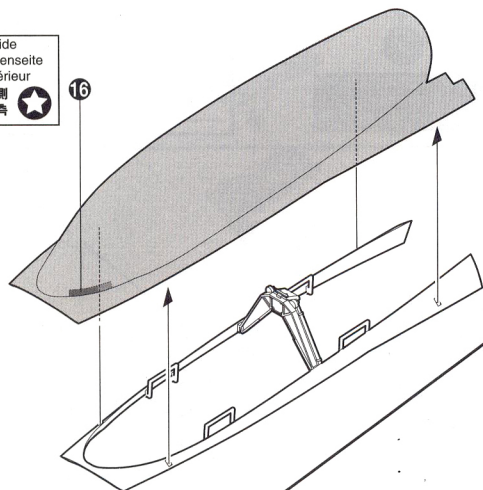

\*( ) is opposite number.  
( )는 반대측 번호입니다.

25

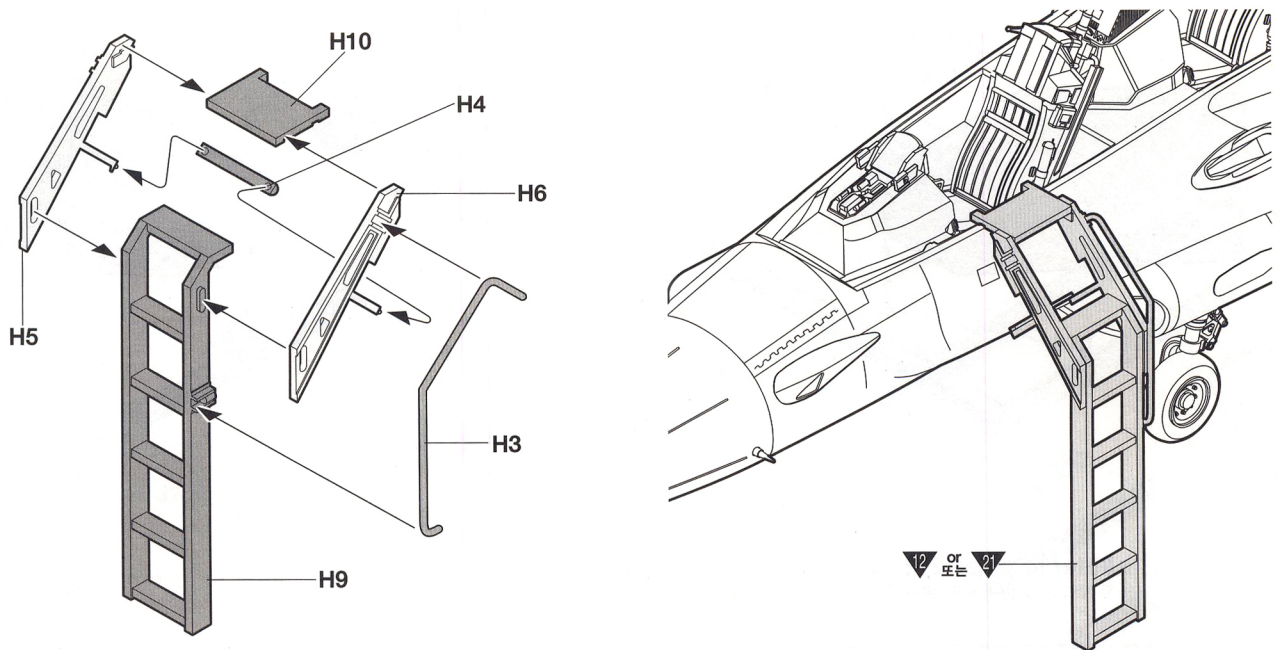

26

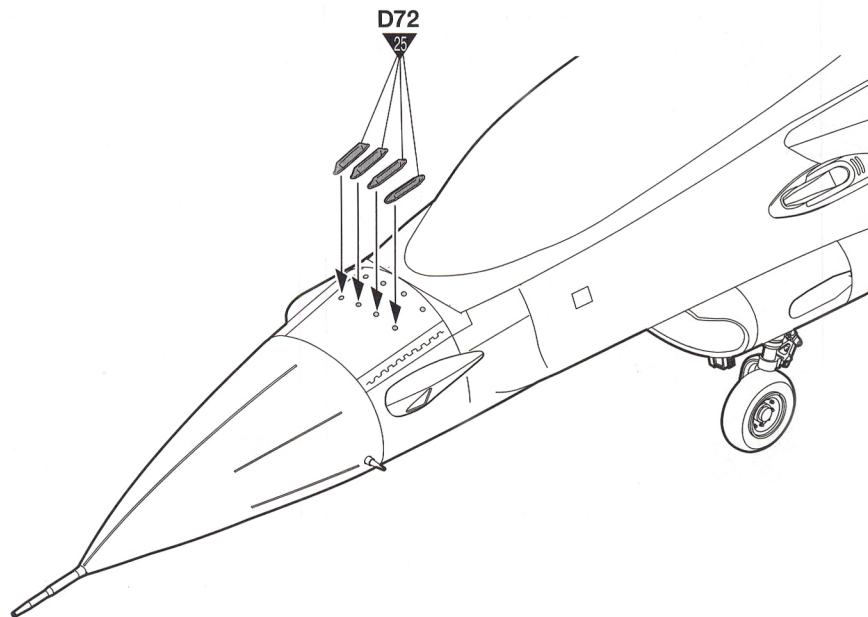

PE

Photo etched parts  
에칭

M11

PE 4

M17

※ Be careful  
부상 주의

10mm

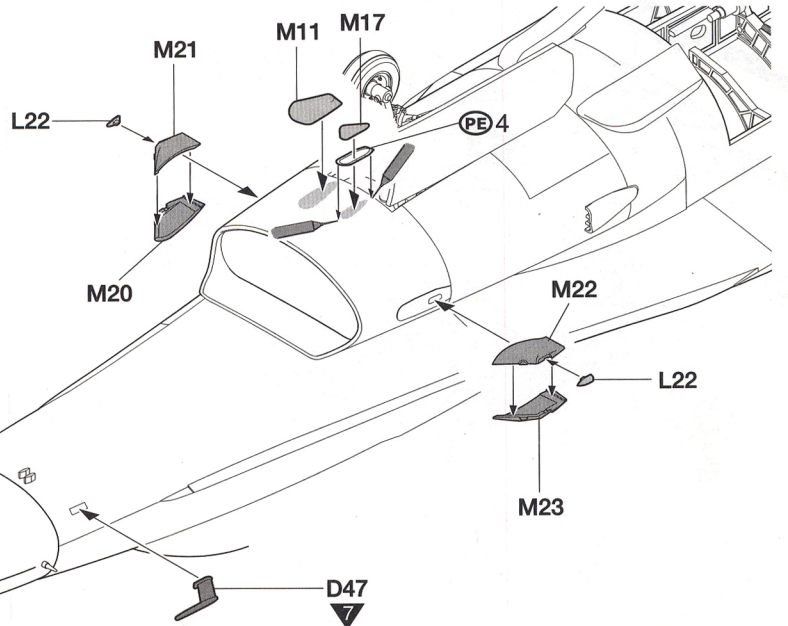

27 

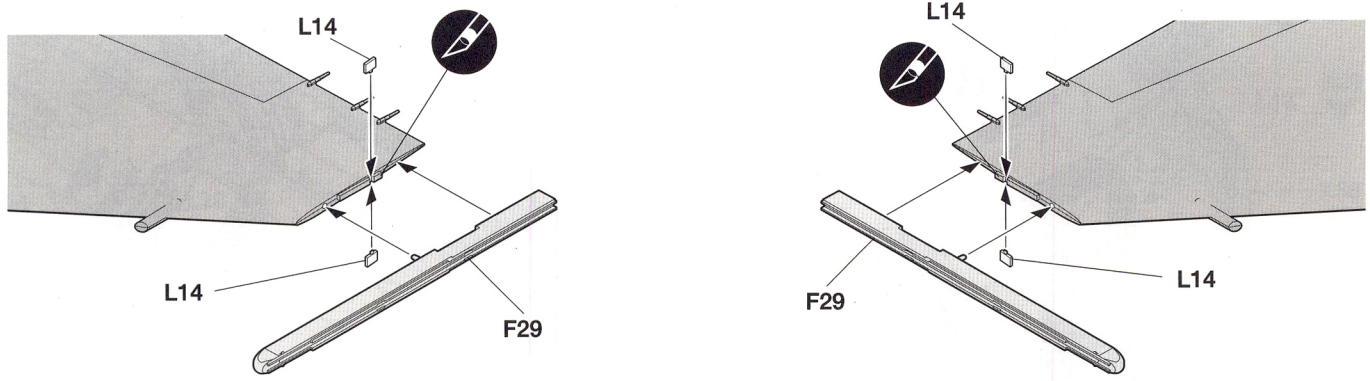

28 

※ Refer to page 21 & 22 for painting & decal placement.  
무장의 색칠 및 전사지 붙이기는 21, 22 페이지를 참조하십시오.

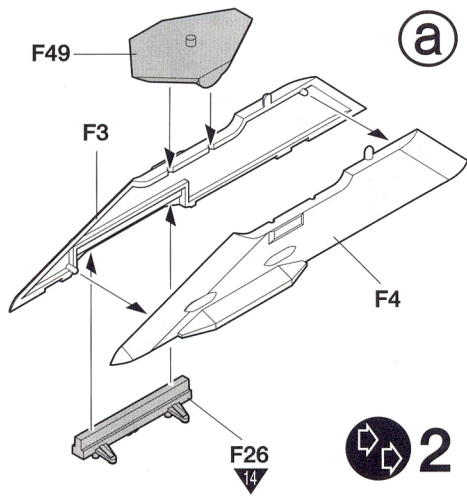

■ 370gal. Wing Fuel Tank Pylon  
370갤런 주익용 연료탱크 파일런

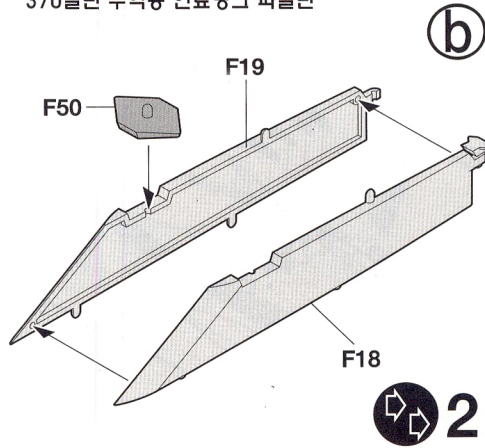

■ 600gal. Wing Fuel Tank Pylon  
600갤런 주익용 연료탱크 파일런

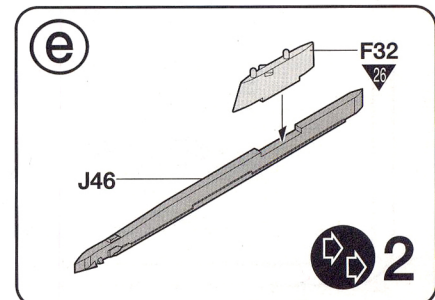
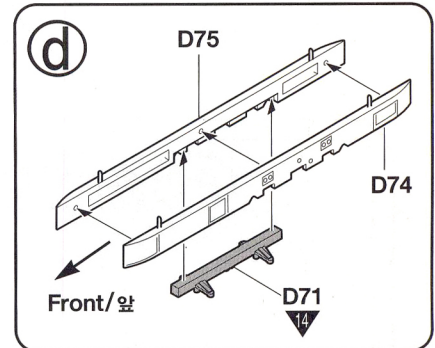
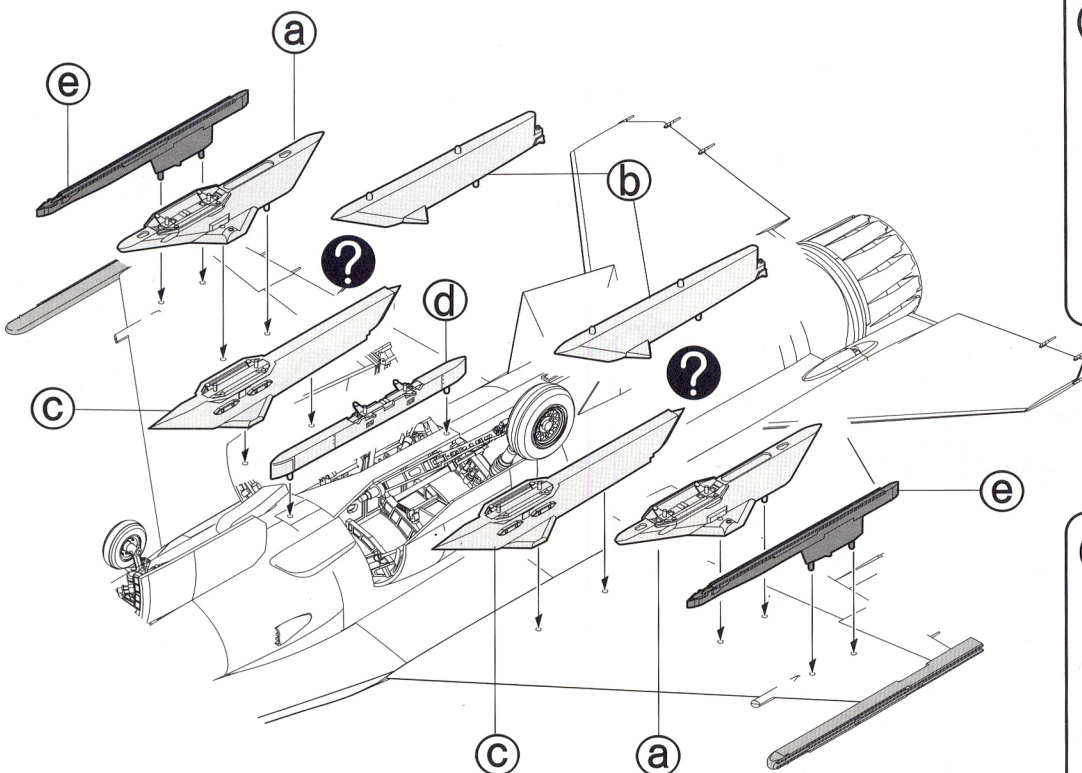
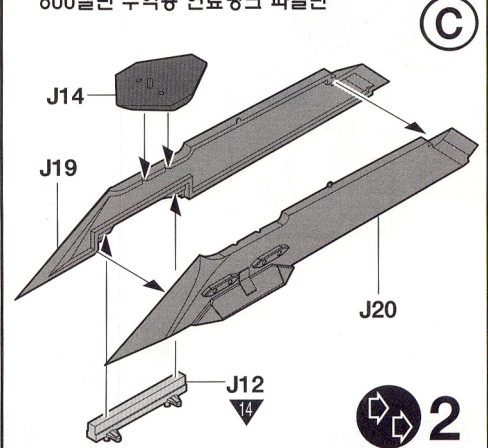

■ **GBU-31(V)3 JDAM**  
GBU-31(V)3 「제이덤」 GPS 유도폭탄

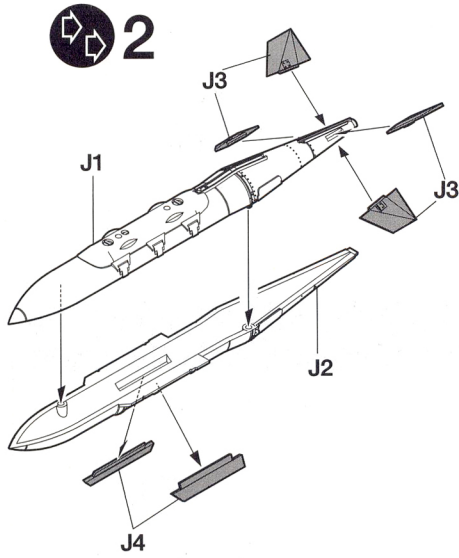

■ **GBU-31(V)1 JDAM**  
GBU-31(V)1 「제이덤」 GPS 유도폭탄

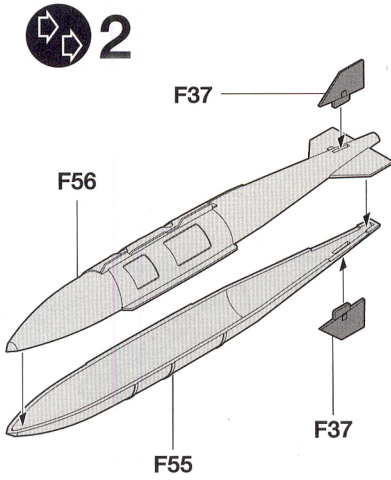

■ **AGM-130**

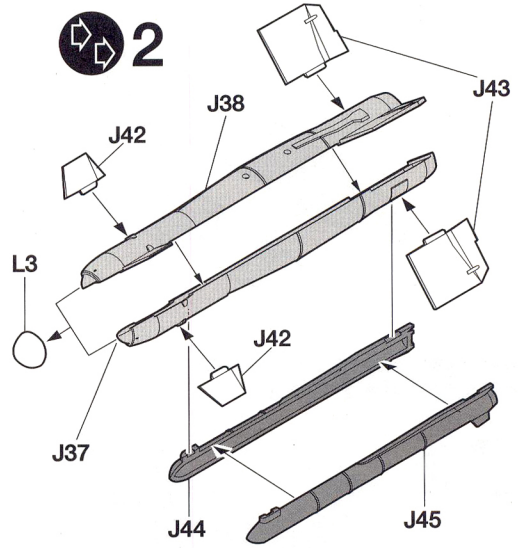

■ **GBU-38 JDAM (500lb)**  
GBU-38 「제이덤」 GPS 유도폭탄(500파운드급)

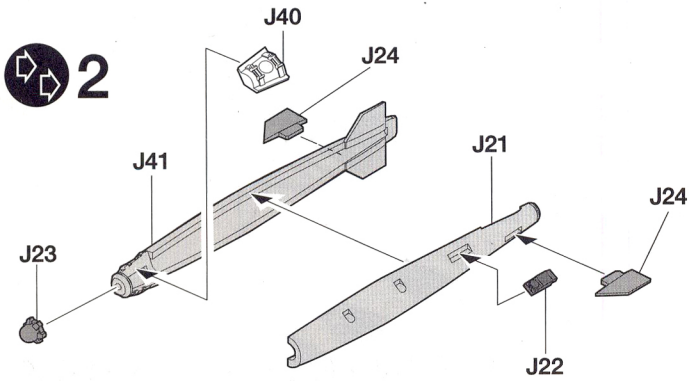

■ **GBU-12 Paveway II (500lb)**  
GBU-12 페이브웨이 II 레이저 유도탄(500파운드급)

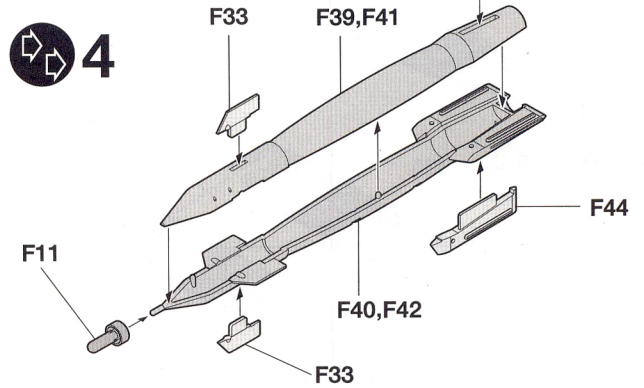

■ **TER(Triple Ejector Rack)**  
TER(3연장 폭탄장착대)

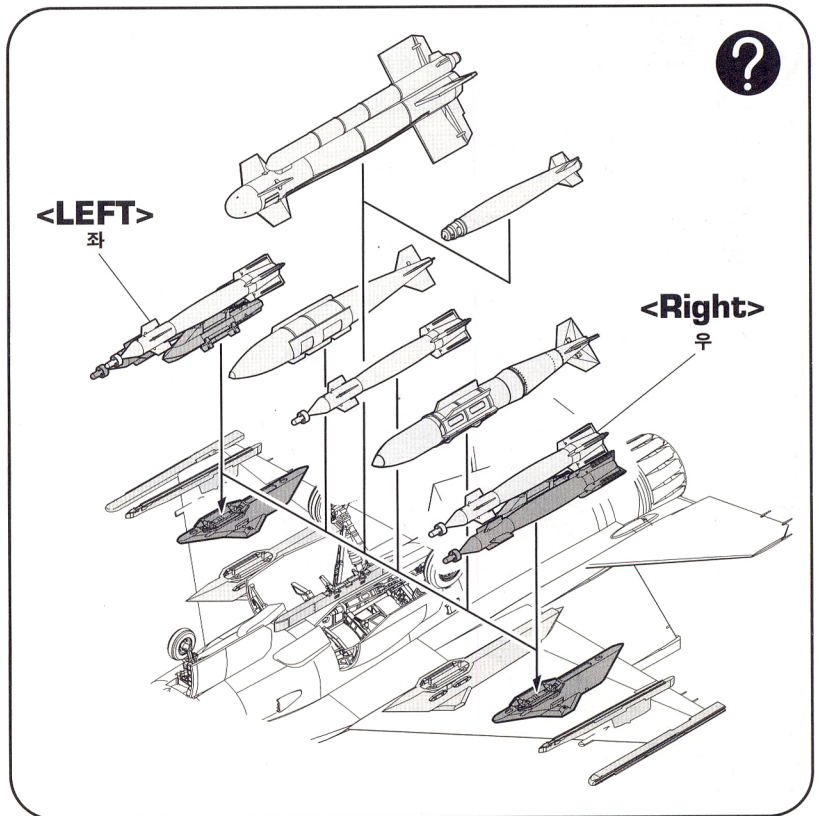
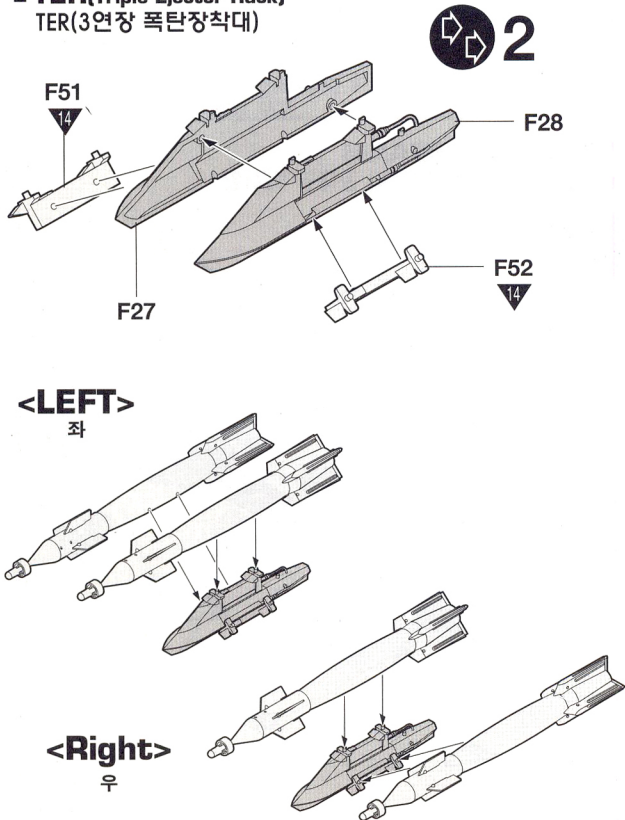

30 

■ 300gal. Center Line Fuel Tank  
300갤런 중체하면 연료탱크

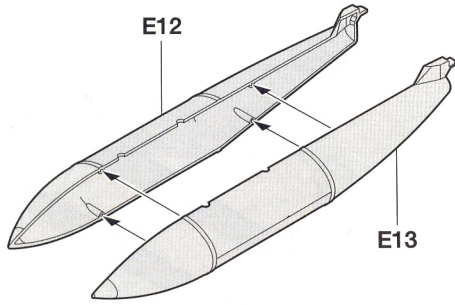

■ 370gal. Wing Fuel Tank  
370갤런 주익용 연료탱크

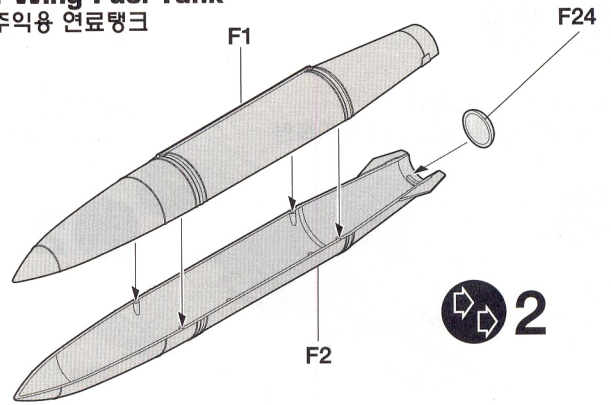

■ 600gal. Wing Fuel Tank  
600갤런 주익용 연료탱크

 2

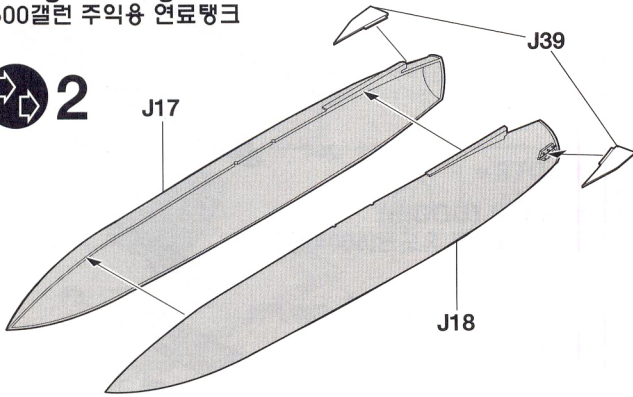

■ AN/AXQ-14

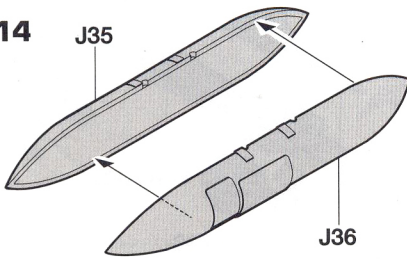

**b** Pylon+370gal. Wing Fuel Tank

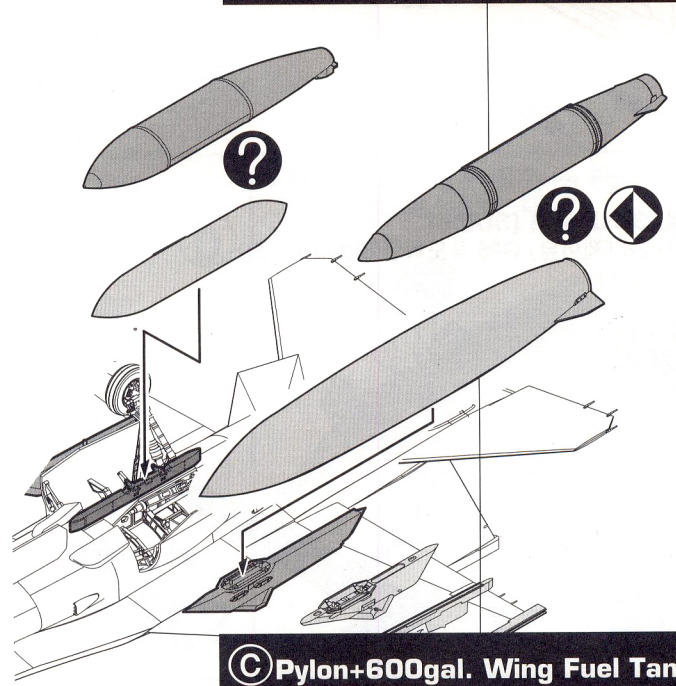

**c** Pylon+600gal. Wing Fuel Tank

31 

■ AIM-120B AMRAAM  
AIM-120B 「암람」 중거리 공대공 미사일

 2

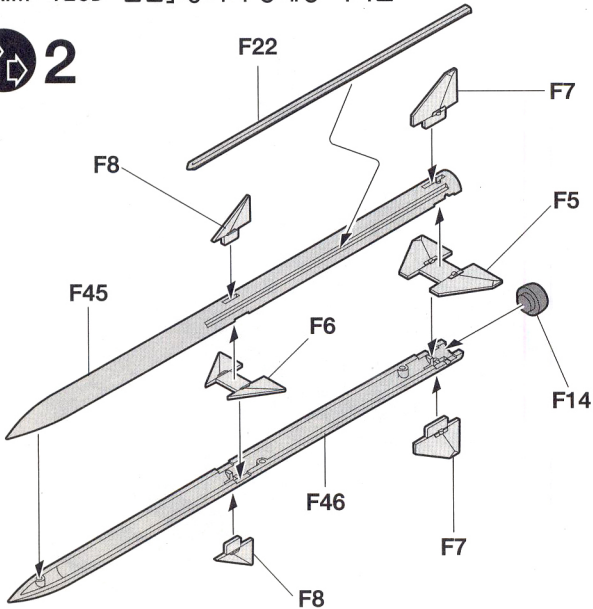

■ PYTHON-4 AMRAAM  
PYTHON-4 「암람」 단거리 공대공 미사일

 2

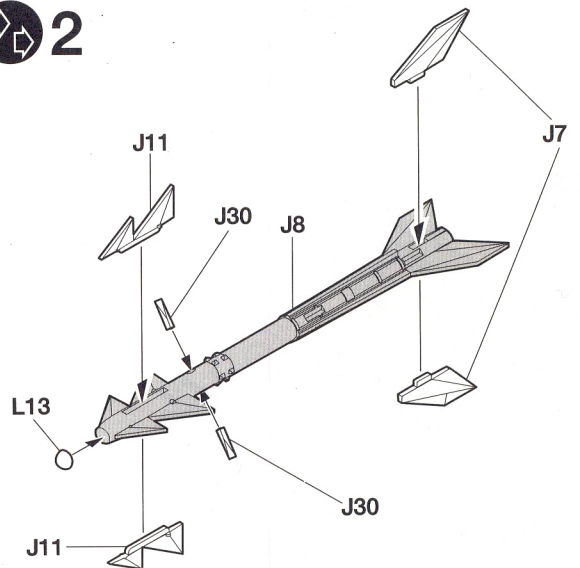



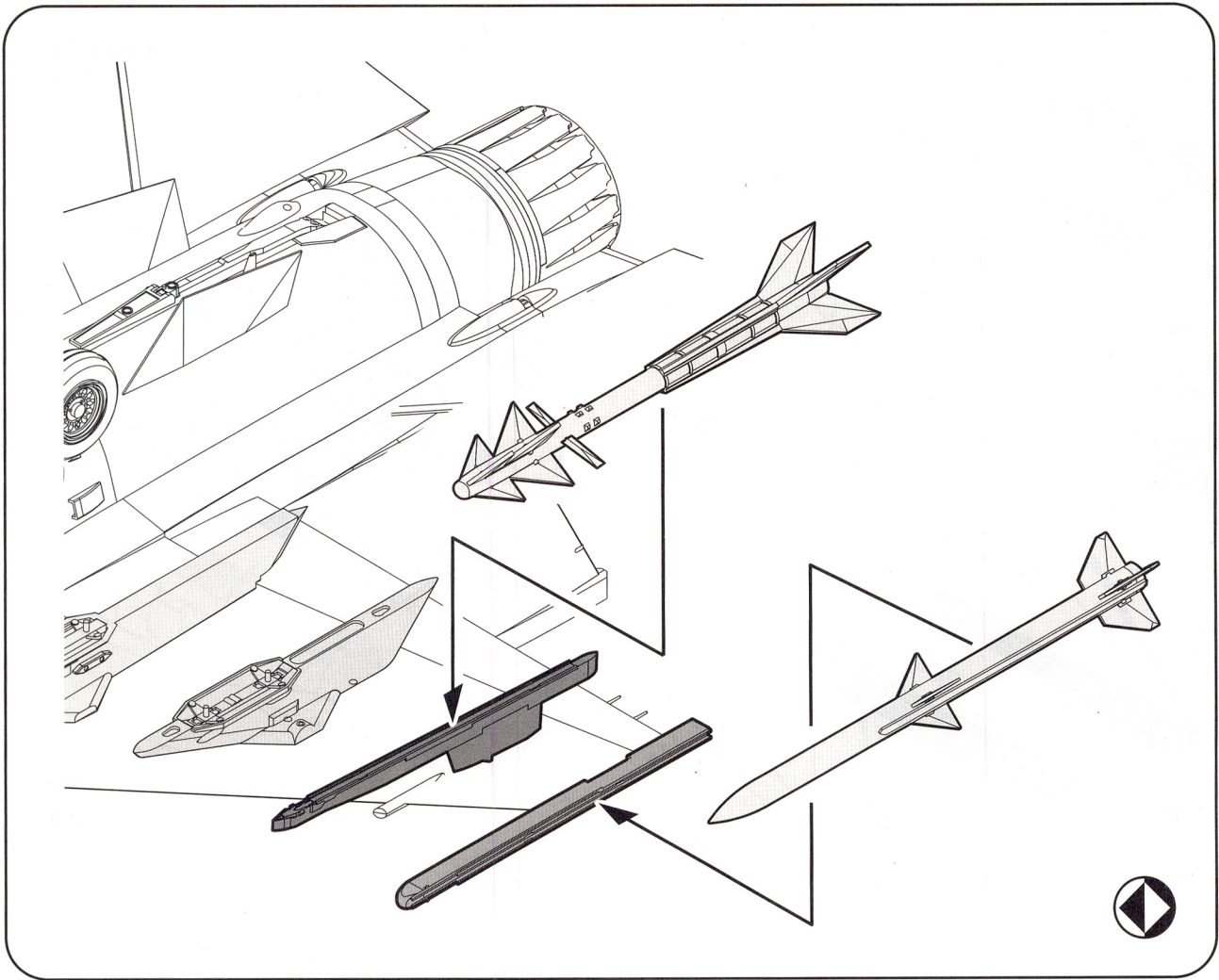

■ LiteningII Targeting Pod  
라이트닝II 타겟팅 포드

■ AN/AAQ-13 LANTIRN Navigation Pod  
AN/AAQ-13 「랜턴」 항법용 포드

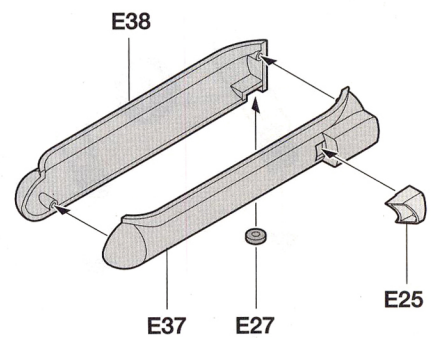
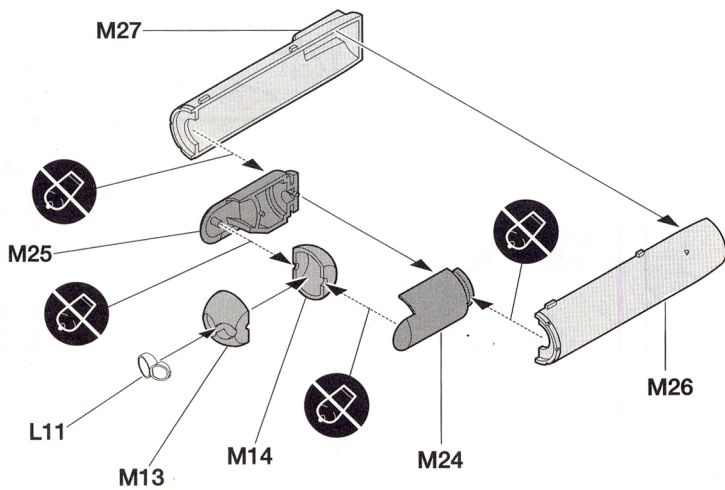

(a)

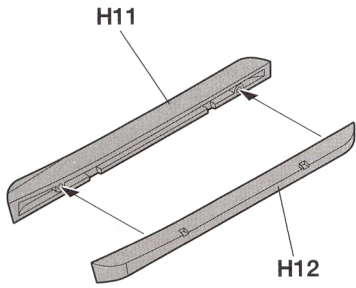

**AN/AAQ-13 LANTIRN Navigation Pod**  
AN/AAQ-13 「랜턴」 항법용 포드

**LiteningII Targeting Pod**  
라이트닝II 타겟팅 포드

(b)

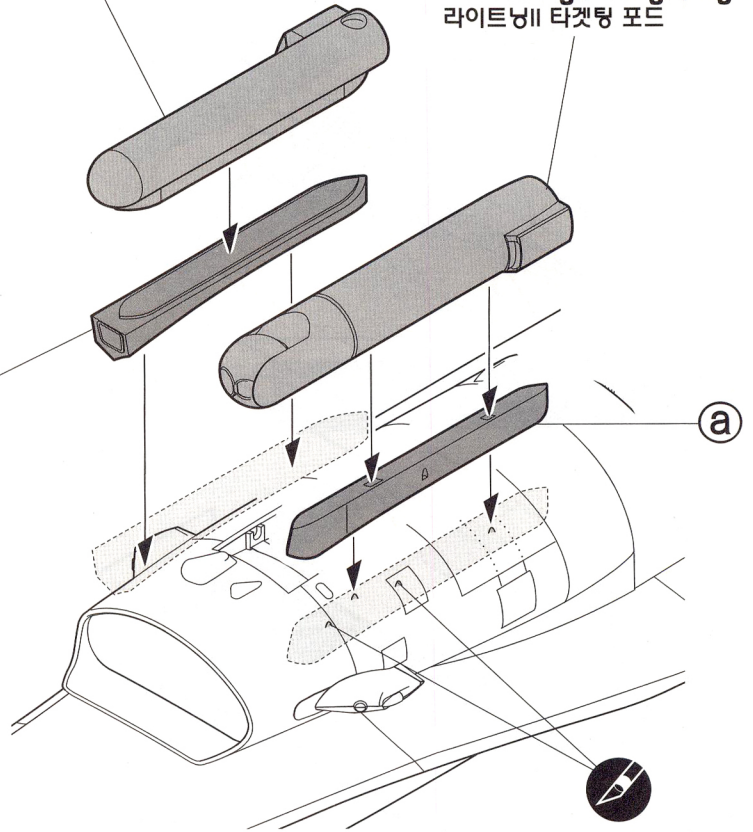

(b)

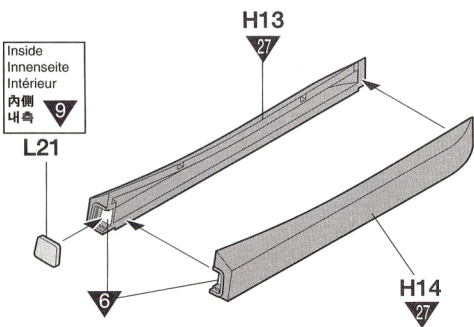

Inside  
Innenseite  
Intérieur  
内側  
내측

34



■ Pilot  
조종사

2

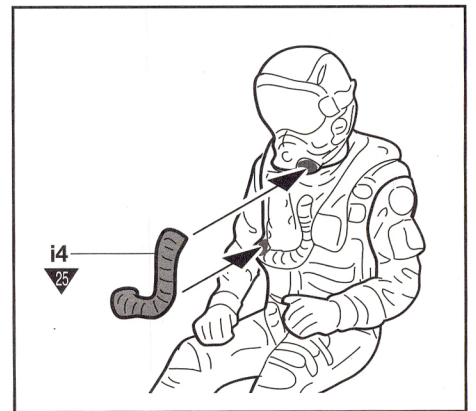
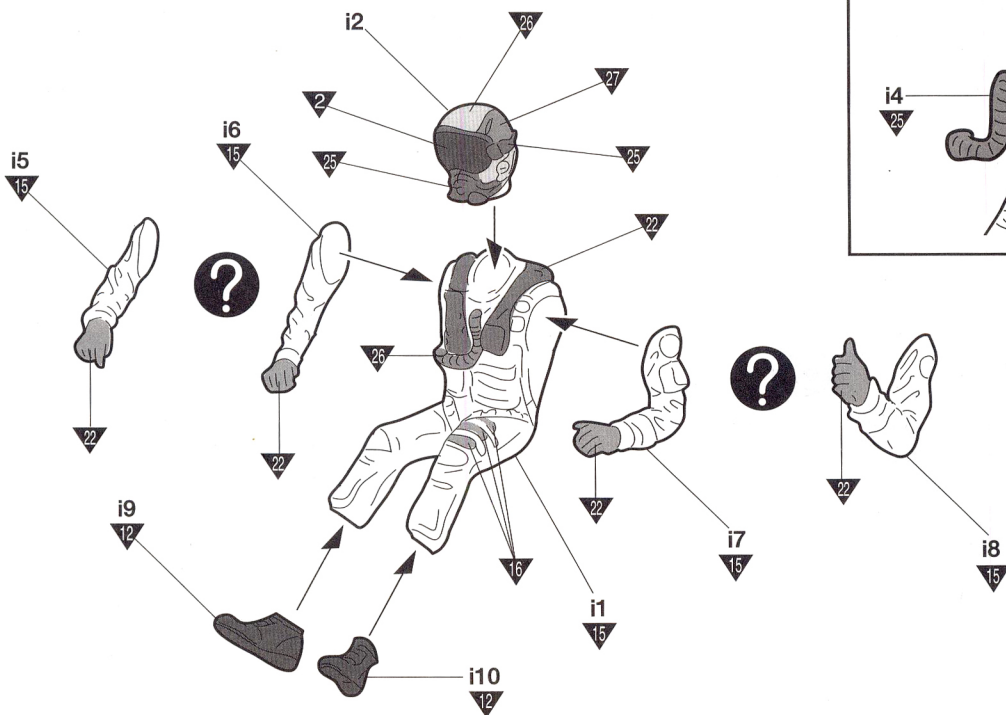

COMMON DATA  
공통 기본 데이터

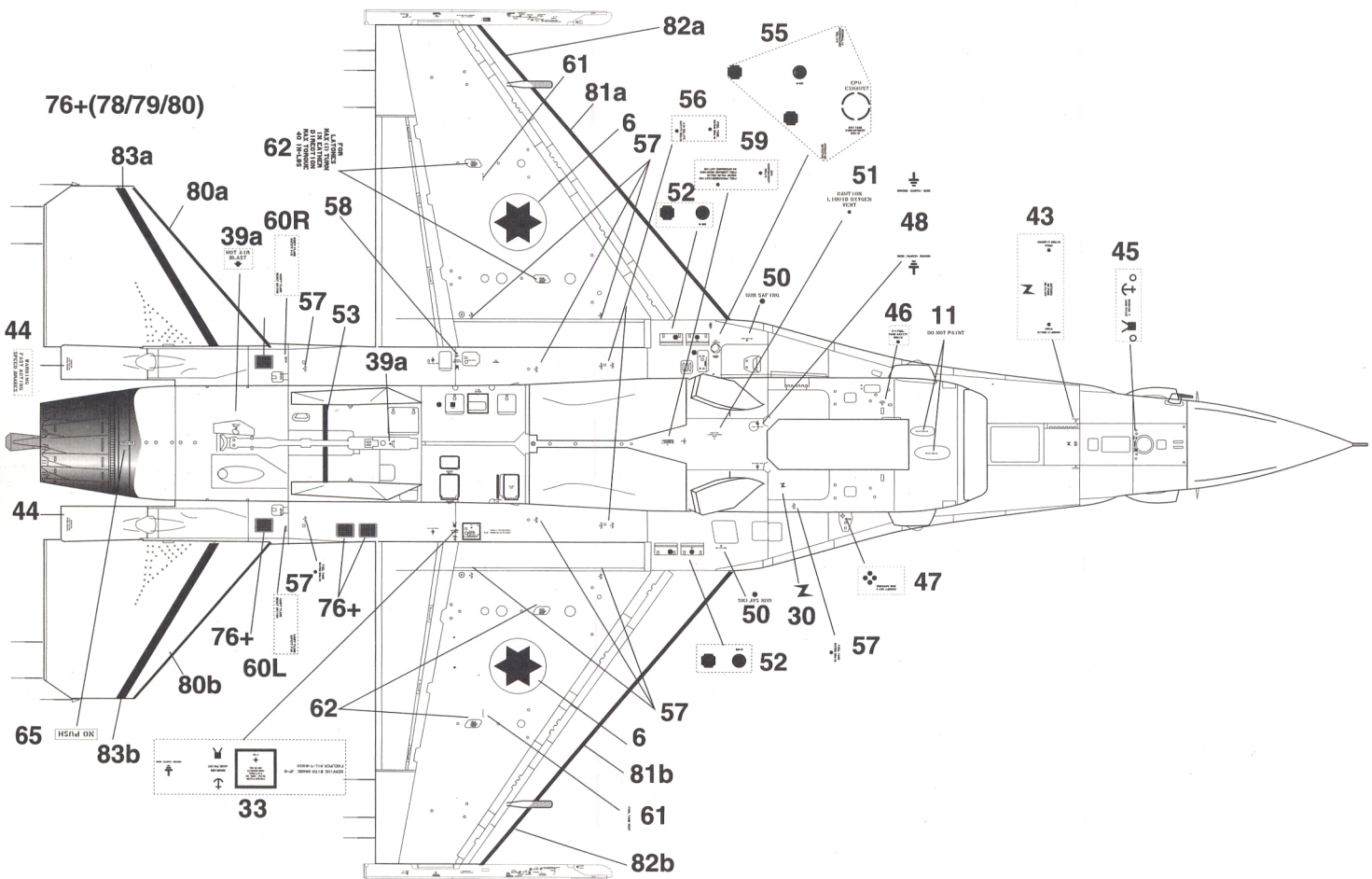
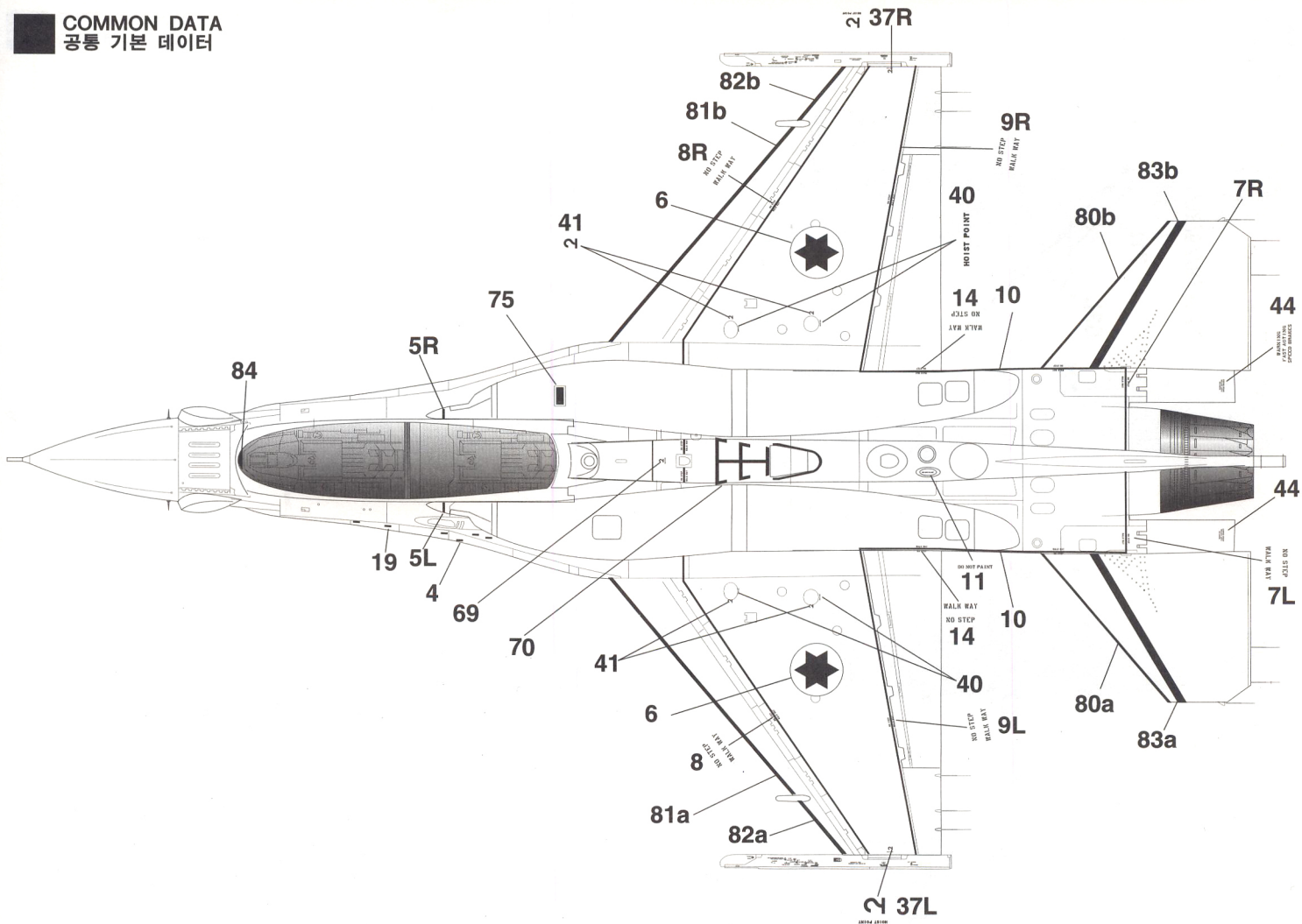



## FUEL TANK/PYLON DATA

\*COLOR 26

연료 탱크/파일런 데이터

300 Gal C/L Tank

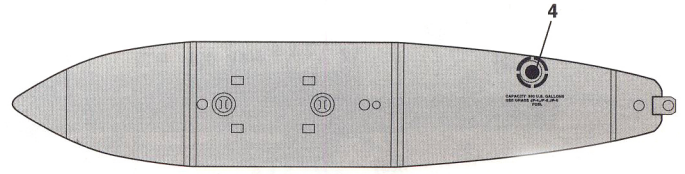
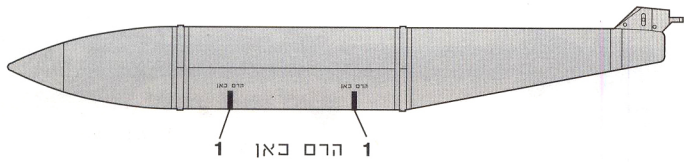

370 Gal Wing Tank

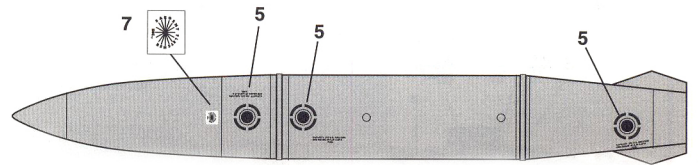
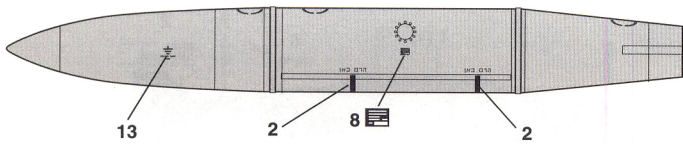

600 Gal Wing Tank

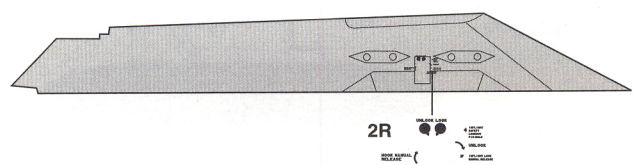
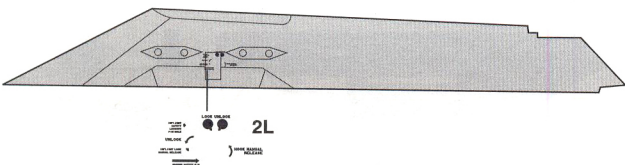
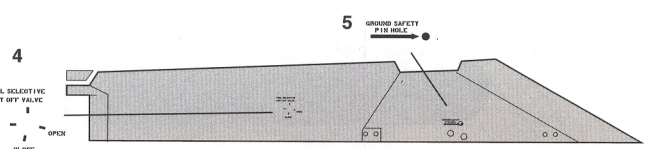
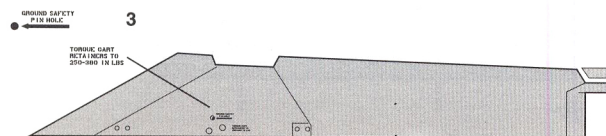
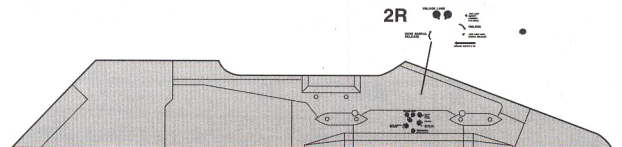
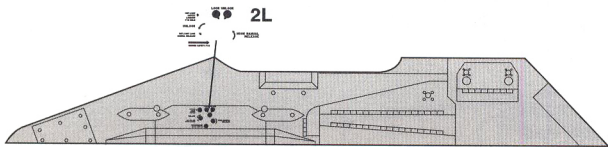
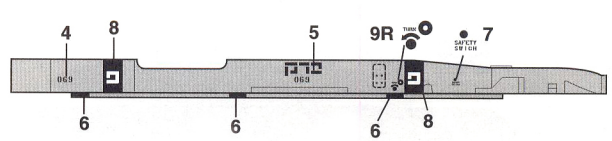
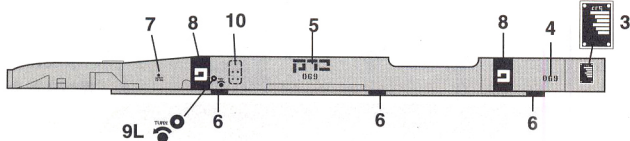
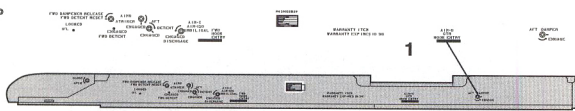
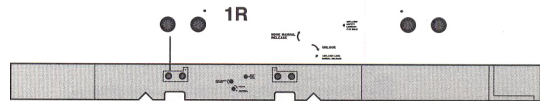
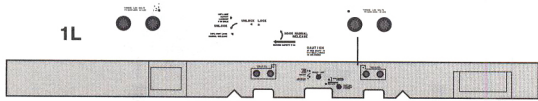
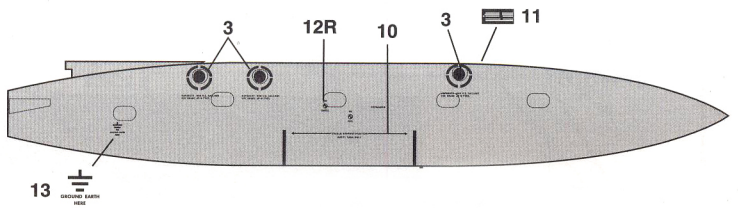
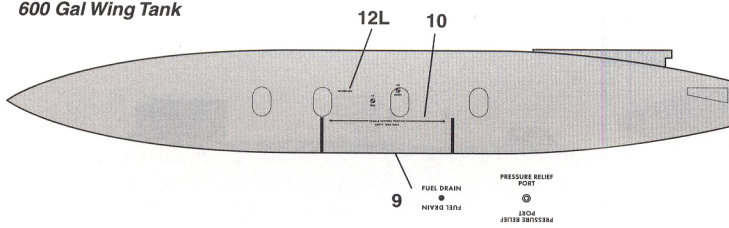

## ARMAMENT DATA 무장 데이터

\* ( ) is opposite number.  
( )는 반대측 번호입니다.

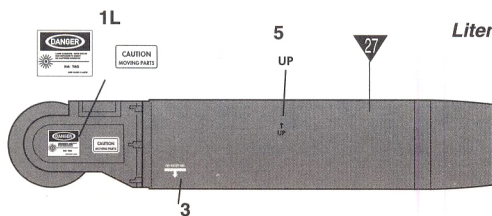
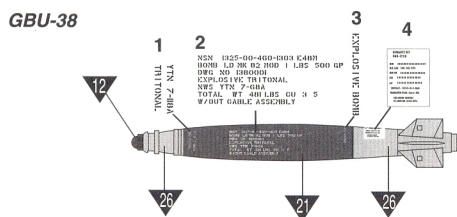
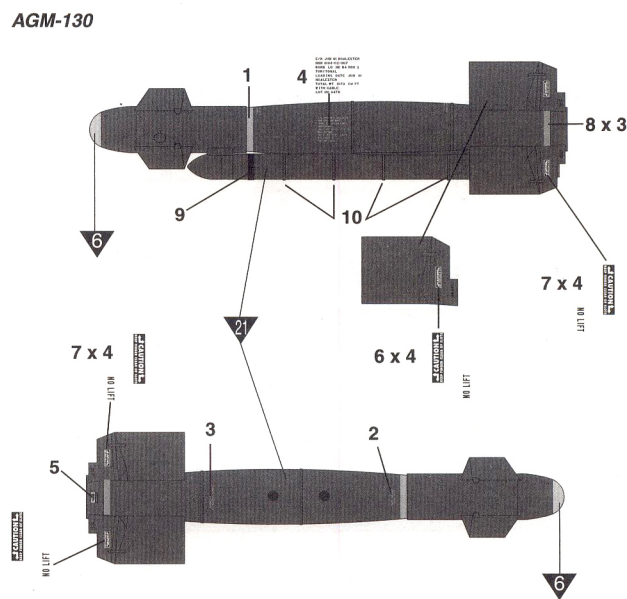
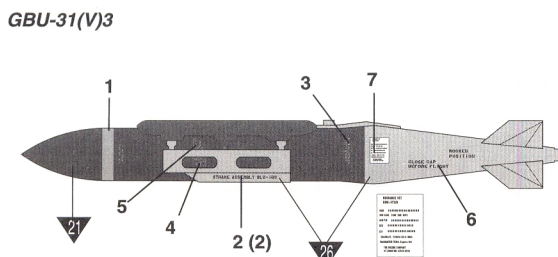
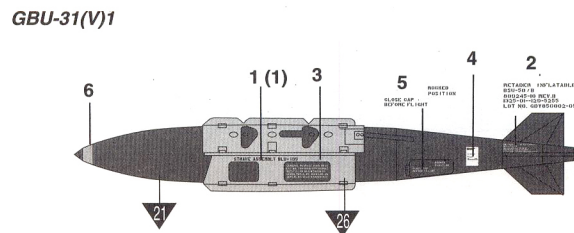
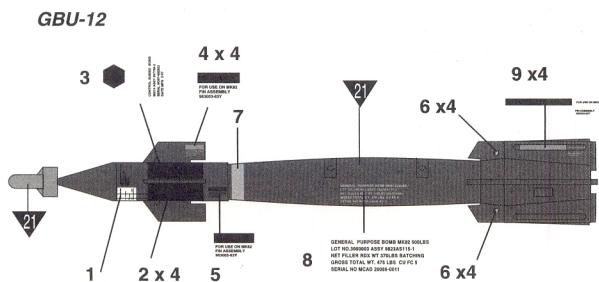
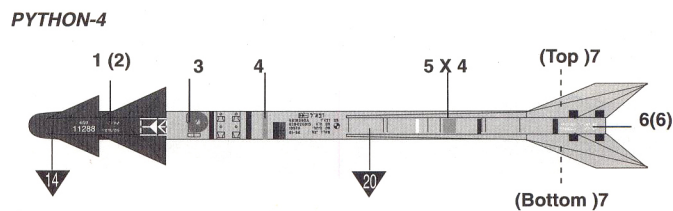
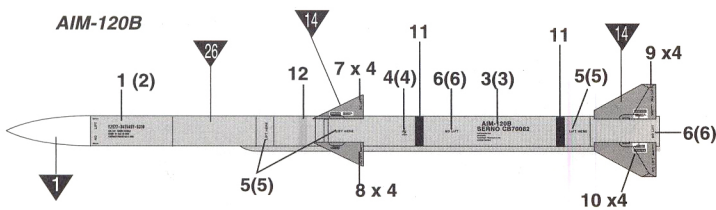

**Litening II Targeting Pod**

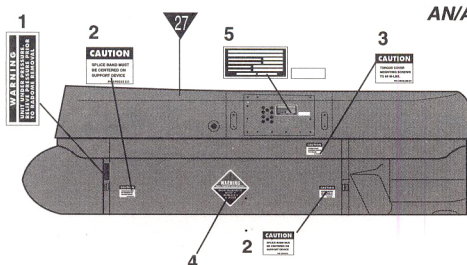
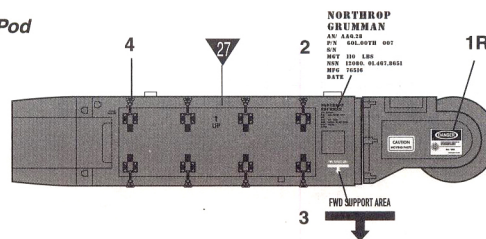
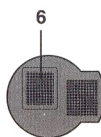

**AN/AAQ-13 Navigation Pod**

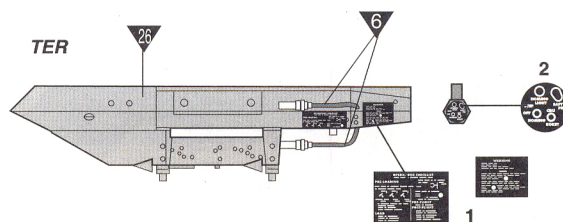
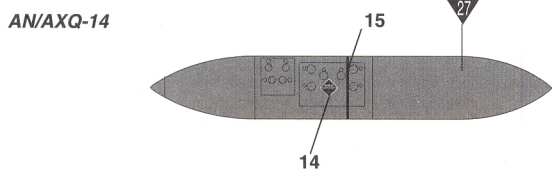
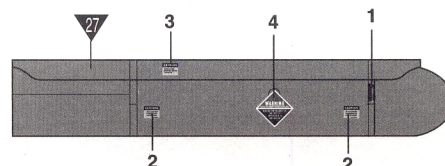
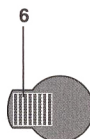

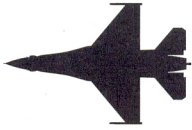

- ① LiteningII Targeting Pod
- ② AN/AAQ-13 LANTIRN Navigation Pod
- ③ 600 gal. Wing Fuel Tank
- ④ AGM-130
- ⑤ PYTHON-4
- ⑥ AIM-120B
- ⑦ AN/AXQ-14

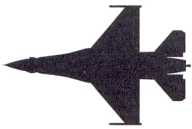
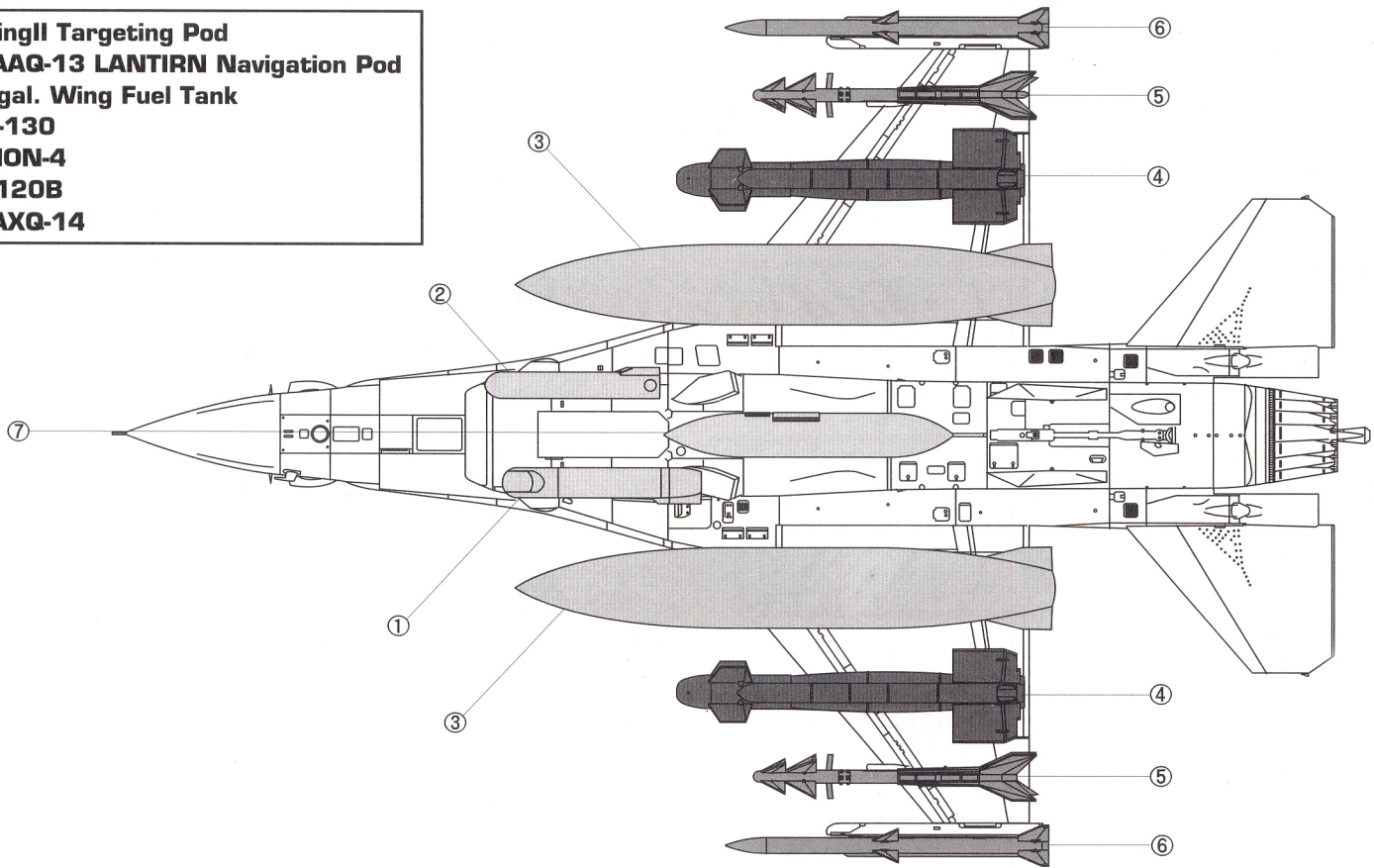

- ① LiteningII Targeting Pod
- ② AN/AAQ-13 LANTIRN Navigation Pod
- ③ 600 gal. Wing Fuel Tank
- ④ GBU-31(V)3 JDAM
- ⑤ PYTHON-4
- ⑥ AIM-120B
- ⑦ 300 gal. Center Line Fuel Tank

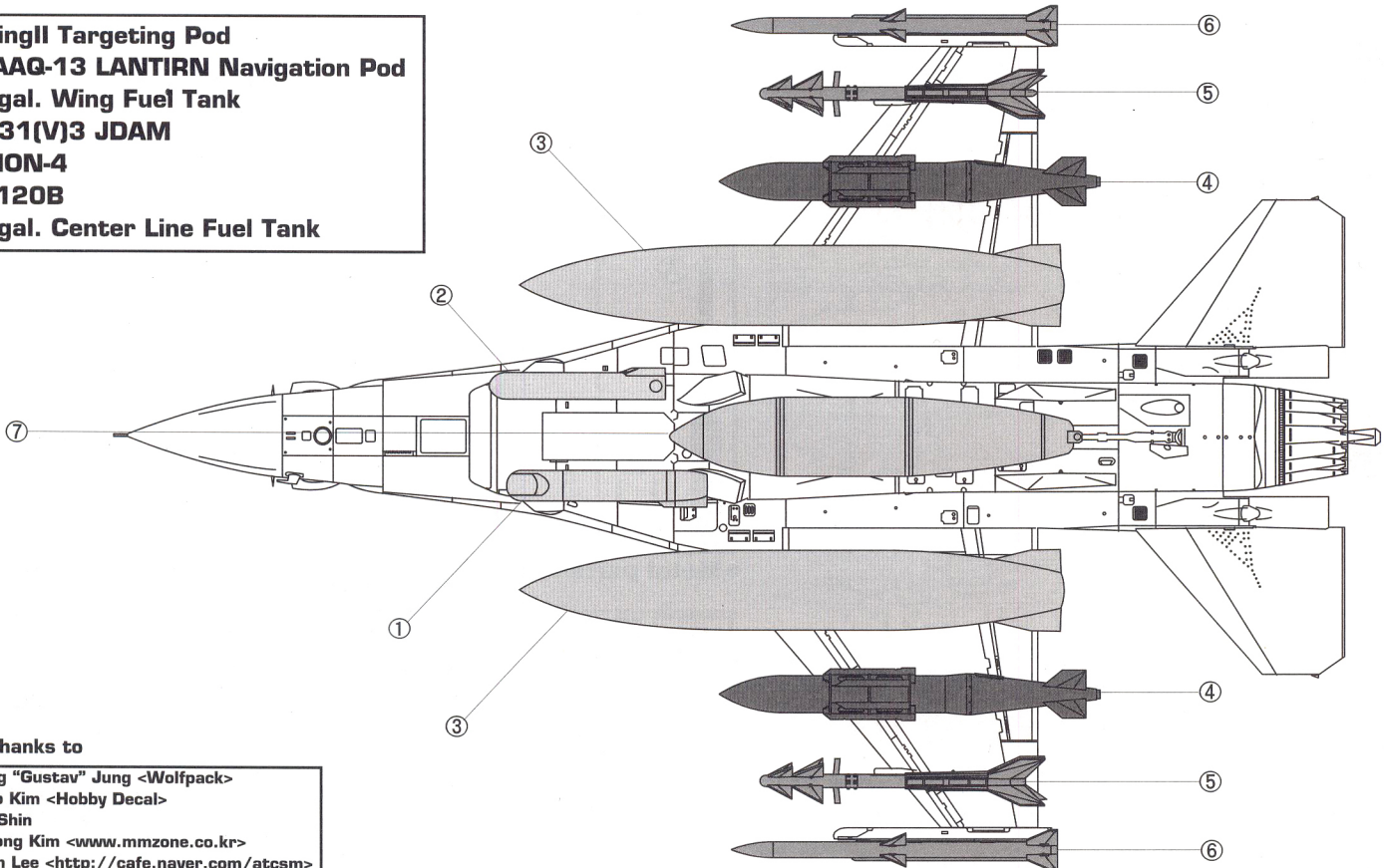

● Special thanks to

Mr. Ki-young "Gustav" Jung <Wolfpack>  
 Mr. Keun-ho Kim <Hobby Decal>  
 Mr. Jae-ho Shin  
 Mr. Sung-Jong Kim <www.mmzone.co.kr>  
 Mr. Ju-hwan Lee <http://cafe.naver.com/atcsm>

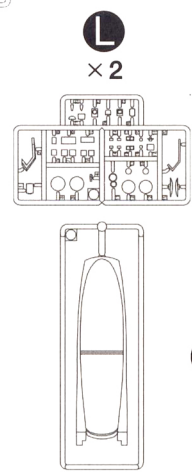
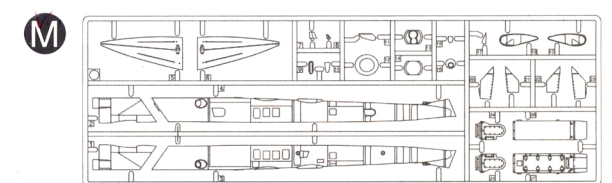
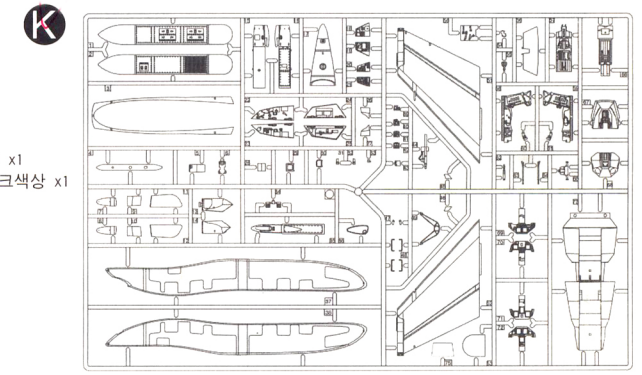
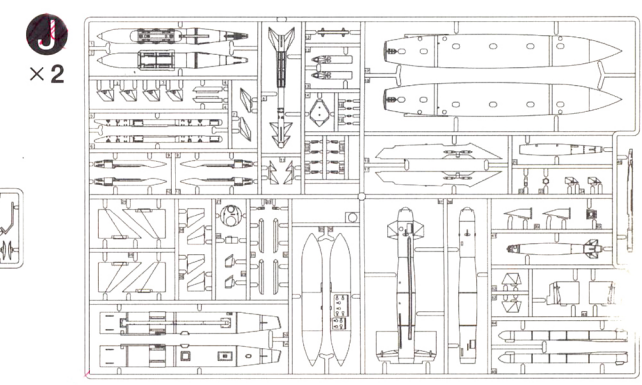
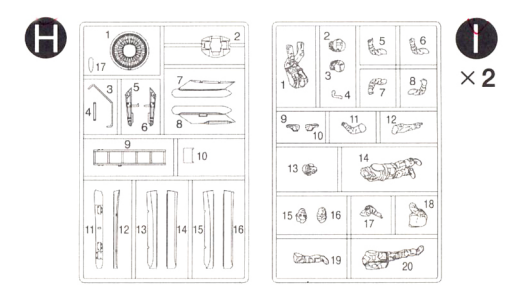
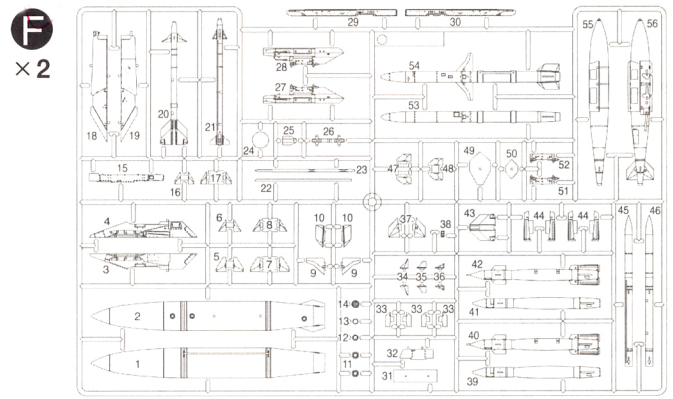
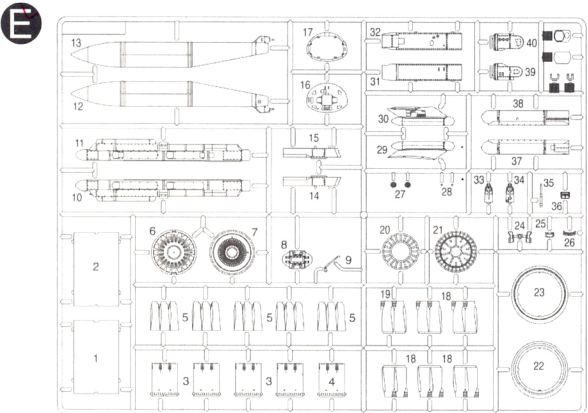
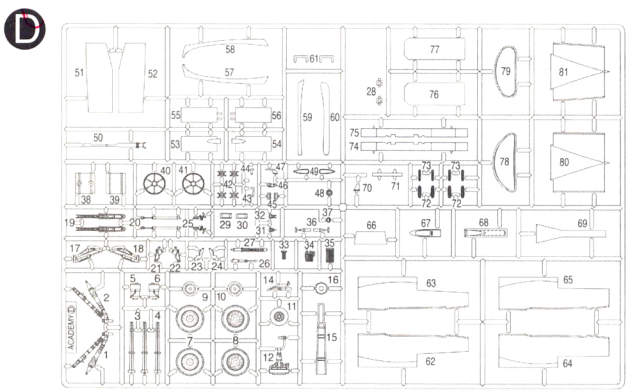
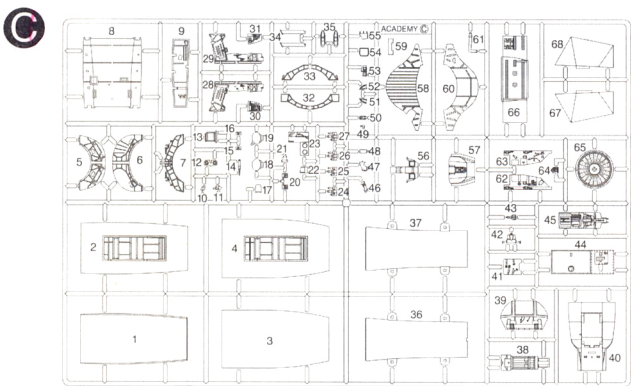
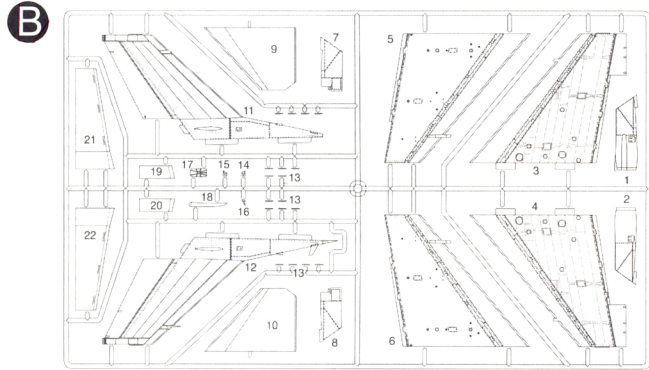
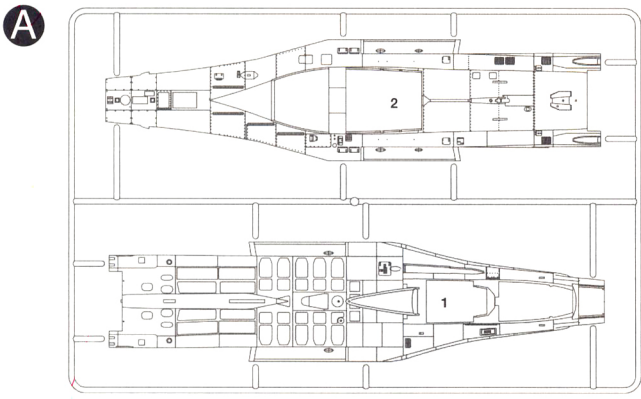

● Crystal Clear/투명 x1  
Smoke Color/스모크색상 x1

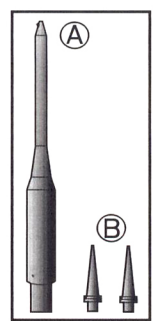

● Metal parts/메탈

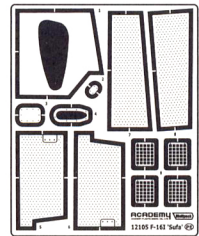

● Photo etched/에칭

● Decal/전사지

● Unused parts/불필요 부품  
B1, B2, B7, B8, B11, B12, B13X3, B14, B15, B17, B18, C3, C4, C15, C16, C22, C23, C30, C31, C34X1, C35, C39, C40, C44, C46, C49, C50, C51, C52, C53, C54, C55, C56, C57, C58, C60, C61, C62, C63, C64, C66, D3, D4, D5, D6, D15, D16, D33, D34, D35, D37, D38, D39, D40, D41, D48, D49, D57, D58, D59, D60, D61, D64, D65, D66, D67, D68, D73, D76, D78, D80, E6, E10, E11, E14, E15, E18, E19, E20, E23, E26, E27X1, E29, E30, E31, E32, E36, E39, E40, E43, E44, F9X2, F10X2, F12X2, F13X2, F15X2, F16X2, F17X2, F20X2, F21X2, F23X2, F25X2, F30X2, F31X2, F34X2, F35X2, F36X2, F38X2, F43X2, F47X2, F48X2, F53X2, F54X2, H1, H7, H8, H15, H16, H17, I3X2, I11X2, I12X2, I13X2, I14X2, I15X2, I16X2, I17X2, I18X2, I19X2, I20X2, J5X2, J6X2, J9X2, J10X2, J13X2, J15X2, J16X2, J25X2, J26X2, J27X2, J28X2, J29X2, J31X2, J32X2, J33X2, J34X2, J35X1, J36X1, K1, K2, K4, K6, K13, K14, K15, K16, K17, K30, K39, K42, K71, K72, L2, L5, L6, L7, L8, L12, L19, L20, L21X1, L24, L25, L26