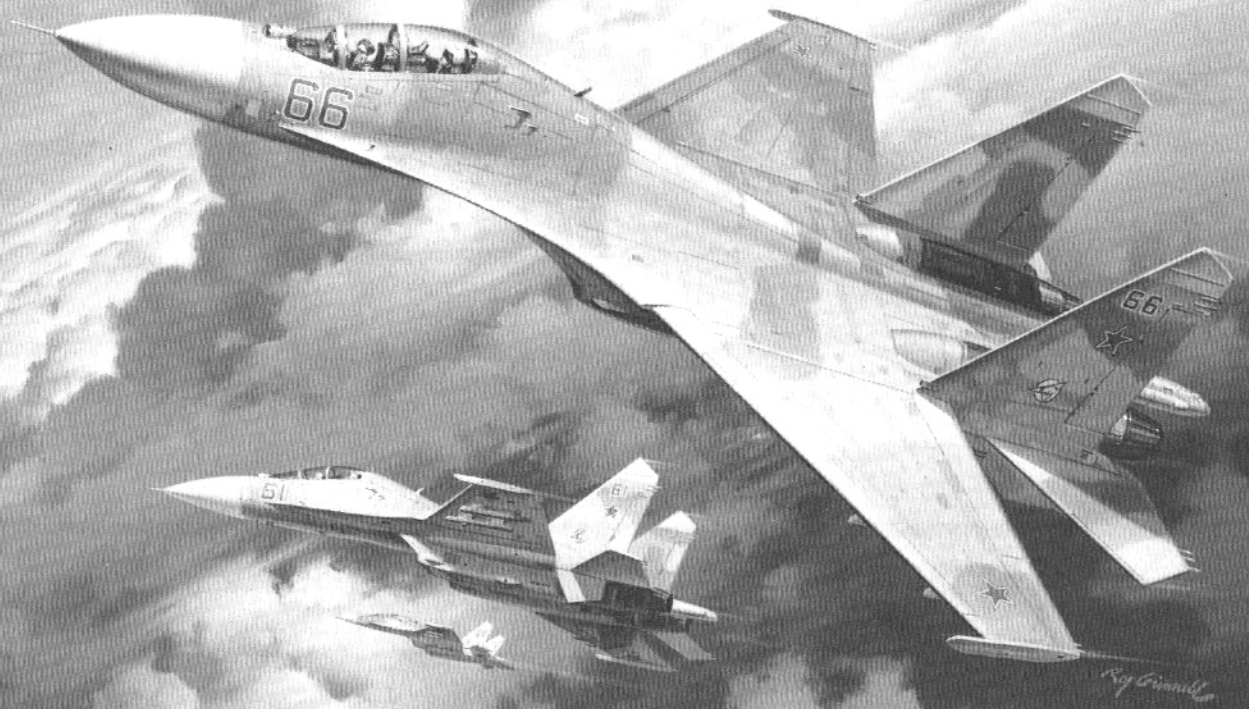

**ACADEMY**

HOBBY MODEL KITS

**1/48th Scale**

# SUKHOI SU-27UB FLANKER C

When the SU-27 performed its "Cobra", maneuver at the 1989 Paris Air Show, the western world suddenly learned that the SU-27 design was very probably the finest fighter plane in the world. To see this very large airplane fly at an attack angle of 120 degrees without crashing, shocked every observer. Since then the routine has been performed as a demonstration feature at most air shows.

From 1977, when the prototype T-10 was spotted by satellite, until 1988, few hard facts and little information were available. It was thought that this twin-engined fighter plane had strong design resemblances to parts of the F-14, F-15 and F-18.

Between October 1986 and December 1988 a specially modified prototype T-10, known as the P-42 was used to establish 27 performance records which were submitted to the FIA for certification. All the records previously established by the F-15 Strike Eagle were wiped out by the P-42. When this information was published, it became general knowledge that this was an aircraft to be considered most seriously.

Some analyst think that the Russian avionics and weapons systems are not quite equal to the western competition, but in terms of speed, range and maneuverability, the SU-27 is superior to any aircraft in the western inventory. Probably until such time that the Lockheed F-22 is operational, the SU-27 must be regarded as the best fighter in the world.

Much of the SU-27's performance must be credited to its superb AL-31F engines which are rated at 12,500Kg(27,550lb) thrust in after-burner stage. The engines which are easy to maintain and interchangeable between left and right, have a tremendous tolerance to severaly disturbed air flow. It is this feature that allows the engines to run smoothly while the Flanker performs these unusual maneuvers. Unlike earlier short-lived Soviet jet engines, the AL-31F engines have a life of 3,000 hours based on 100 hour engine checks and 1,000 hour overhauls. This is fully comparable to the best the west can offer.

Armed with four R-73 AA-73 Archer missiles for short range combat and an array of R-27 IR-homing long range missiles, the SU-27 also carries the same internal GSh-30-1 30mm cannon used by the MIG-29, Firing at a rate of 1,500 rounds per minute, the cannon barrels only have a life expectancy of 80 seconds before they must be replaced.

**The SU-27 Flanker**, together with the MIG-29 give Russia air combat capability that is certainly equal to but most likely superior to that presently available to the west.



Cement Parts  
Coller  
Kleben  
Pegar  
Incollare  
Cola r  
Kleven



DO NOT cement  
Ne pas coller  
Nicht kleben  
No pegar  
Non incollare  
Nao colar  
Niet kleven



Cut away  
Couper  
Scheiden  
Cortar  
Tagliare  
Cortar  
Snijden



Optional parts  
Choix  
Auswahlmoglichkeit  
Eleccion  
Scelta  
Opcao  
Keuze



**3**

Repeat operation  
Repéter l'opération  
Vorgang wiederholen  
Repitir la operacion  
Ripetere  
Repitir a operacão  
Herhalen

# 1 LOWER FUSELAGE HALF PREPARATION

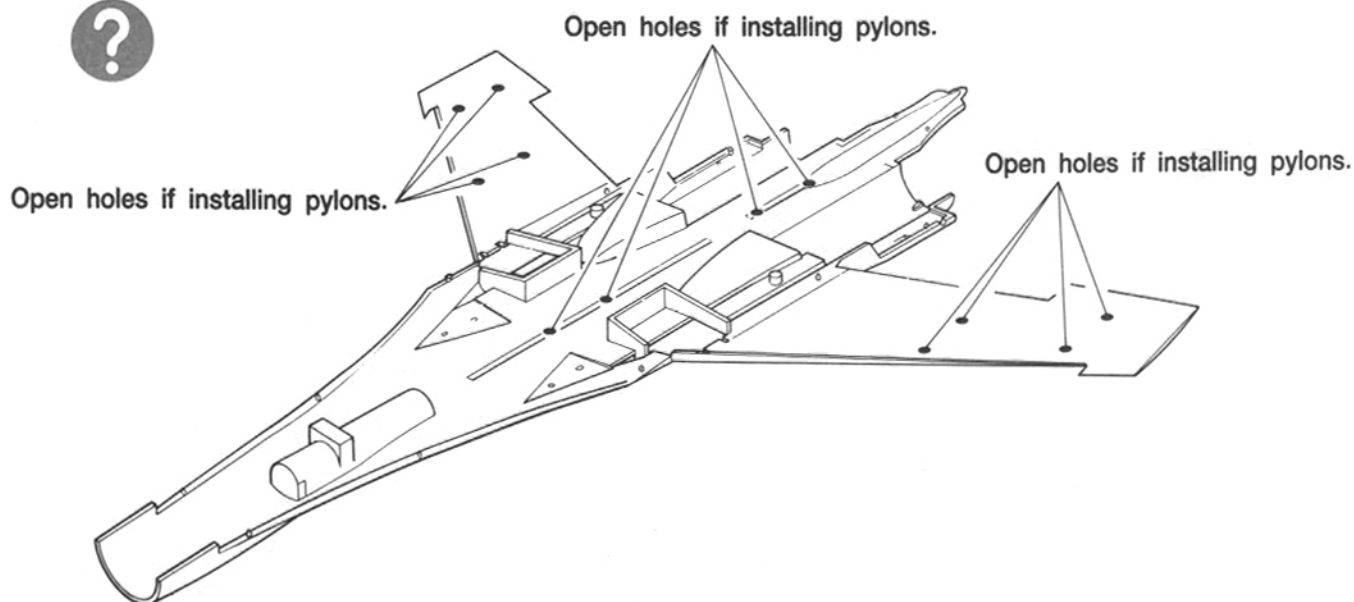

# 2 FAN BLADE INSTALLATION

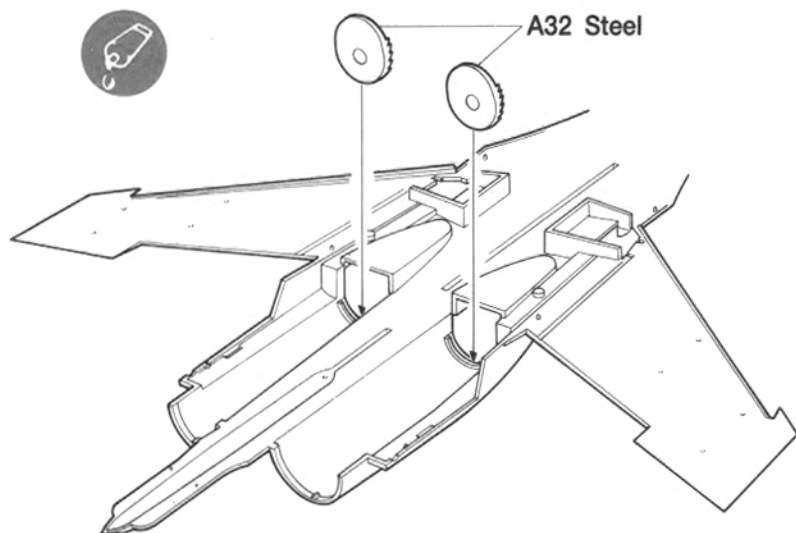

# 3 UPPER FUSELAGE HALF PREPARATION

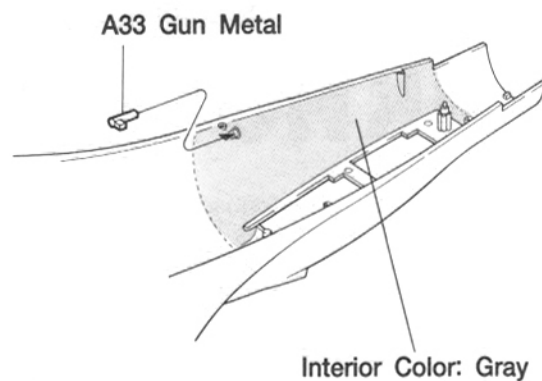

# 4 COCKPIT ASSEMBLY

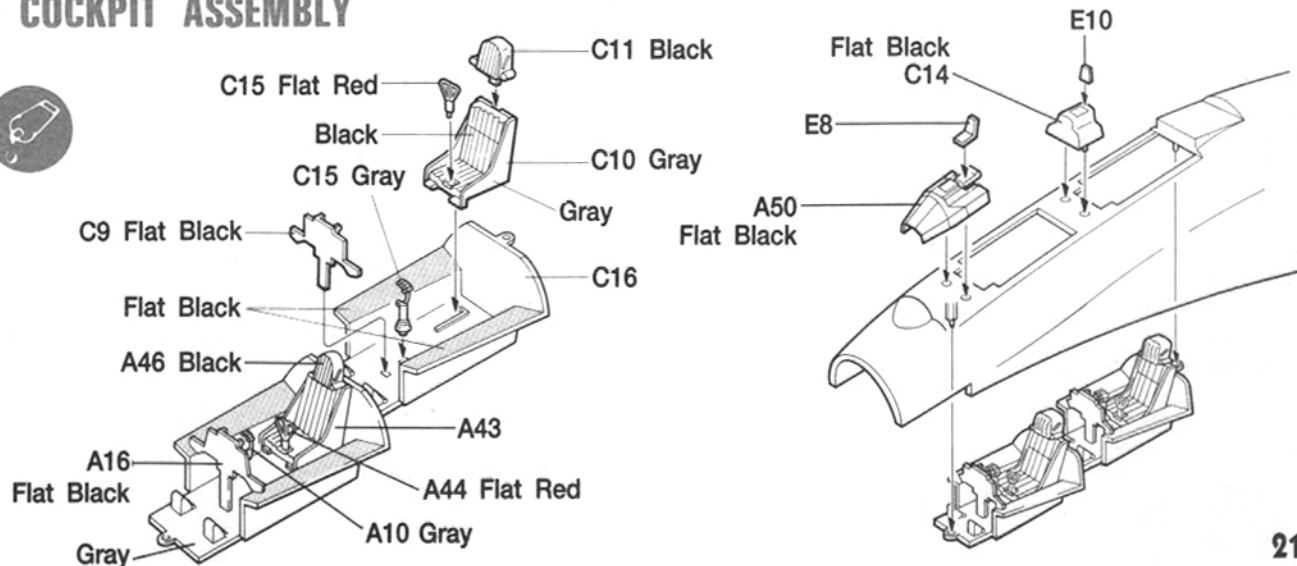

## 5 FUSELAGE HALVES ASSEMBLY

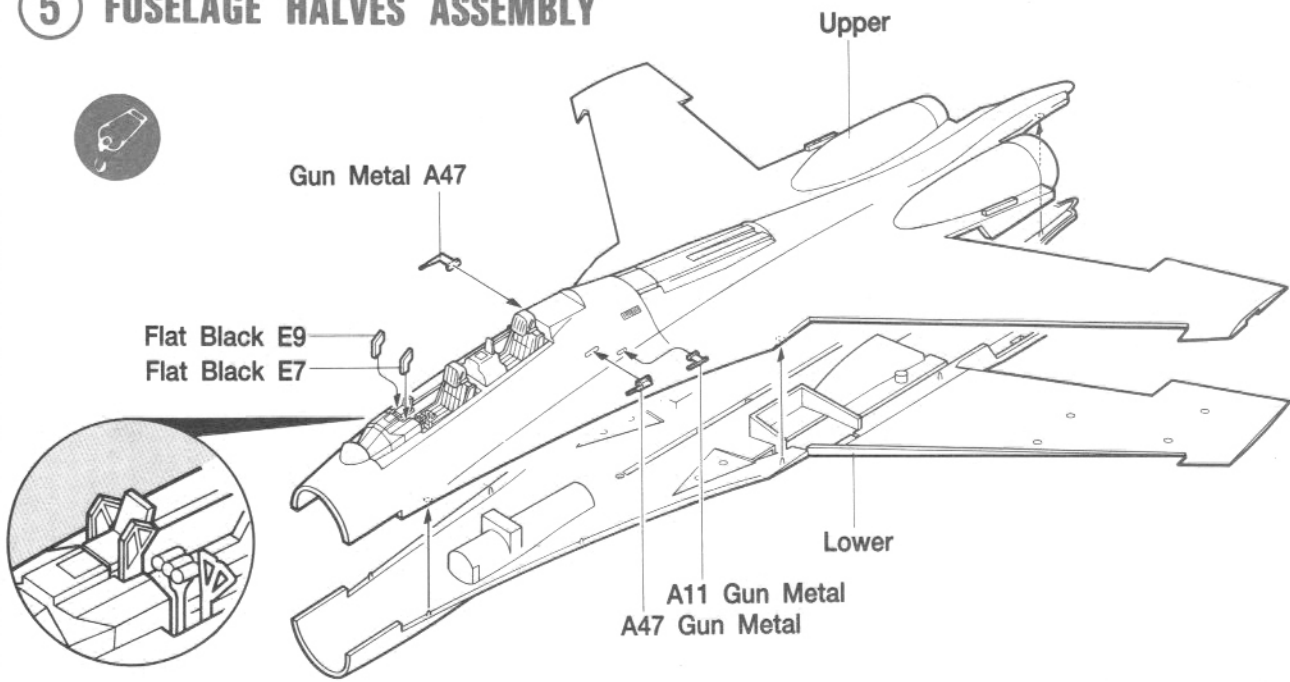

## 6 AIR INTAKE ASSEMBLY

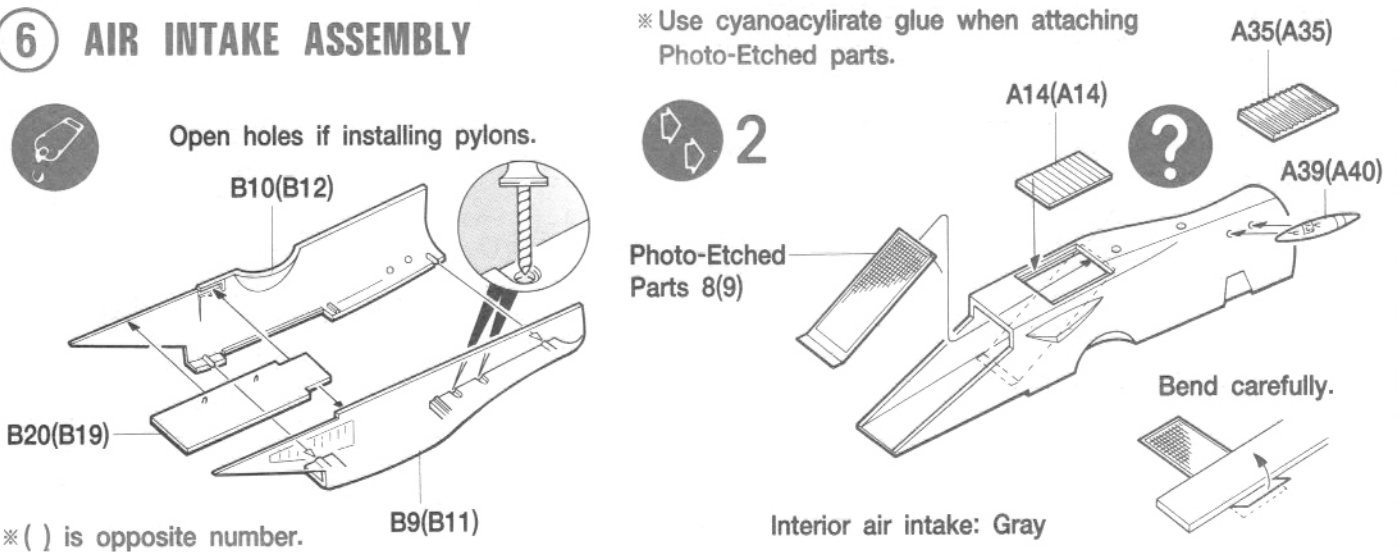

## 7 LOWER FUSELAGE COMPONENTS INSTALLATION

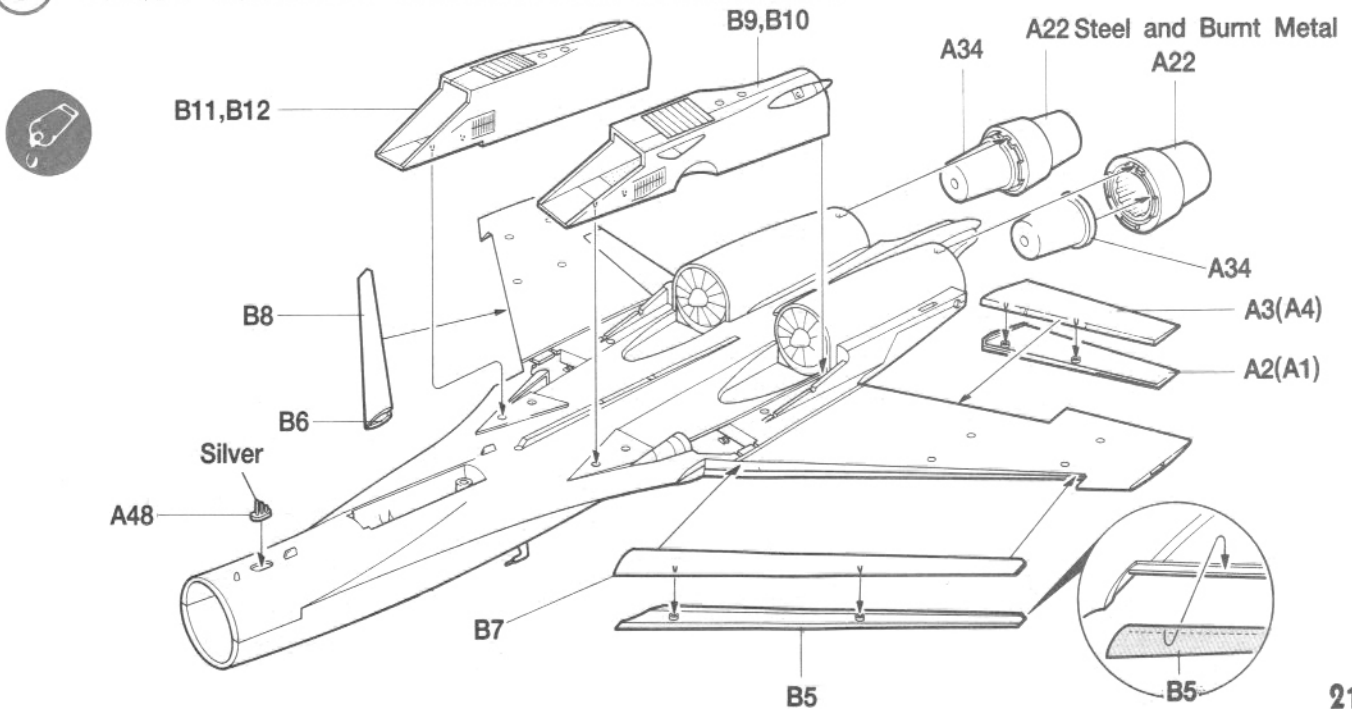

# 8 LANDING GEAR ASSEMBLY

Wheel hubs: Dark Green



P.V.C. Tire(Small)

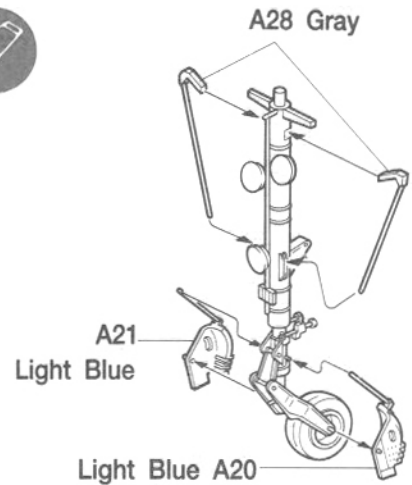
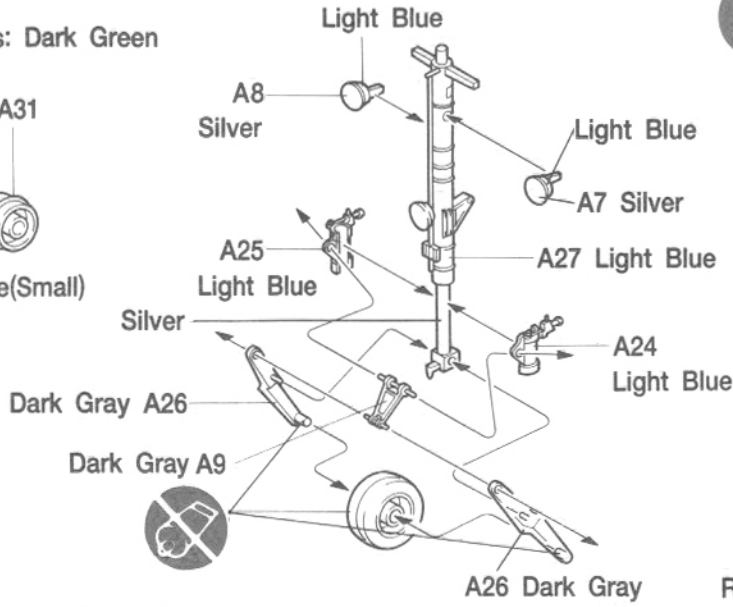

Remove the useless portions.

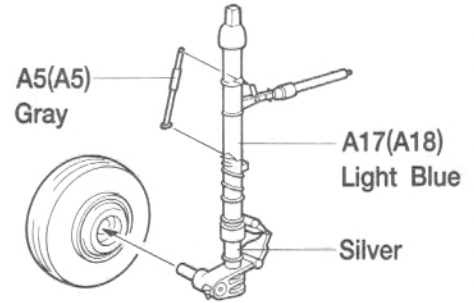
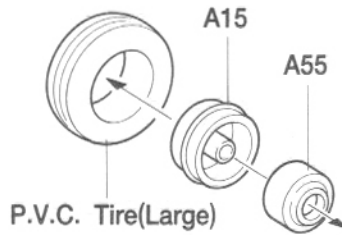
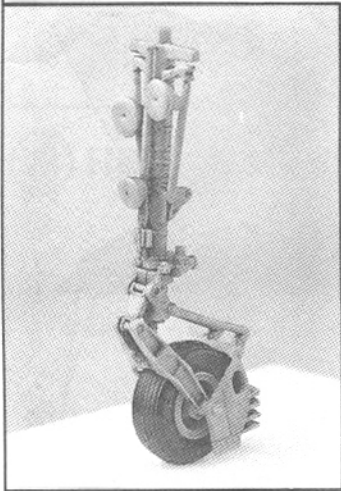
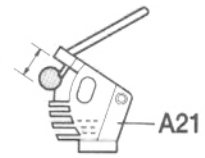

# 9 LANDING GEAR, DOOR AND FIN INSTALLATION

Interior landing gear wells: Gray

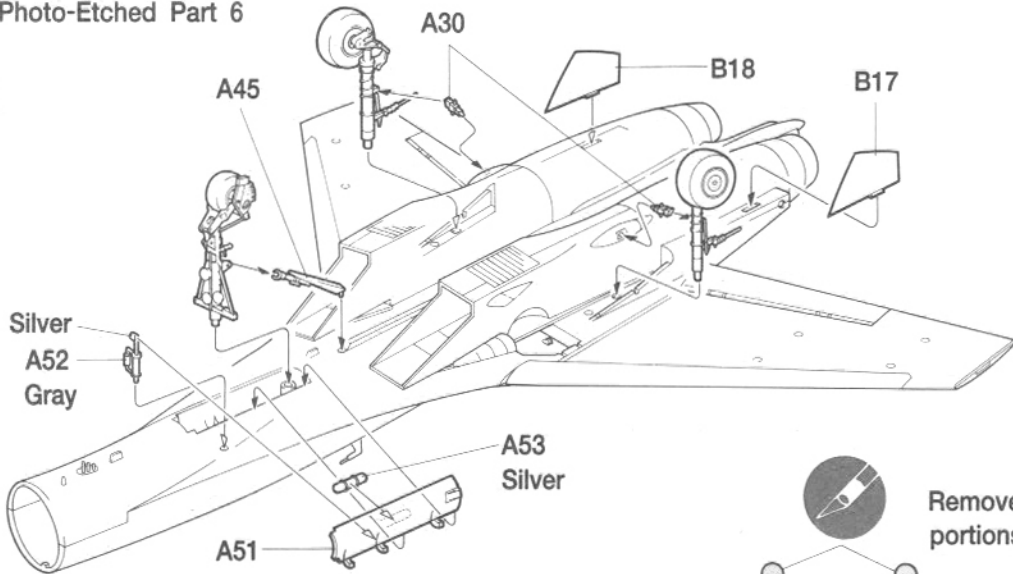
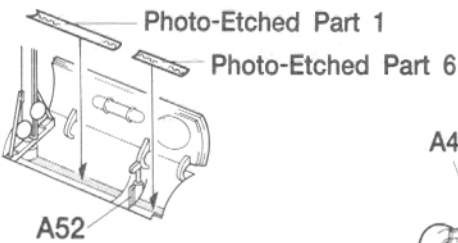

Remove the useless portions.

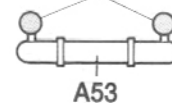

Inside door: Red

# 10 NOSE AND LANDING GEAR DOOR INSTALLATION

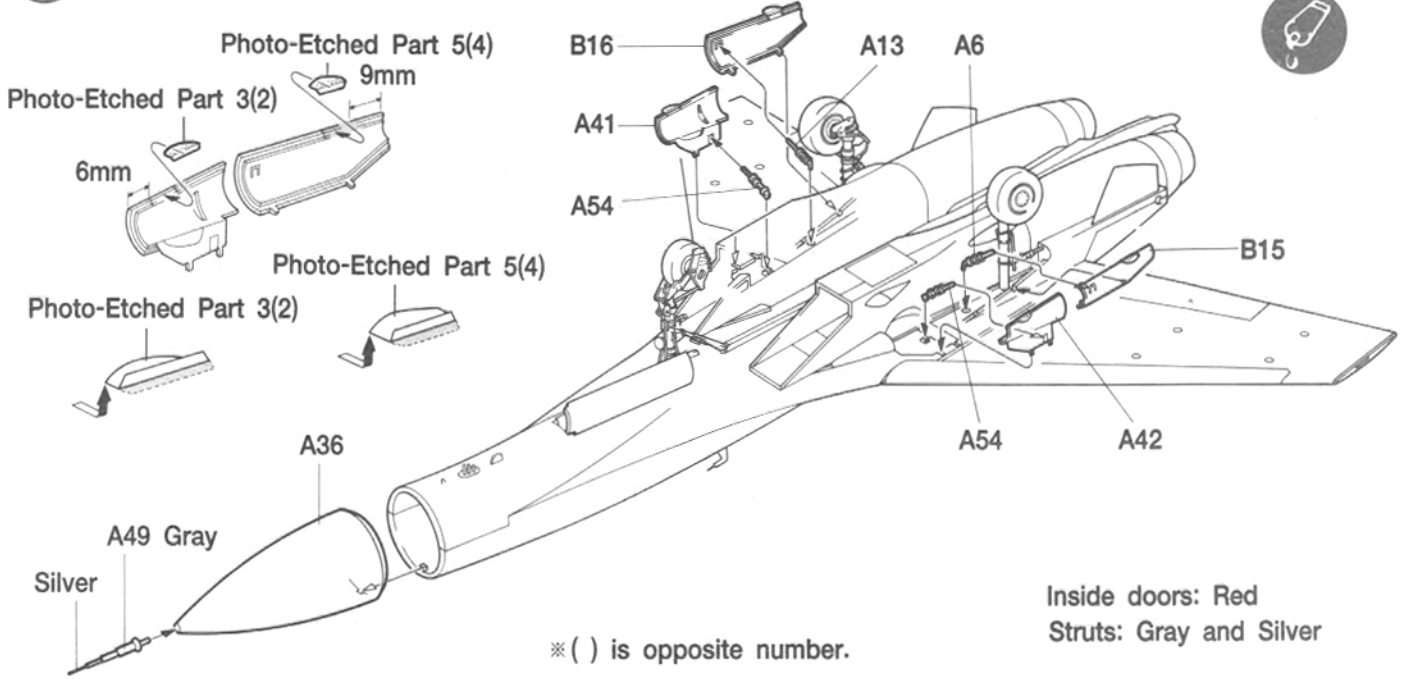

# 11 WEAPONS AND PYLONS ASSEMBLY

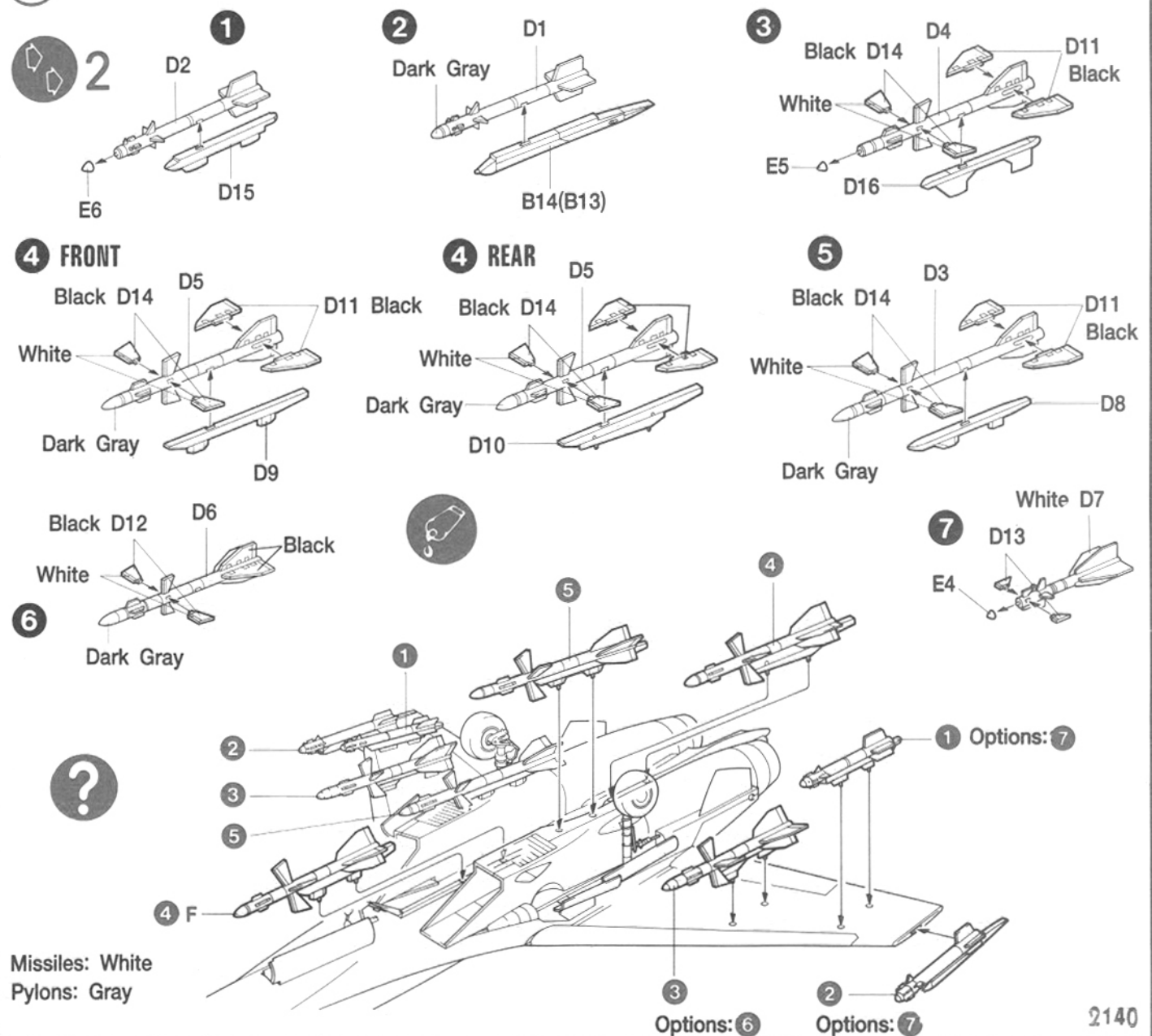

## 12 RUDDER AND ELEVATOR ASSEMBLY

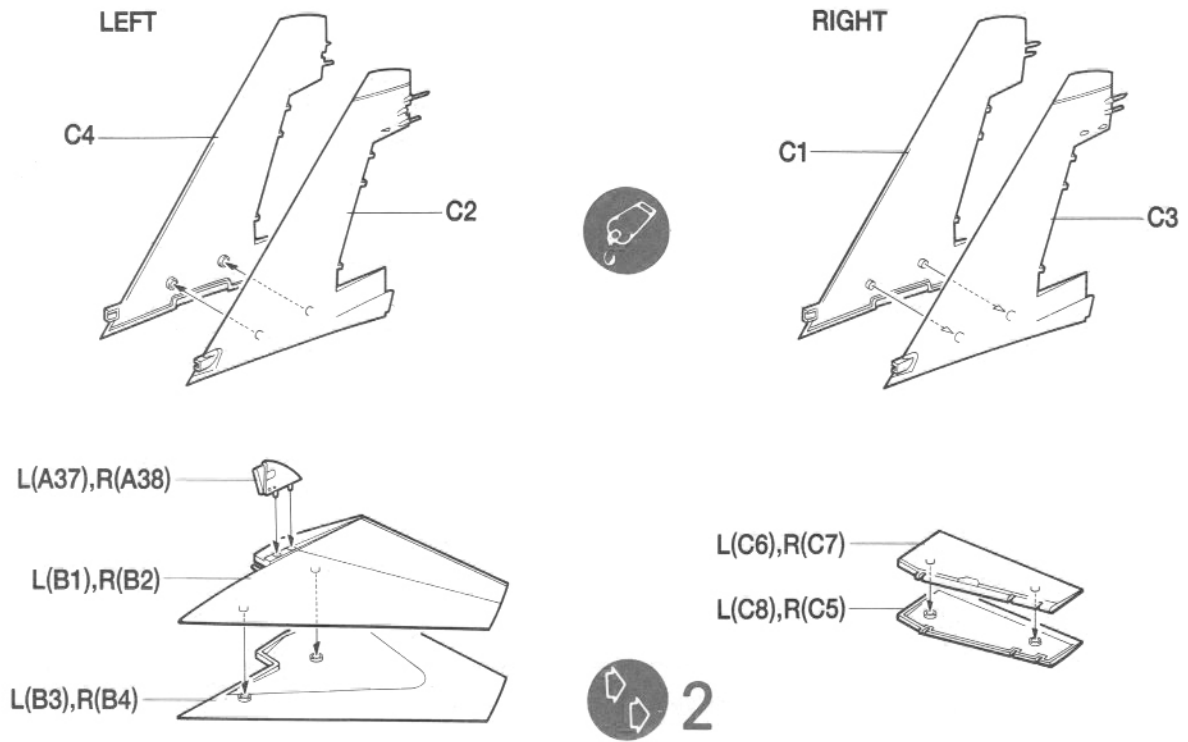

## 13 FINAL ASSEMBLY

Inside air brake: Yellow Green

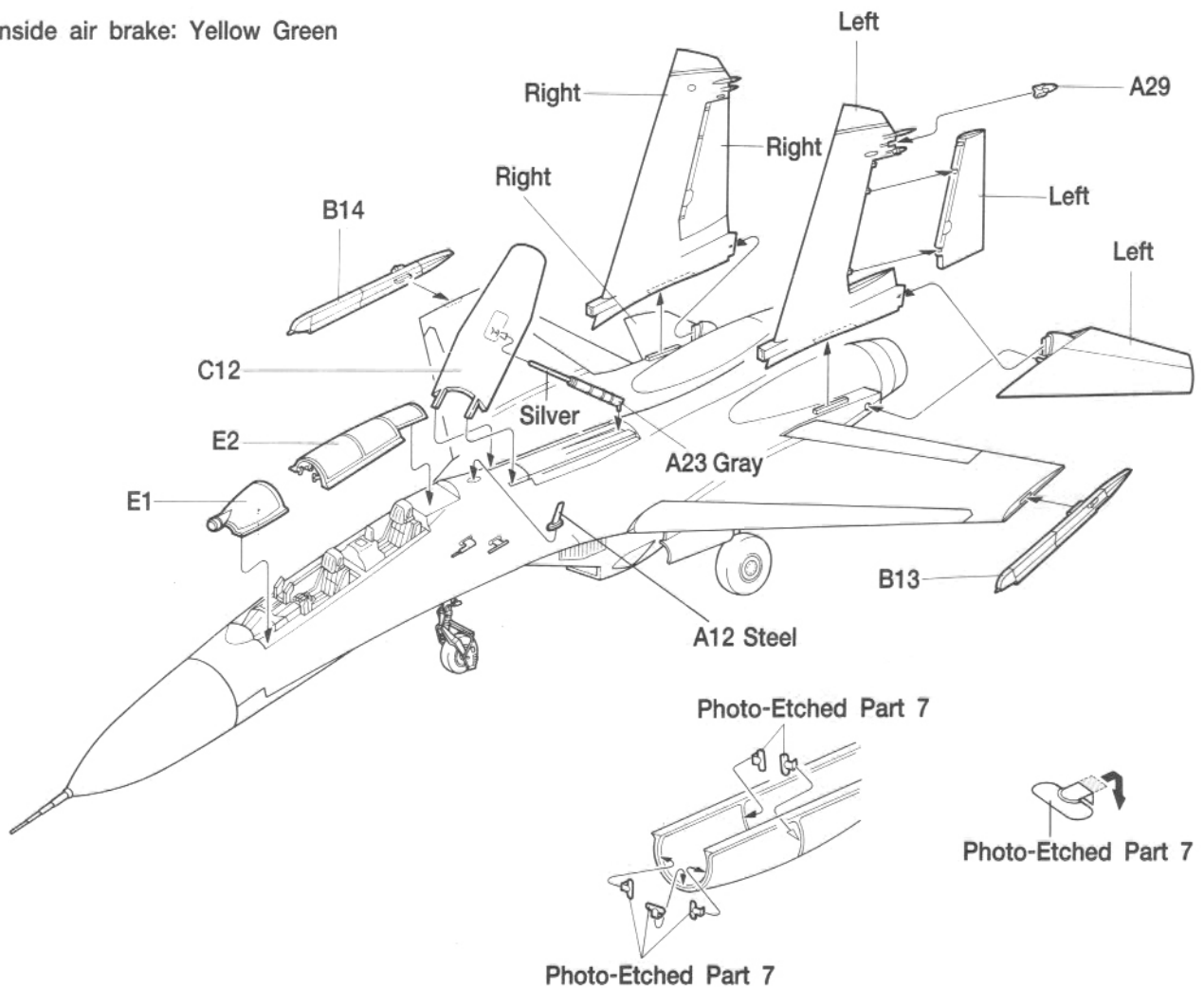

# PAINING AND DECAL PLACEMENT



WHITE F.S.17778



STEEL

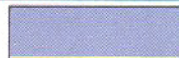

DARK BLUE F.S.25450  
NICHE NO. 7706



BLUE GRAY F.S.25526  
NICHE NO. 7707



LIGHT BLUE F.S.25550  
NICHE NO. 7708

## • RIGHT

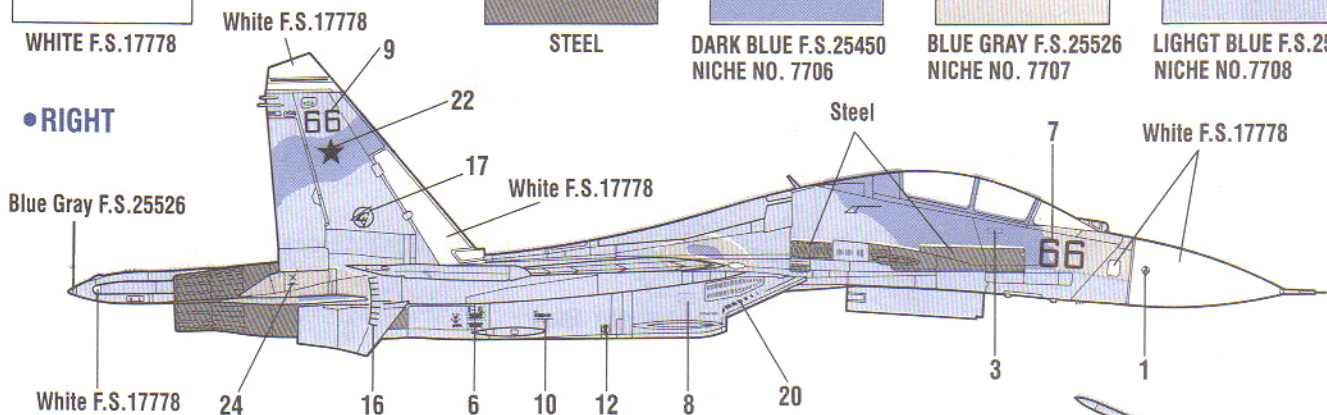

White F.S.17778

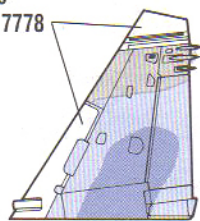

## • RIGHT INSIDE

## • UPPER

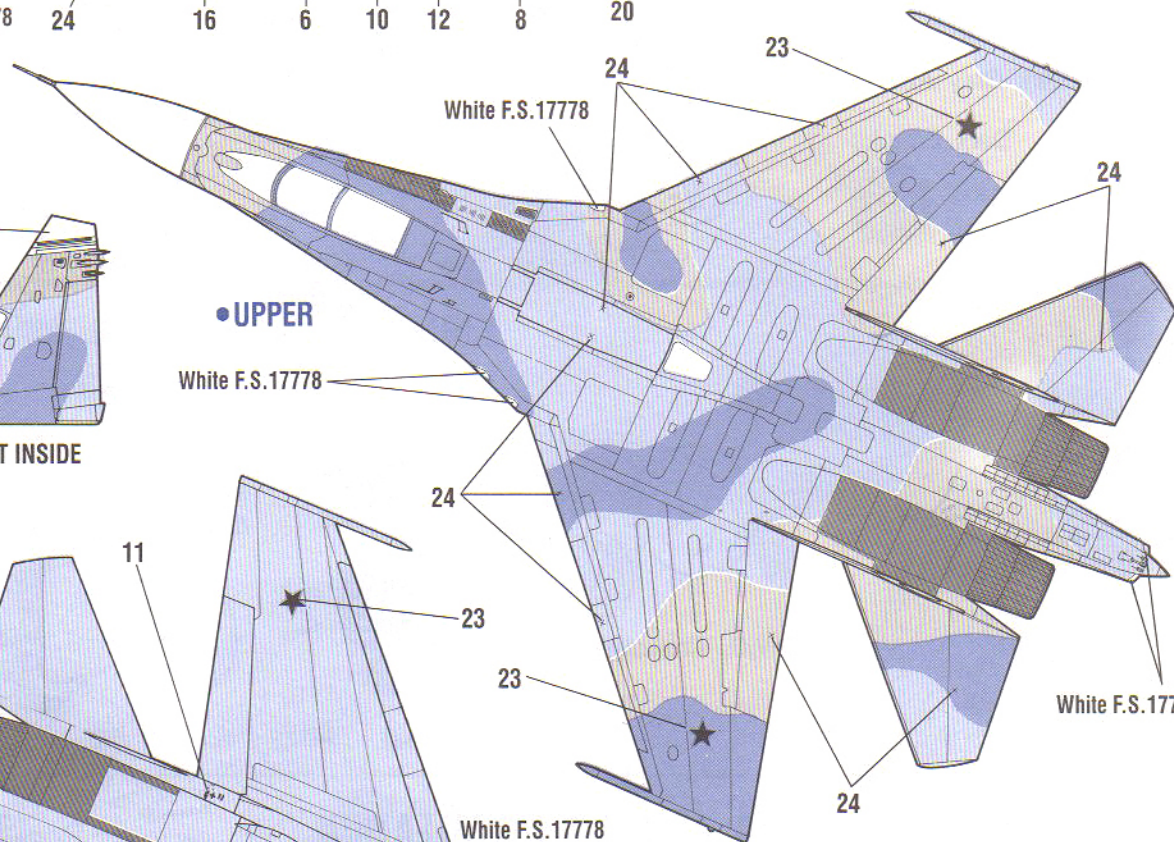

Steel & Burnt Metal

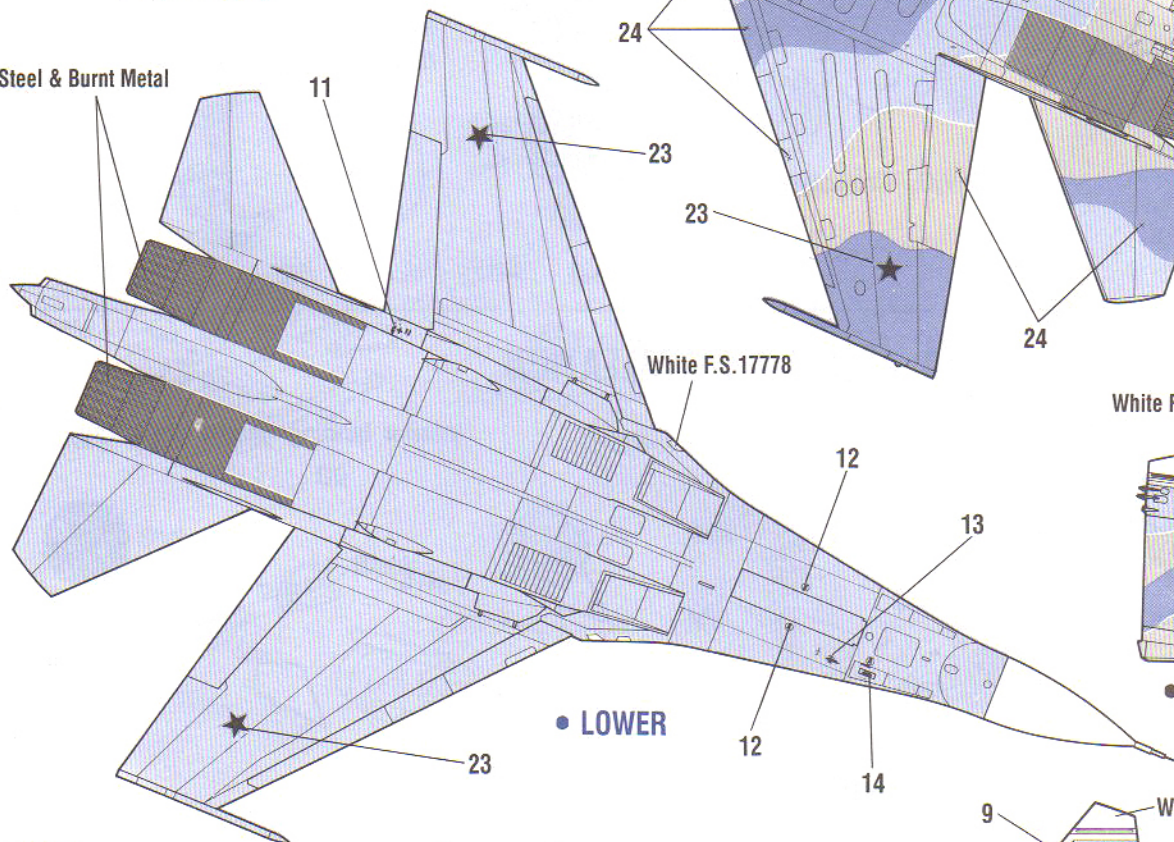

White F.S.17778

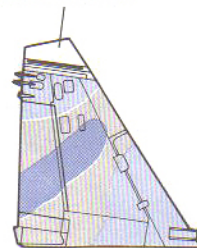

## • LEFT INSIDE

## • LEFT

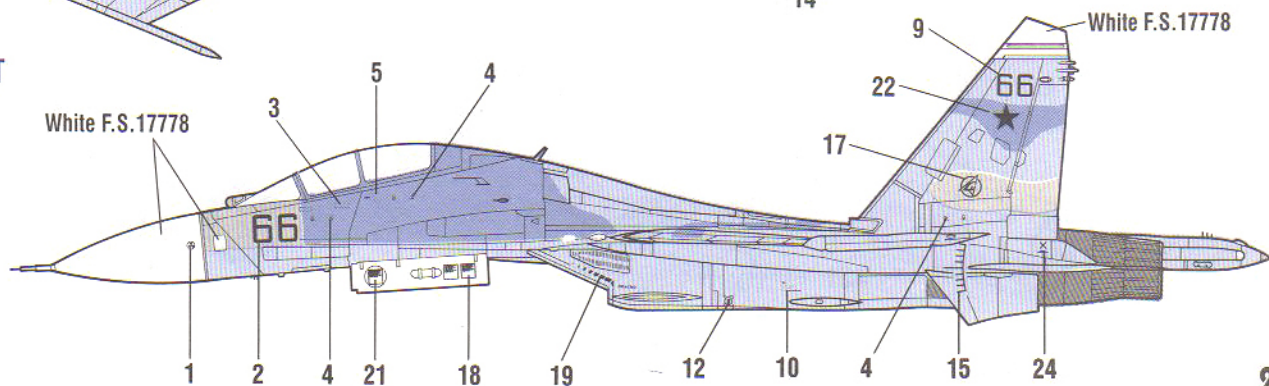

# PARTS LOCATING DIAGRAM

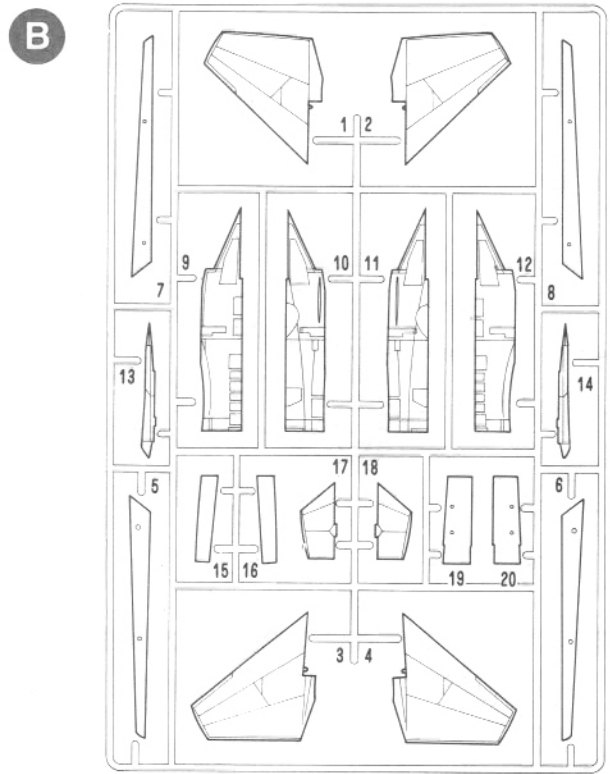
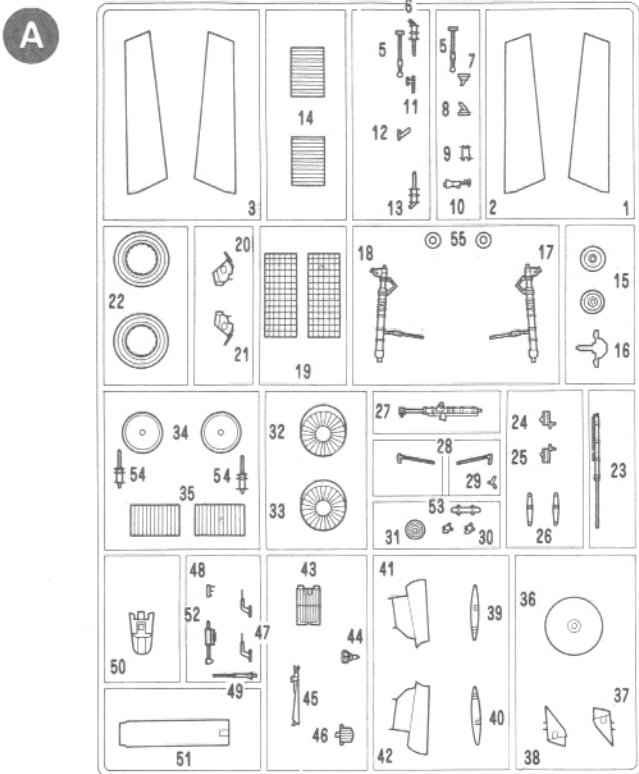

● Unused Parts: A19

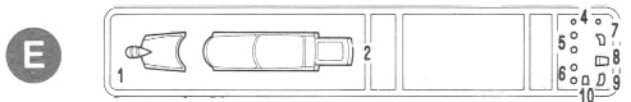
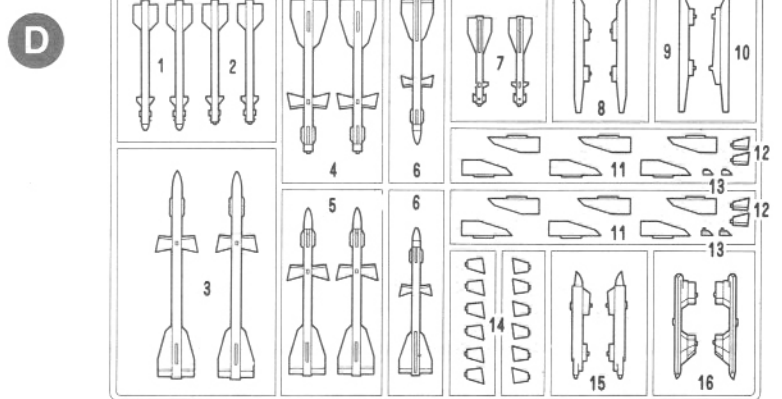
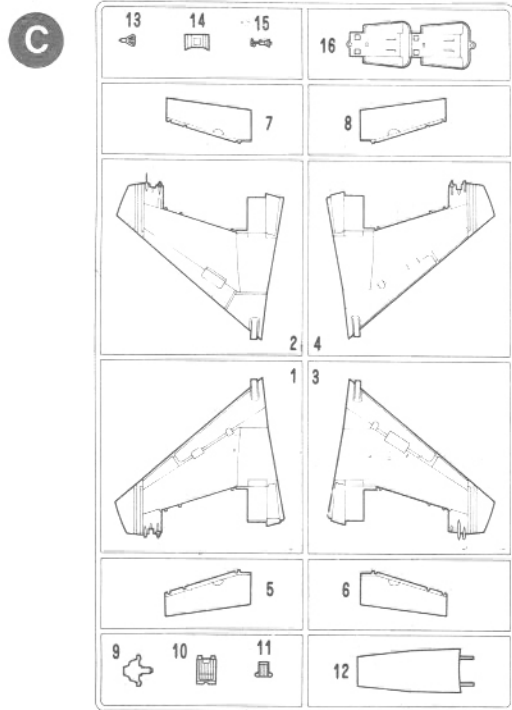

- P.V.C. Tires(Large) × 2
- P.V.C. Tire(Small) × 1
- Fuselage(Upper) × 1
- Fuselage(Lower) × 1
- Decal × 1

● Photo-Etched Part

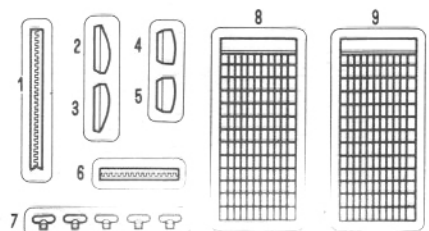

ENGLISH	FRENCH	GERMAN	SPANISH	ITALIAN
WHITE	BLANCO	WEISS	BLANC	BIANCO
YELLOW	JAUNE	GELB	AMARILLO	GIALLO
RED	ROUGE	ROT	ROJO	ROSSO
BLUE	BLEU	BLAU	AZUL	BLU
GRAY	GRIS	GRAU	GRIS	GRIGIO
GUNMETAL	METALLIC	METALLIC	METALICO	METALLICO
GREEN	VERT	GRUN	VERDE	VERDE
SILVER	ARGENT	SILBERN	PLATA	ARGENTO
BLACK	NOIR	SCHWARZ	NEGRO	NERO
ORANGE	ORANGE	ORANGE	NARANJADO	ARANCIO
AMBER	AMBRE	BERNSTEINFARBEN	AMBAR	AMBRA
ALUMINUM	ALUMINUM	ALUMINUMFARBEN	ALUMINIO	ALLUMINIO
GLOSS	LUSTRE	GLANZENDES	BRILLANTE	BRILLANTE
FLAT	TERNE	GLANZLOSES	APAGADO	OPACO

## ACADEMY

HOBBY MODEL KITS

## ACADEMY

ACADEMY PLASTIC MODEL CO., LTD.

111, Sanghyeong-dong, Uijeongbu-si, Gyeonggi-do, Korea

TEL: 065-1671-7000

2140