

**fischertechnik** 

**PROFI**

Bauanleitung  
Assembly instruction  
Instructions de montage  
Bouwhandleiding  
Instrucciones de construcción  
Manual de montagem  
Istruzioni di montaggio  
Инструкция по сборке  
安装说明书



**Didactic Information**

[www.fischertechnik-eLearning.com](http://www.fischertechnik-eLearning.com)

**free download**



**eLearning  
Portal**

**Pneumatic Power**

**5 MODELS**





- Mit dem fischertechnik eLearning Portal geben wir Ihnen die Möglichkeit, noch mehr Hintergrundwissen zum Thema des Baukastens zu erhalten. Über [www.fischertechnik-elearning.com](http://www.fischertechnik-elearning.com) gelangen Sie direkt zum eLearning Portal.
- With the fischertechnik eLearning portal, we are giving you the opportunity to obtain even more background knowledge on the topic of the construction set. You can access the eLearning portal directly via [www.fischertechnik-elearning.com](http://www.fischertechnik-elearning.com).
- Avec le portail eLearning de fischertechnik, vous pouvez parfaire vos connaissances au sujet de la boîte de construction. Cliquez sur [www.fischertechnik-elearning.com](http://www.fischertechnik-elearning.com) pour accéder directement à notre portail.
- Met het fischertechnik eLearning portaal geven wij u de mogelijkheid, nog meer achtergrondkennis over het thema van het modulaire systeem te verkrijgen. Via [www.fischertechnik-elearning.com](http://www.fischertechnik-elearning.com) komt u direct bij het eLearning portaal.
- Con el portal de aprendizaje electrónico de fischertechnik le ofrecemos la oportunidad de obtener más conocimientos básicos sobre el tema de los módulos. A través de [www.fischertechnik-elearning.com](http://www.fischertechnik-elearning.com) podrá acceder directamente al portal de aprendizaje electrónico.
- Com o portal de eLearning da fischertechnik damos lhe a possibilidade de obter ainda mais conhecimentos aprofundados sobre os kits de construção. Em [www.fischertechnik-elearning.com](http://www.fischertechnik-elearning.com) pode aceder diretamente ao portal de eLearning.
- Con il portale eLearning di fischertechnik vi diamo la possibilità di accumulare maggiori informazioni di base sul tema delle scatole di montaggio. Tramite [www.fischertechnik-elearning.com](http://www.fischertechnik-elearning.com) potete raggiungere direttamente il portale eLearning.
- Обучающий Интернет-портал компании fischertechnik предлагает вам возможность получить больше базовых знаний по теме конструирования. По ссылке [www.fischertechnik-elearning.com](http://www.fischertechnik-elearning.com) вы попадаете прямо на обучающий Интернет-портал.
- 通过 fischertechnik eLearning 电子学习门户网站，我们为您提供更多关于积木的背景知识。登陆 [www.fischertechnik-elearning.com](http://www.fischertechnik-elearning.com) 访问我们的 eLearning 门户网站。



- Werde Mitglied im kostenlosen fischertechnik Fan Club und nutze die Vorteile. Melde dich hierzu einfach unter [www.fischertechnik.de/FanClub](http://www.fischertechnik.de/FanClub) an.
- Become a member of the free fischertechnik fan club and take advantage of the benefits. Simply register at [www.fischertechnik.de/FanClub](http://www.fischertechnik.de/FanClub)
- Deviens membre du Fan club fischertechnik gratuit et profite de nombreux avantages. Il suffit de t'inscrire sur [www.fischertechnik.de/FanClub](http://www.fischertechnik.de/FanClub).
- Word lid van de gratis fischertechnik Fan Club en maak gebruik van de voordelen. Meldt u hiervoor aan op [www.fischertechnik.de/FanClub](http://www.fischertechnik.de/FanClub).
- Hazte miembro del club de aficionados gratuito de fischertechnik y disfruta de todas las ventajas. Regístrate en [www.fischertechnik.de/FanClub](http://www.fischertechnik.de/FanClub).
- Torne-se um membro do fã-clube gratuito da Fischertechnike aproveite-a. Basta registrar-se em [www.fischertechnik.de/FanClub](http://www.fischertechnik.de/FanClub).
- Diventa membro del fan club gratuito di fischertechnik e sfrutta tutti i vantaggi. Basta registrarsi a [www.fischertechnik.de/FanClub](http://www.fischertechnik.de/FanClub).
- Стань членом бесплатного фан-клуба fischertechnik и пользуйся преимуществами. Для этого просто зарегистрируйся по адресу [www.fischertechnik.de/FanClub](http://www.fischertechnik.de/FanClub).
- x免费加入慧鱼粉丝俱乐部 (fischertechnik Fan Club) 会员，即刻享受会员福利。只需前往 [www.fischertechnik.de/FanClub](http://www.fischertechnik.de/FanClub) 完成注册即可。



**Inhalt**  
**Contents**  
**Contenu**

**Inhoud**  
**Contenido**  
**Conteúdo**

**Contenuto**  
**Содержание**  
**目录**

Einzelteilübersicht / Spare parts list / Liste des pièces détachées / Onderdelenoverzicht / Lista da piezas / Resumo de peça individual /  
Singoli componenti / Перечень деталей / 零件概览 ..... 2

Montagetips / Tips for assembly / Tuyaux pour le montage / Montagetips / Consejos para el montaje / "Dicas" para montagem /  
Consigli per il montaggio / Советы по сборке / 装配建议 ..... 3

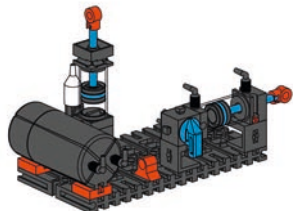

Funktionsmodell / Function model / Maquette fonctionnelle / Functiemodel /  
Modelo funcional / Modelo funcional / Modello di funzionamento /  
Действующая модель / 功能模型 ..... 4

Werkstattkran / Workshop crane / Grue d'atelier / Werkplaatskraan /  
Grúa de taller / Guincho para oficina / Gru da oficina / Цеховой кран /  
车间吊机 ..... 6

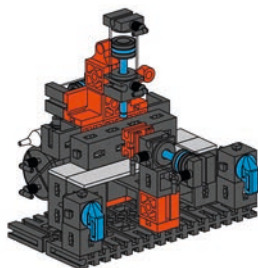
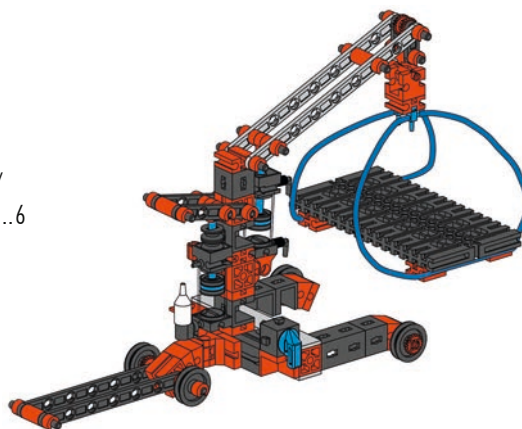





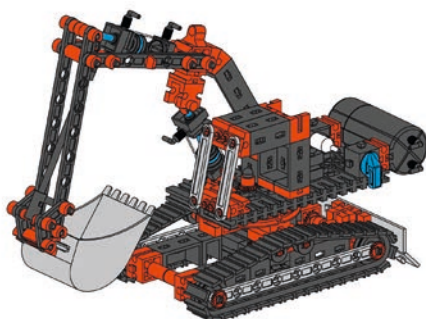
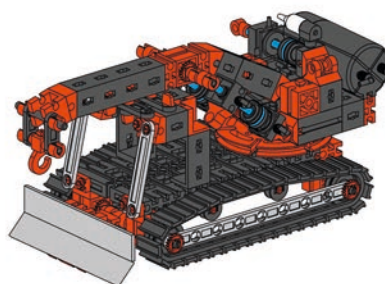









Stanzmaschine / Punch press / Découpeuse / Stansmachine /  
Punzonadora / Máquina de puncionar / Fustellatrice /  
Штамповочная машина / 冲床 ..... 11

Bergungsraupe / Track mounted recovery vehicle / Chenille de sauvetage /  
Bergingsvoertuig op rupsbanden / Oruga de salvamento / Lagarta de  
salvamento / Cingolato di salvataggio / Спасательный трактор /  
履带式抢险车 ..... 14













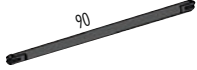

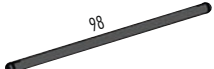
Bagger / Excavator / Pelle / Graafmachine / Excavadora / Escavadeira /  
Escavatore / Экскаватор / 挖掘机 ..... 19

**Einzelteilübersicht**  
**Spare parts list**  
**Liste des pièces détachées**

	31 011 2 x
	31 019 1 x
	31 057 2 x
	31 058 1 x
	31 422 3 x
	31 426 3 x
	31 436 3 x
	31 597 14 x
	31 642 2 x
	31 690 1 x
	31 981 3 x
	31 982 11 x
	31 983 3 x
	32 064 7 x

**Onderdelenoverzicht**  
**Lista da piezas**  
**Resumo de peça individual**

	32 870 1 x
	32 879 2 x
	35 031 1 x
	35 066 1 x
	35 129 1 x
	35 414 2 x
	35 797 4 x
	35 969 2 x
	35 975 4 x
	35 980 1 x
	36 227 2 x
	36 323 6 x
	36 334 15 x
	36 586 4 x

	36 913 2 x
	36 914 4 x
	36 915 6 x
	36 920 8 x
	36 921 1 x
	36 922 6 x
	36 934 2 x
	36 970 1 x
	37 237 6 x
	37 468 7 x
	37 636 1 x
	37 679 27 x
	38 225 1 x
	38 240 2 x

**Singoli componenti**  
**Перечень деталей**  
**零件概览**

	38 258 4 x
	38 411 1 x
	38 413 3 x
	38 414 6 x
	38 416 1 x
	38 543 2 x
	38 546 2 x
	122 641 3 x
	153 367 2 x
	156 104 1 x
	156 105 2 x
	156 106 2 x
	156 107 1 x
	156 493 1 x

**Montagetipps**  
**Tips for assembly**  
**Tuyaux pour le montage**

**Montagetips**  
**Consejos para el montaje**  
**"Dicas" para montagem**

**Consigli per il montaggio**  
**Советы по сборке**  
**装配建议**

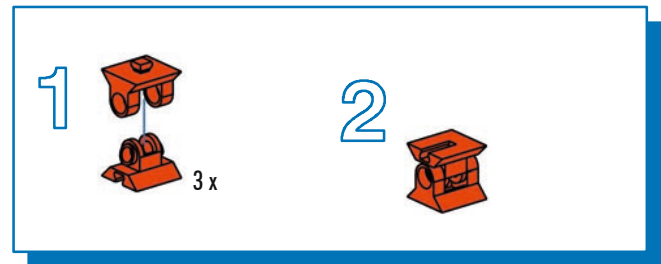
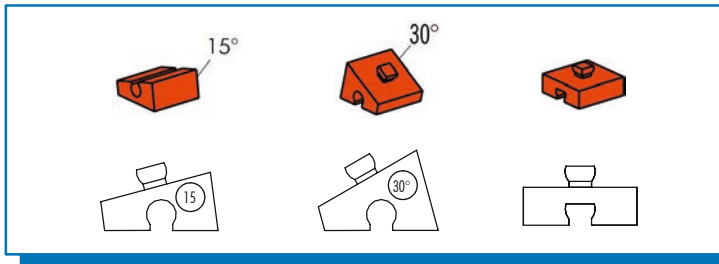

Schlauchzuschnitte  
 Hose cut to length  
 Découpes de tuyau

Slangdelen  
 Recortes de tubos flexibles  
 Recortes de mangueira

Spezzoni di tubo  
 Штуцеры  
 软管段

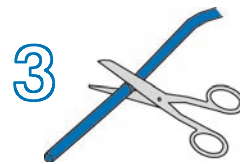
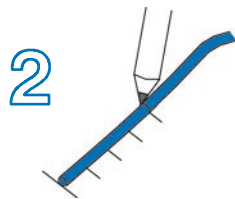
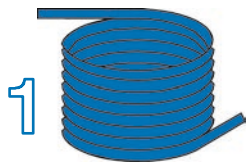

2 x 5 cm  
 2 x 10 cm  
 2 x 20 cm  
 2 x 25 cm

**Sicherheitshinweise**  
**Safety Information**  
**Consignes de sécurité**

**Veiligheidsrichtlijnen**  
**Indicaciones de seguridad**  
**Observações sobre segurança**

**Informazioni per la sicurezza**  
**Указания по технике безопасности**  
**安全指南**

- Alle Einzelteile, insbesondere bewegliche Teile sind falls notwendig zu warten und zu reinigen.
- All components, especially moving parts, should be maintained and cleaned as necessary.
- Toutes les pièces détachées et en particulier les pièces mobiles, sont, si nécessaire, à entretenir et à nettoyer.
- Alle onderdelen, vooral de bewegende delen, kunnen, indien noodzakelijk, onderhouden en gereinigd worden.
- Es necesario limpiar y mantener en buen estado todas las diferentes piezas - especialmente las piezas móviles.
- Caso necessário, todas as peças individuais, especialmente peças móveis, tem que ser submetidas à manutenção e ser limpadas.
- Se necessario, tutti i singoli componenti, soprattutto le parti mobili, si devono eventualmente sottoporre a manutenzione e pulizia.
- Все детали, особенно подвижные, требуют ухода и чистки.
- 必要时应保养和清洁所有零件，尤指运动部件。

25 cm  
20 cm  
15 cm  
10 cm  
5 cm  
0

Funktionsmodell  
Function model  
Maquette fonctionnelle

Funciemodel  
Modelo funcional  
Modelo funcional

Modello di funzionamento  
Действующая модель  
功能模型

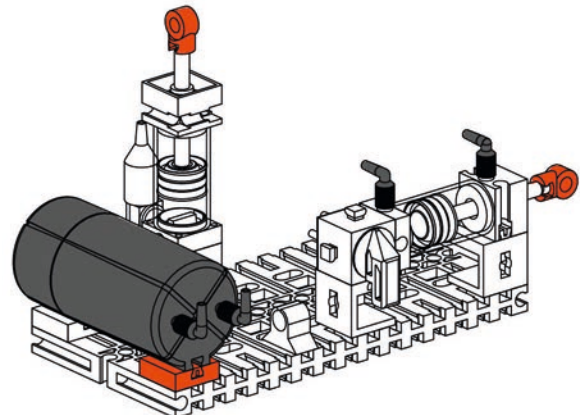
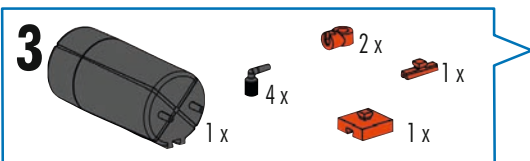
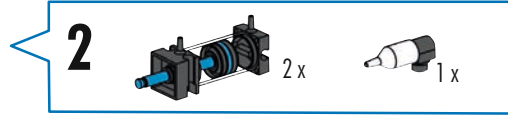
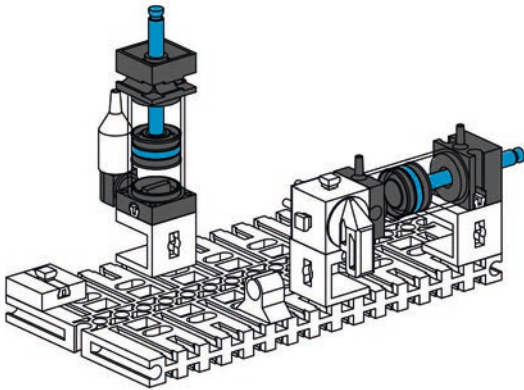
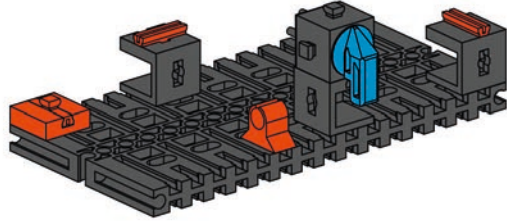
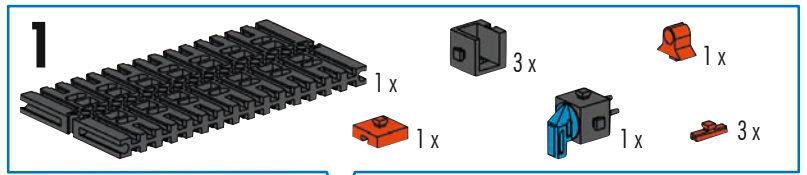
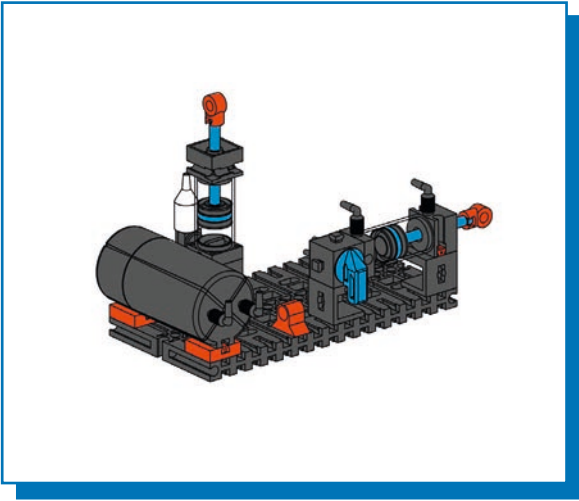

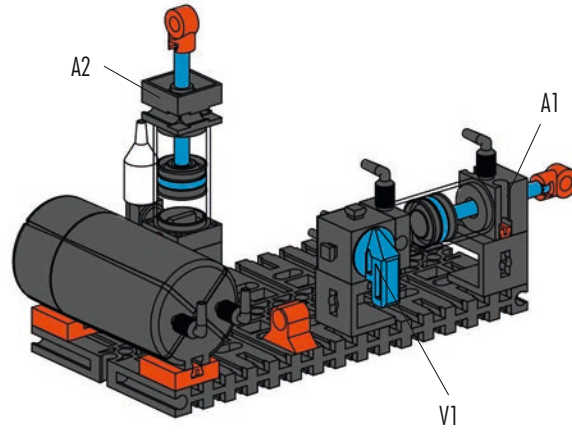

Schlauchanschlussplan  
Air line layout plan  
Plan de raccordement de conduits

Aansluitschema van slang  
Racor de empalme  
Plano de conexão de mangueira

Schema di allacciamento tubi  
Схема подключения шлангов  
软管连接图

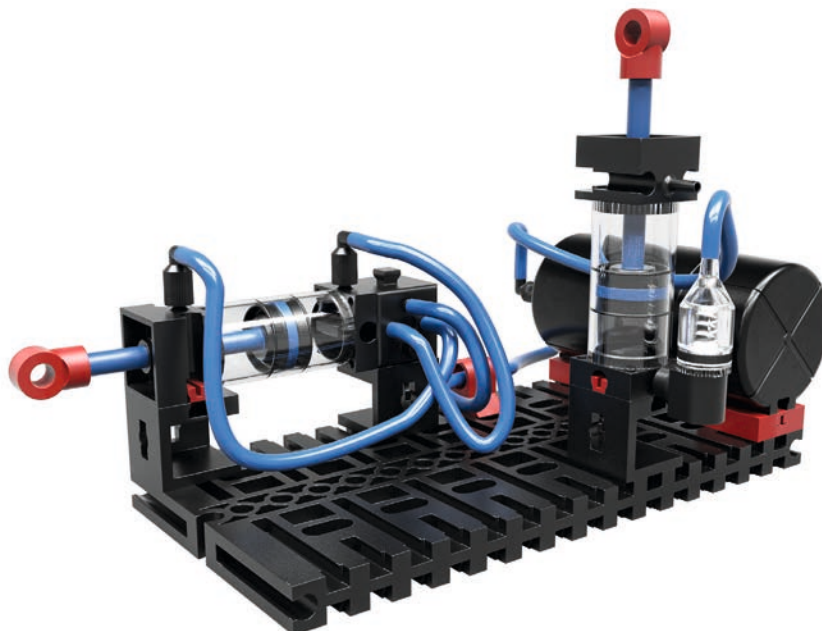
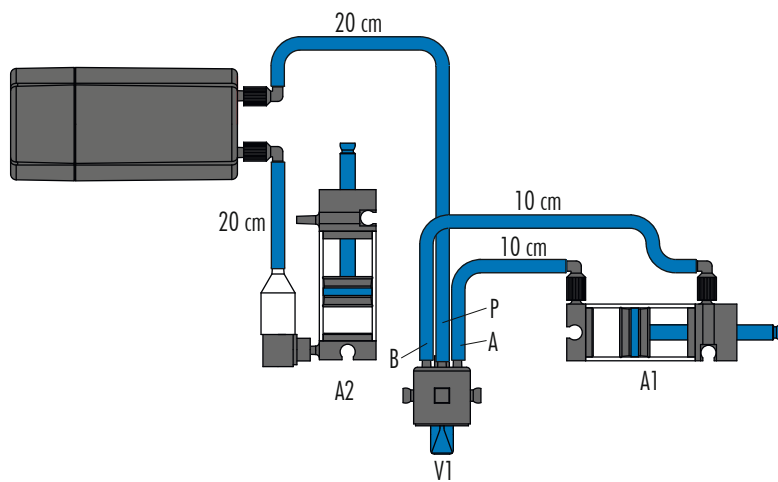



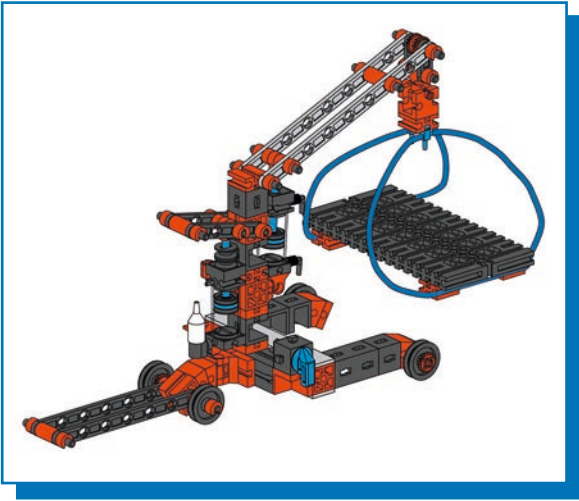









Werkstattkran  
Workshop crane  
Grue d'atelier

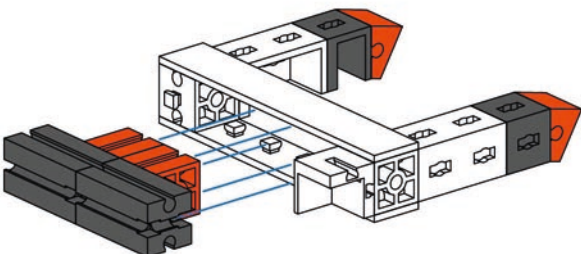
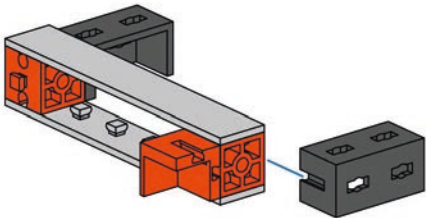

Werkplaatskraan  
Grúa de taller  
Guincho para oficina

Gru da officina  
Цеховой кран  
车间吊机

- 1**  2x  2x  2x  1x



- 2**  2x  2x  2x  2x

- 3**  3x  2x  1x

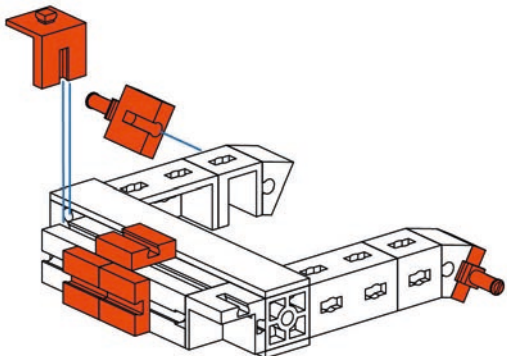



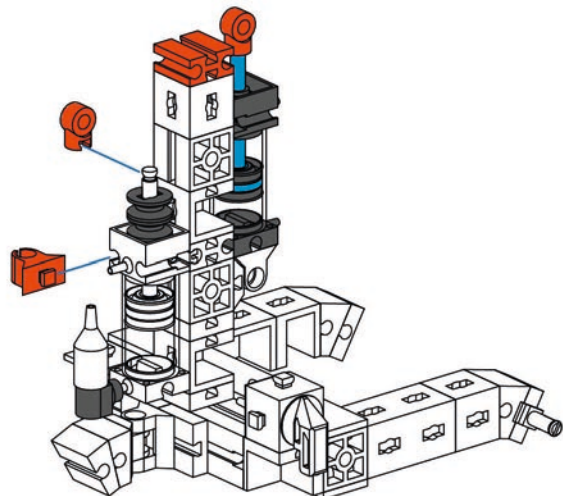
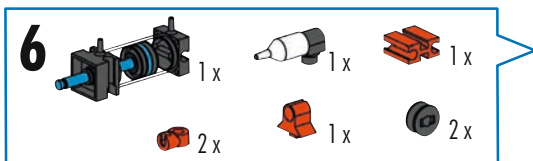
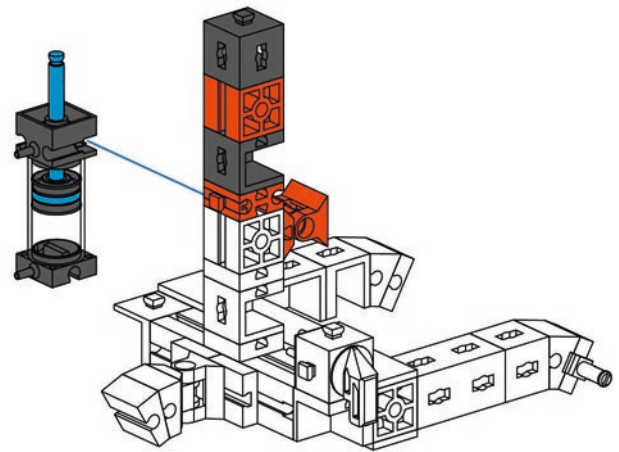
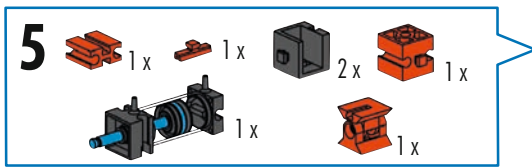
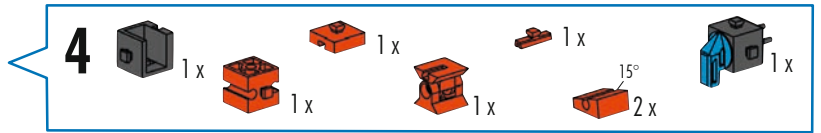
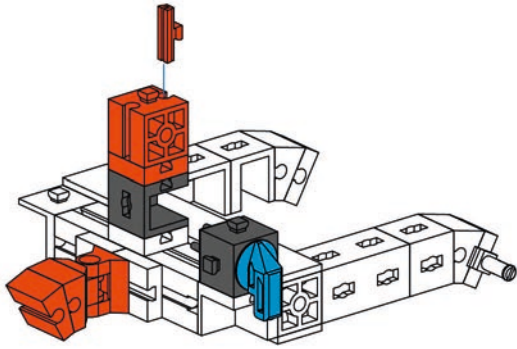

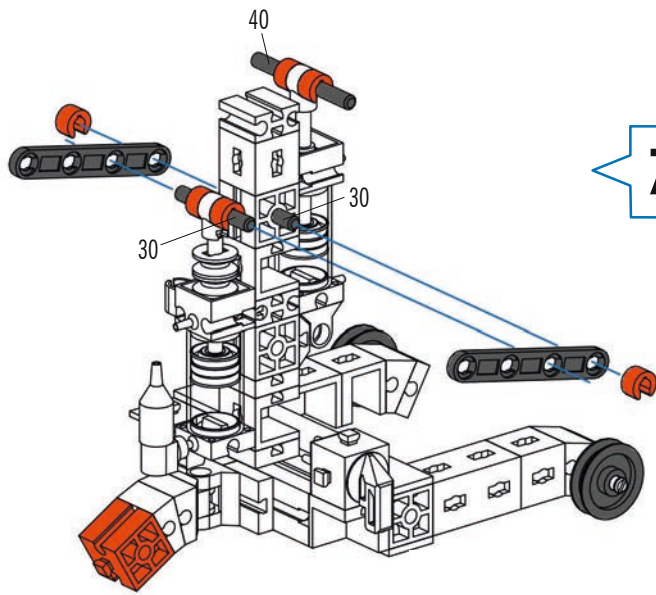

**7**

- 1 x Red 1-hole Technic brick
- 2 x Black Technic bush
- 6 x Red Technic bush
- 2 x Black Technic axle of length 45
- 2 x Black Technic axle of length 30
- 1 x Black Technic axle of length 40

30 mm  
40 mm

**8**

- 2 x Black Technic axle of length 120
- 2 x Black Technic axle of length 90
- 1 x Black Technic axle of length 60
- 2 x Red Technic bush
- 3 x Black Technic axle of length 40
- 10 x Red Technic bush
- 2 x Black Technic bush

40 mm  
60 mm

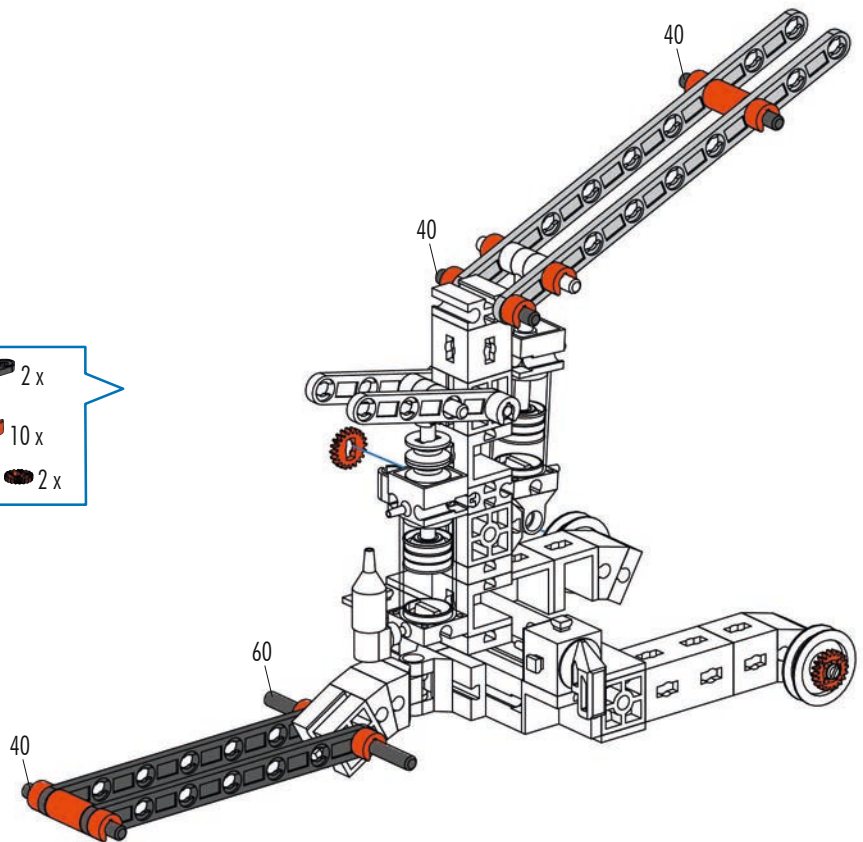

**9**

- 1 x Red Technic bush
- 1 x Black Technic axle of length 30
- 1 x Black Technic axle of length 40
- 1 x Red Technic bush
- 2 x Black Technic bush
- 2 x Black Technic axle of length 15
- 2 x Red Technic bush

30 mm  
40 mm

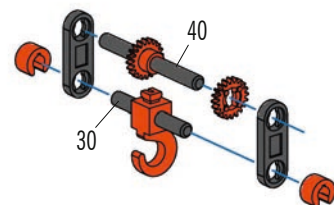

9

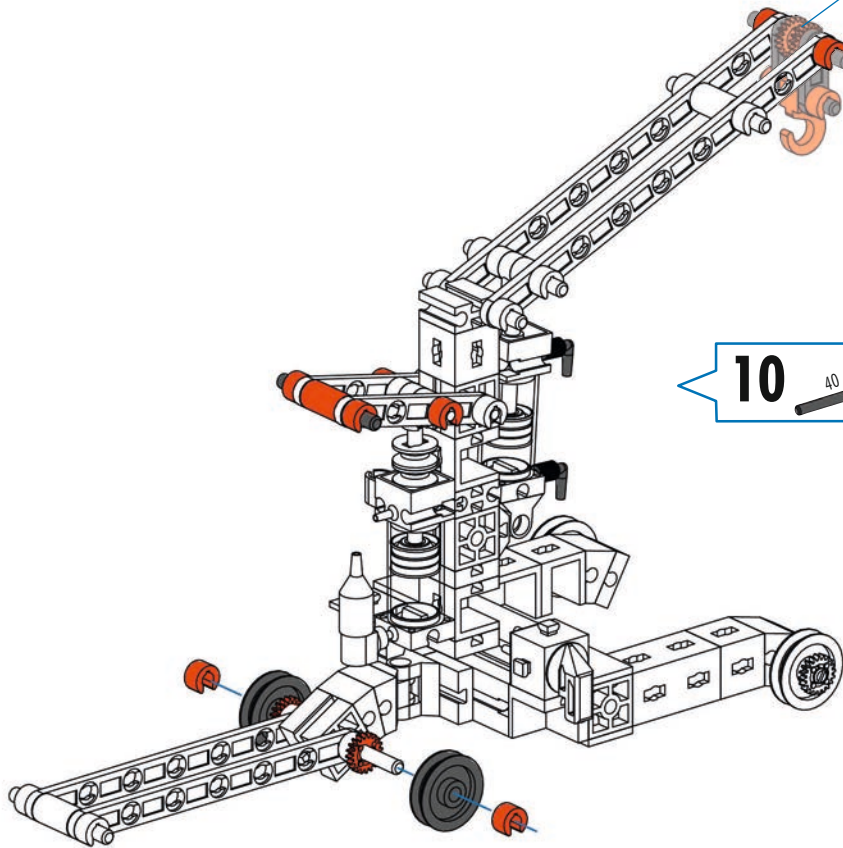

10

- 1 x
- 8 x
- 2 x
- 2 x
- 1 x
- 2 x

40 mm

11

- 1 x
- 4 x
- 4 x

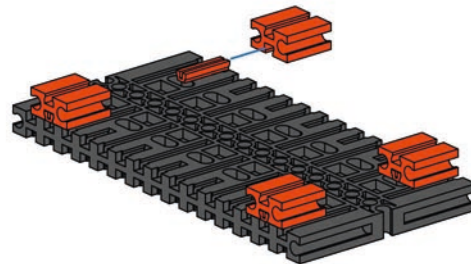

12

- 1 x
- 1 x
- 1 x
- 2 x
- 2 x

25 cm

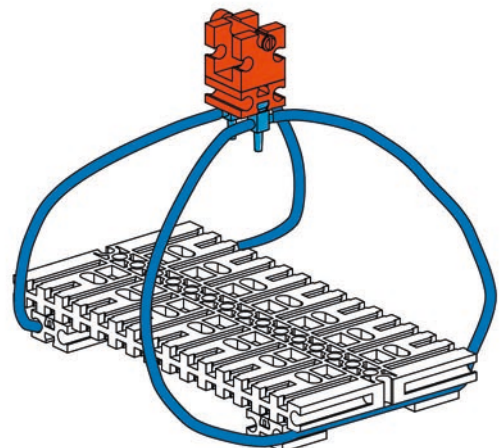



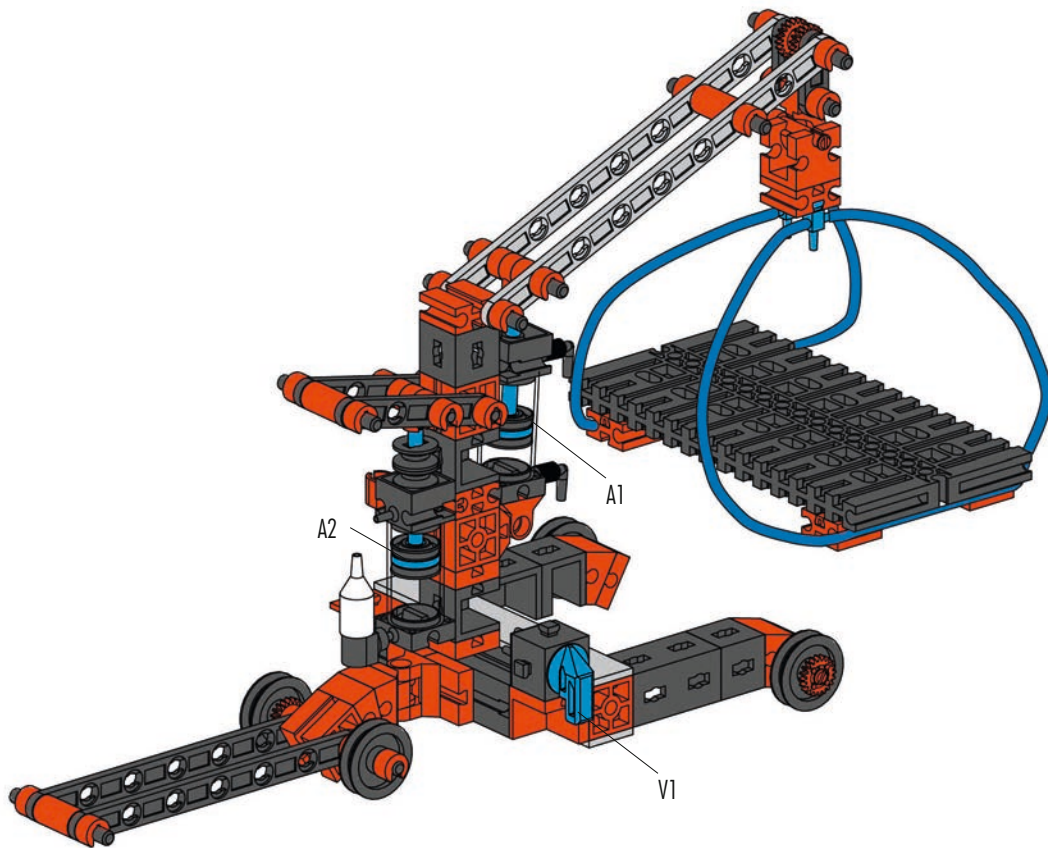

Schlauchanschlussplan  
Air line layout plan  
Plan de raccordement de conduits

Aansluitschema van slang  
Racor de empalme  
Plano de conexão de mangueira

Schema di allacciamento tubi  
Схема подключения шлангов  
软管连接图

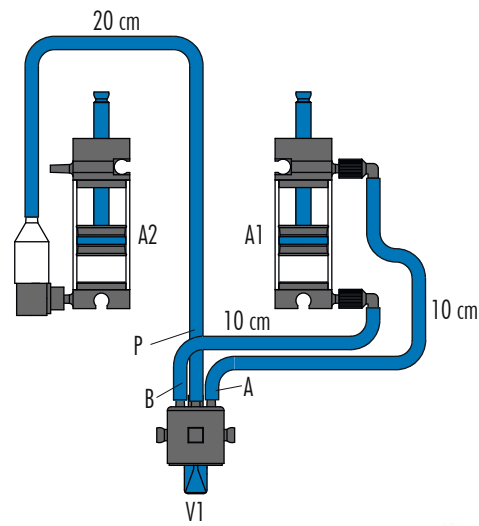

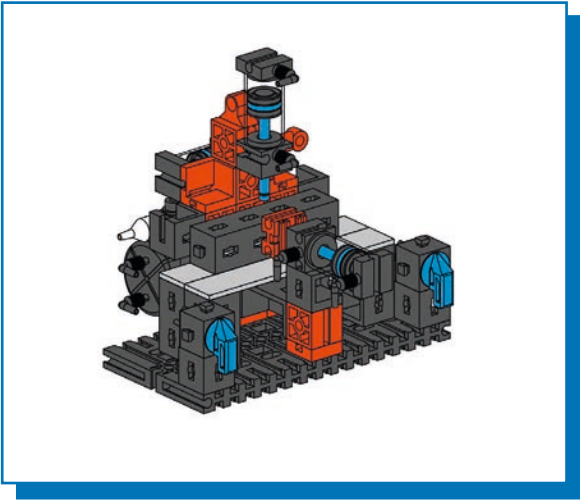

Stanzmaschine  
Punch press  
Découpeuse





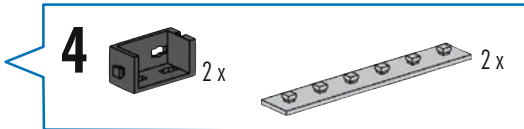
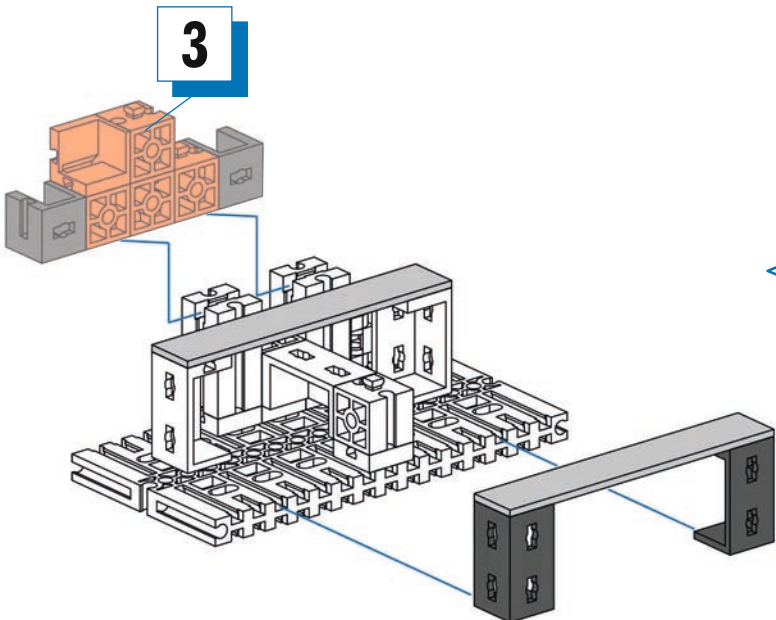
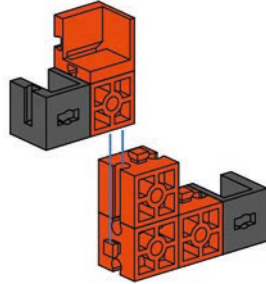
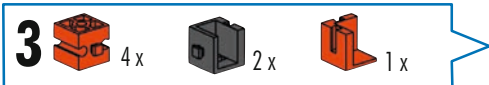
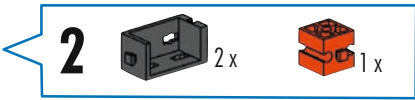
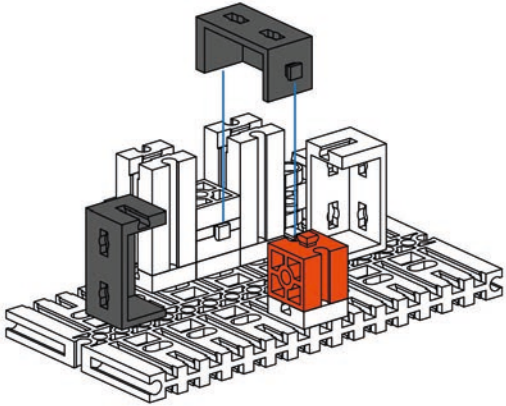
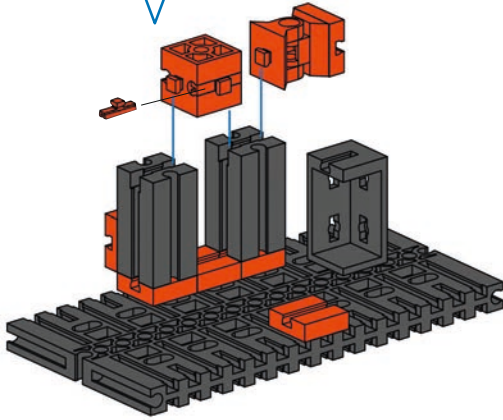
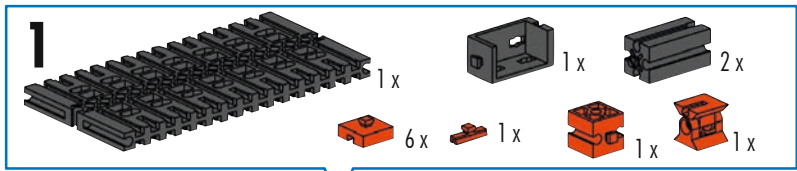

Stansmaschine  
Punzonadora  
Máquina de punchar

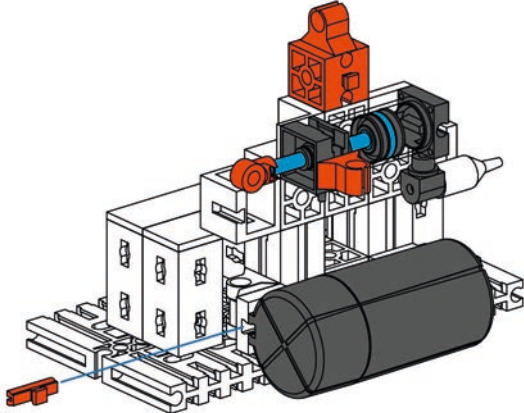
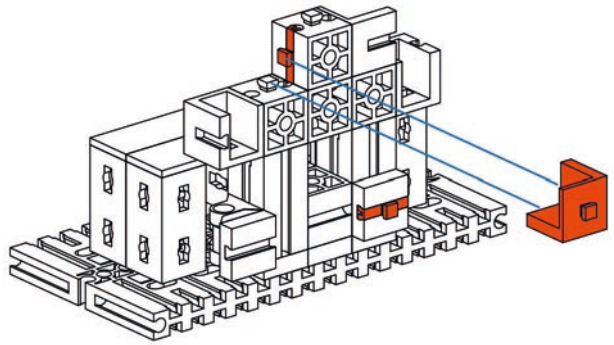

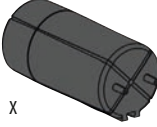
Fustellatrice  
Штамповочная машина  
冲床

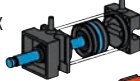



**5**  2x  1x

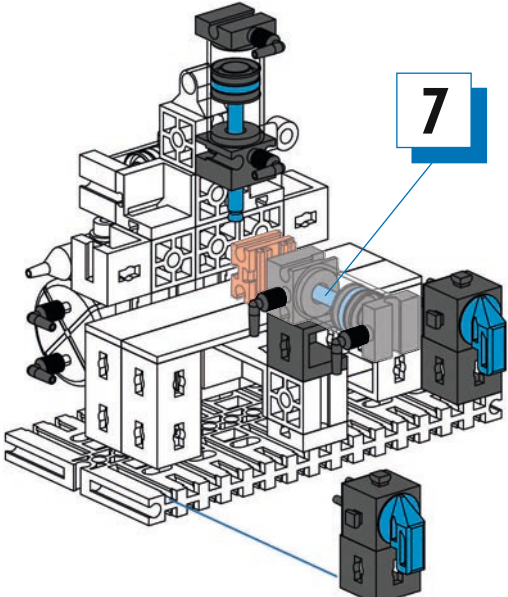
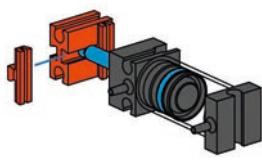

**6**  1x  1x  1x  1x  2x  1x  1x

**7**  1x  1x  2x

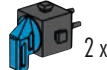

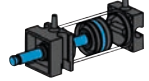
**8**  2x  3x  6x  1x



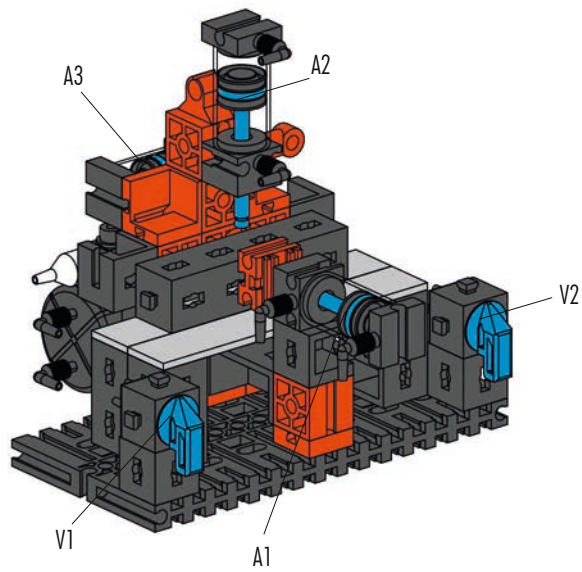

Schlauchanschlussplan  
Air line layout plan  
Plan de raccordement de conduits

Aansluitschema van slang  
Racor de empalme  
Plano de conexão de mangueira

Schema di allacciamento tubi  
Схема подключения шлангов  
软管连接图

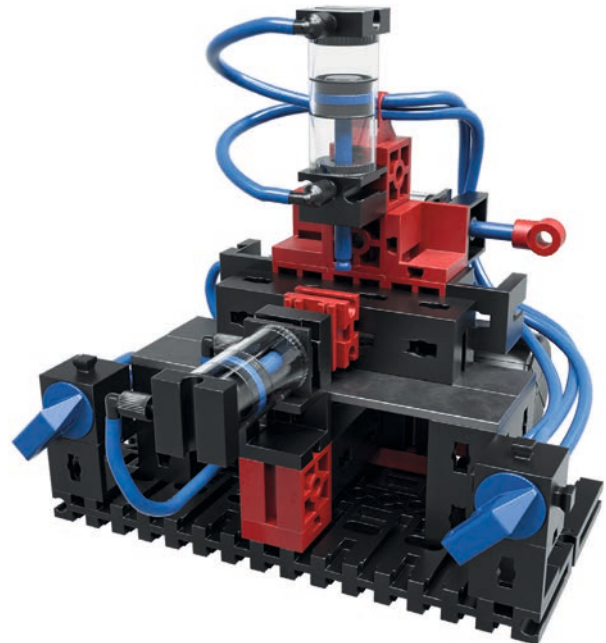
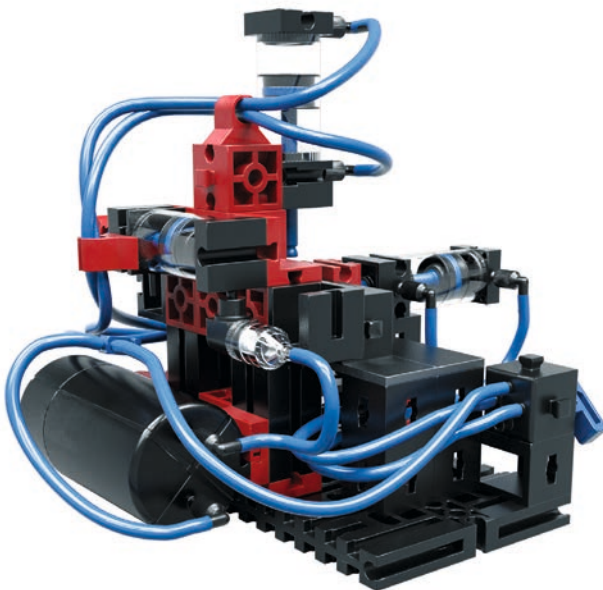
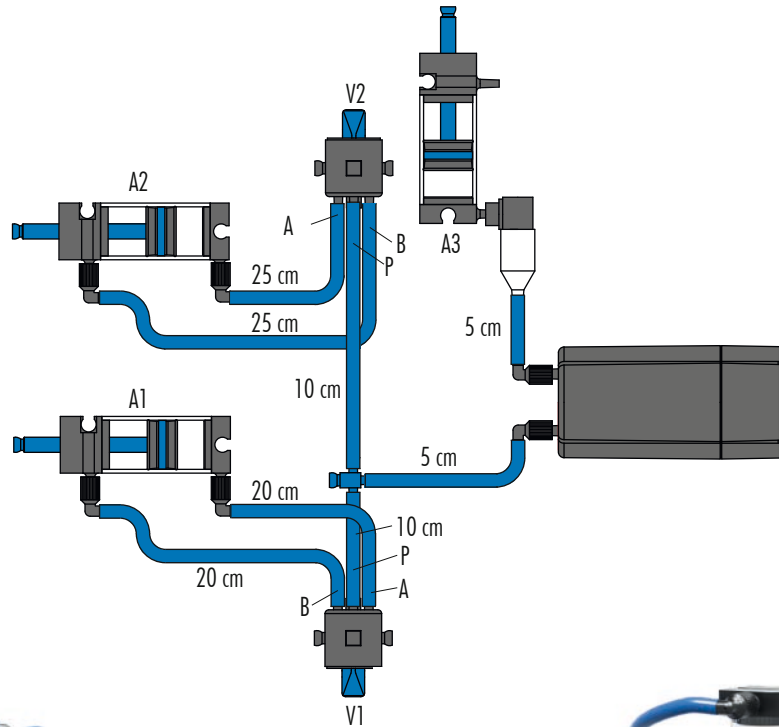

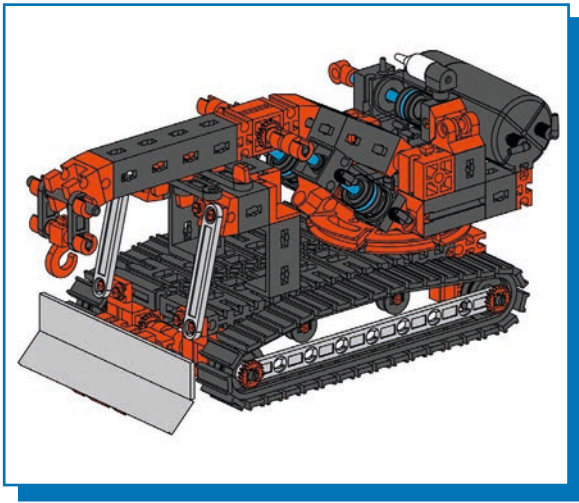

**Bergungsraupe**  
Track mounted recovery  
vehicle  
**Chenille de sauvetage**

**Bergingsvoertuig op rupsbanden**  
**Oruga de salvamento**  
**Lagarta de salvamento**

**Cingolato di salvataggio**  
Спасательный трактор  
履带式抢险车

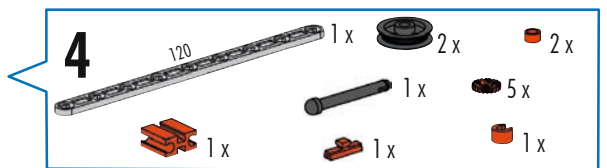
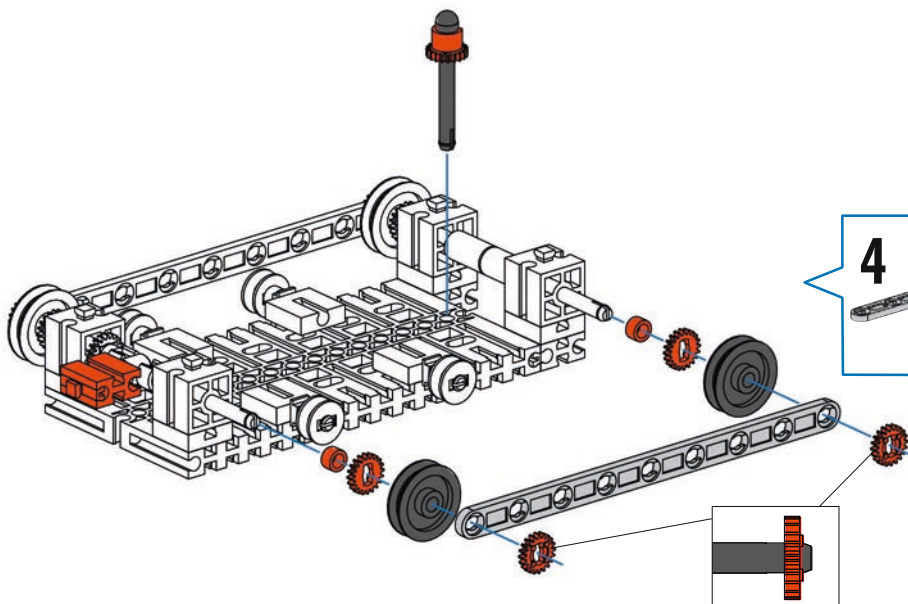
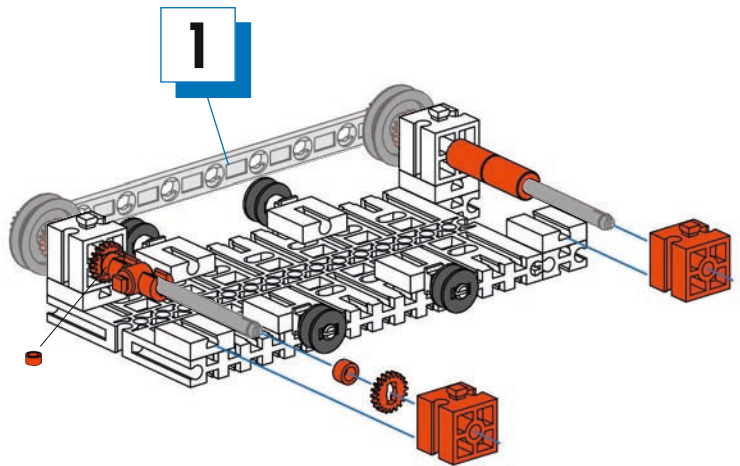
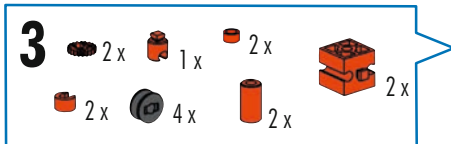
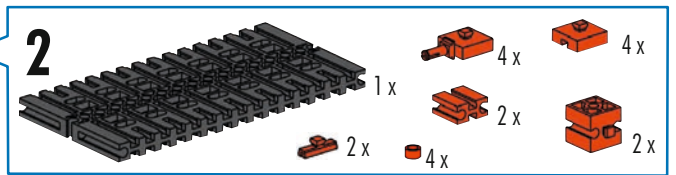
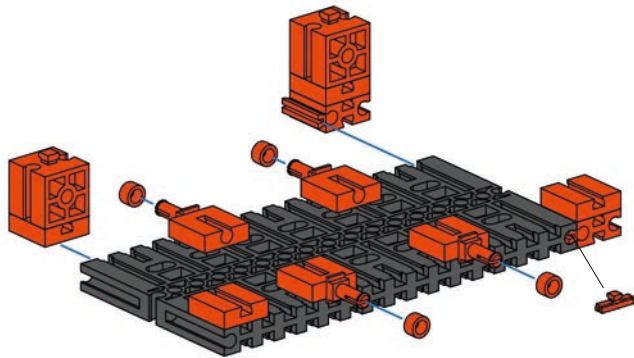
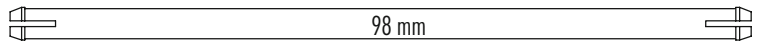
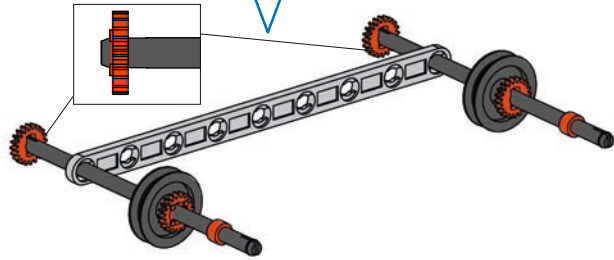
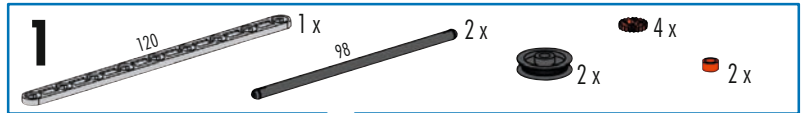



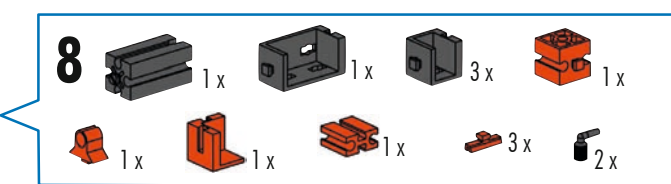
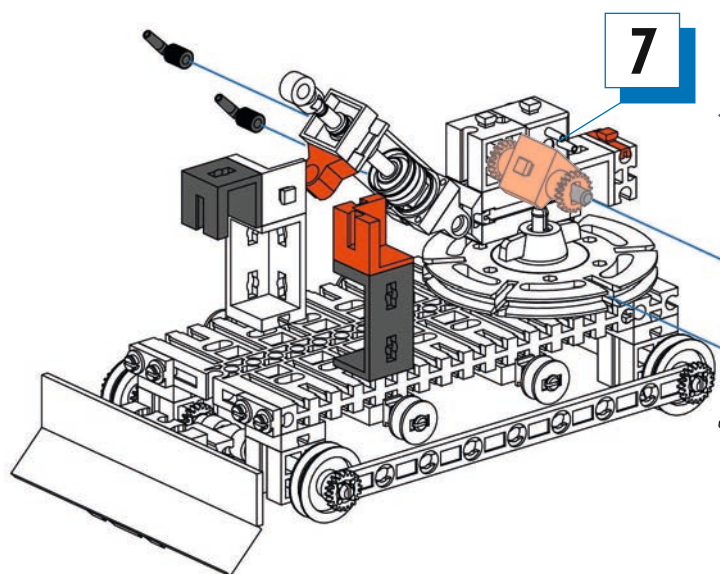
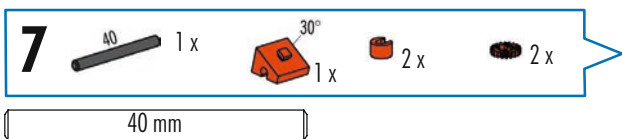
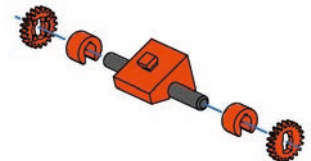
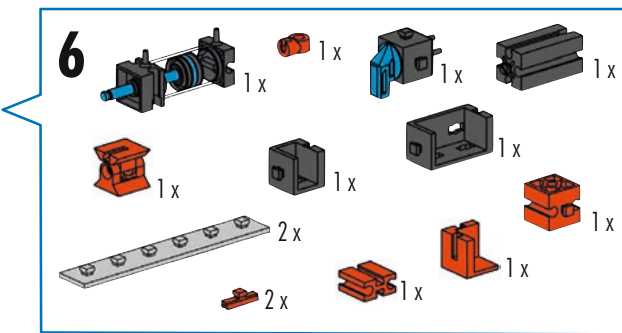
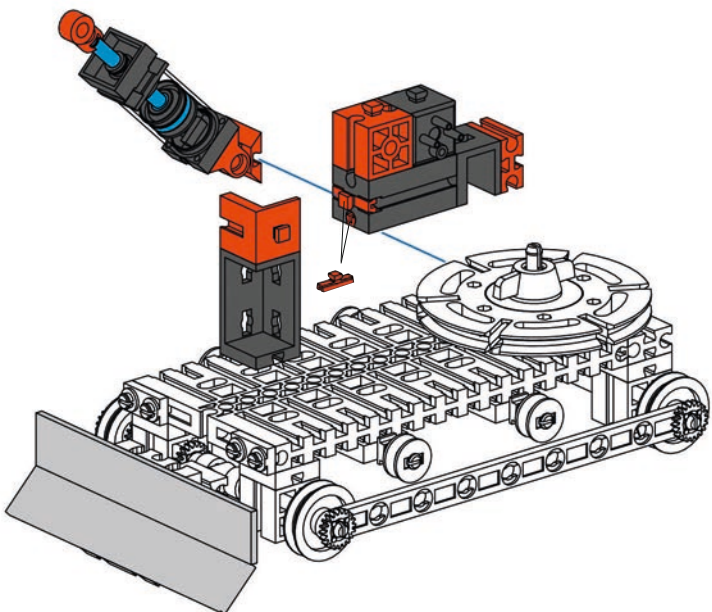
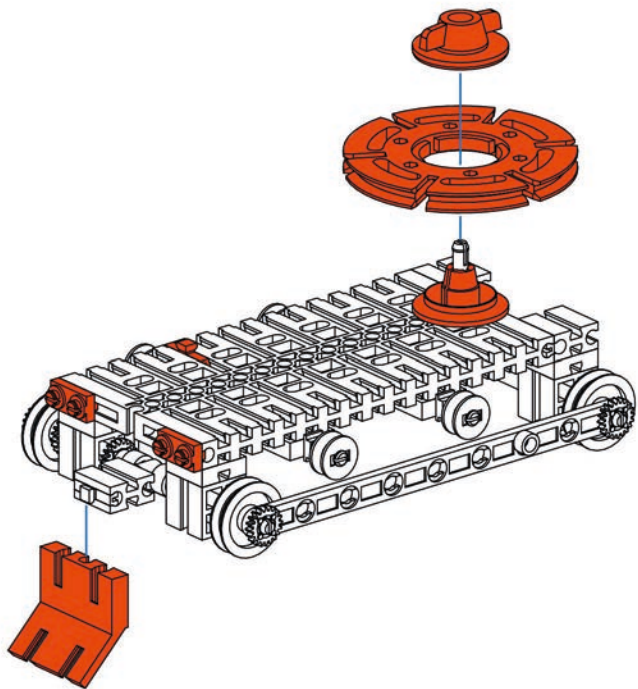
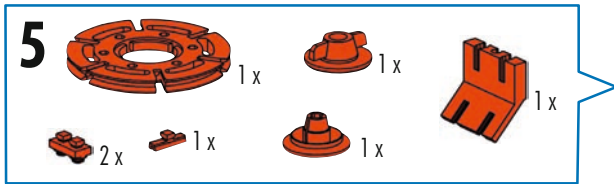



9

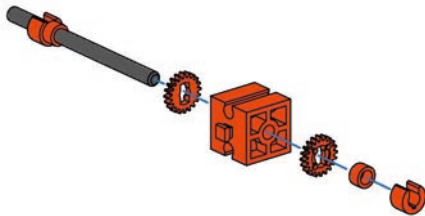
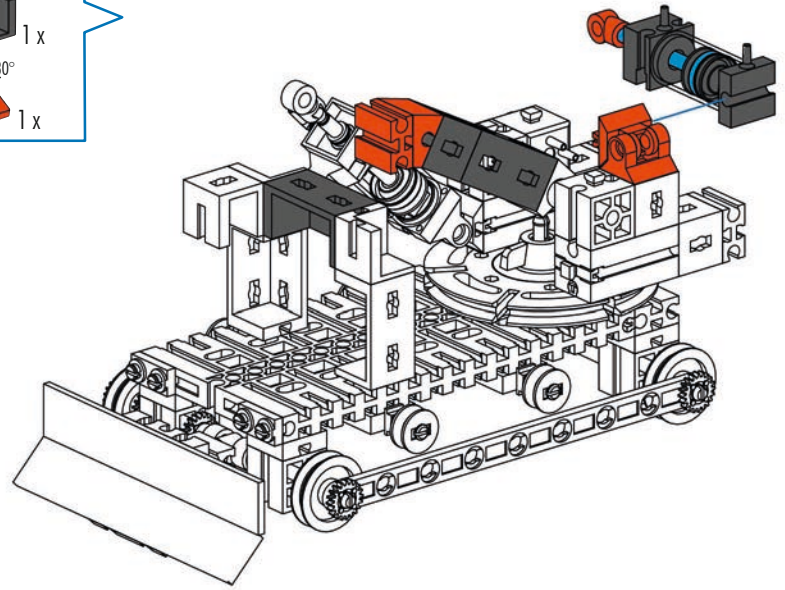
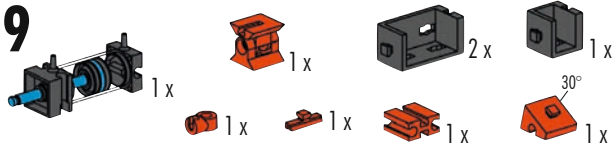

10

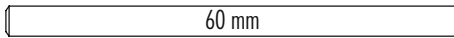

10

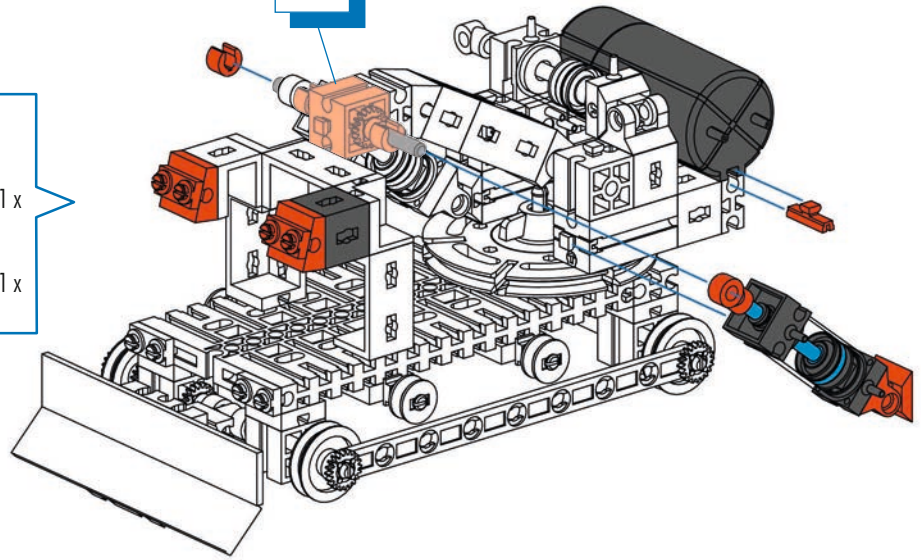

11

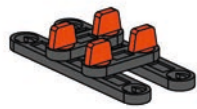
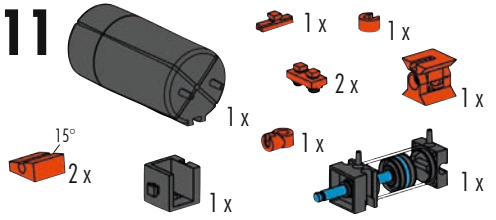

12



12

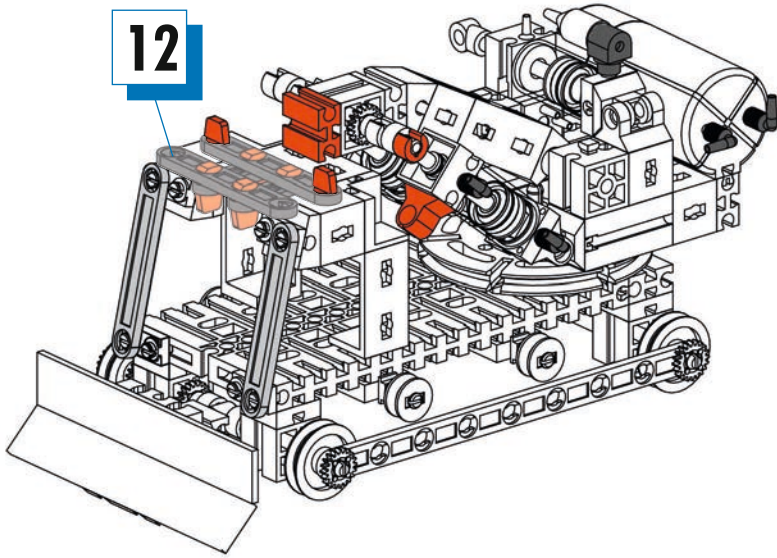

13

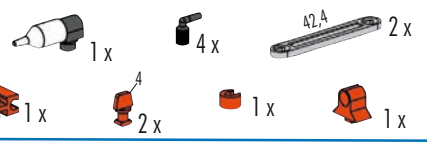

14

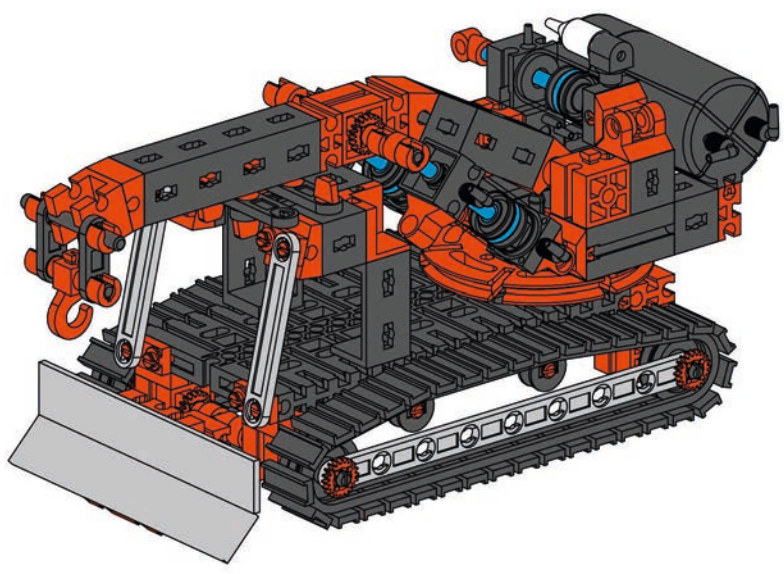
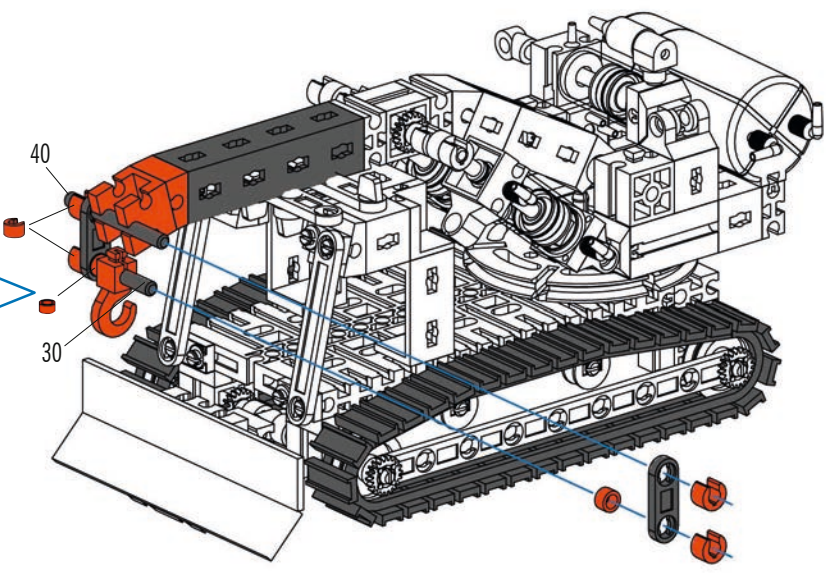
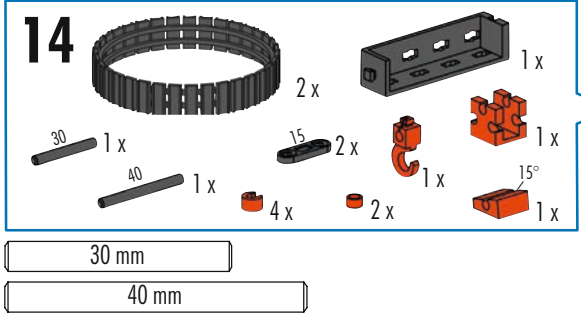



Hochklappen zur Schlauchmontage  
 Fold up to install hose  
 Replier vers le haut pour monter le tuyau  
 Omhoog klappen om slang te monteren  
 Levantar para montar las mangueras  
 Levantar para montar a mangueira  
 Sollevare per montare il tubo  
 Открыть для монтажа шланга  
 向上翻起，以安装软管

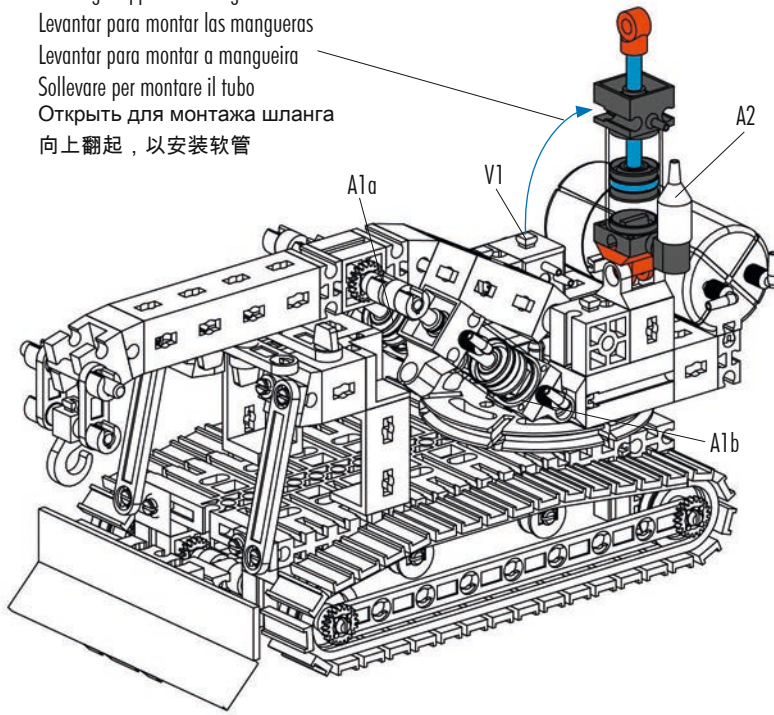

Schlauchanschlussplan  
 Air line layout plan  
 Plan de raccordement de conduits

Aansluitschema van slang  
 Racor de empalme  
 Plano de conexão de mangueira

Schema di allacciamento tubi  
 Схема подключения шлангов  
 软管连接图

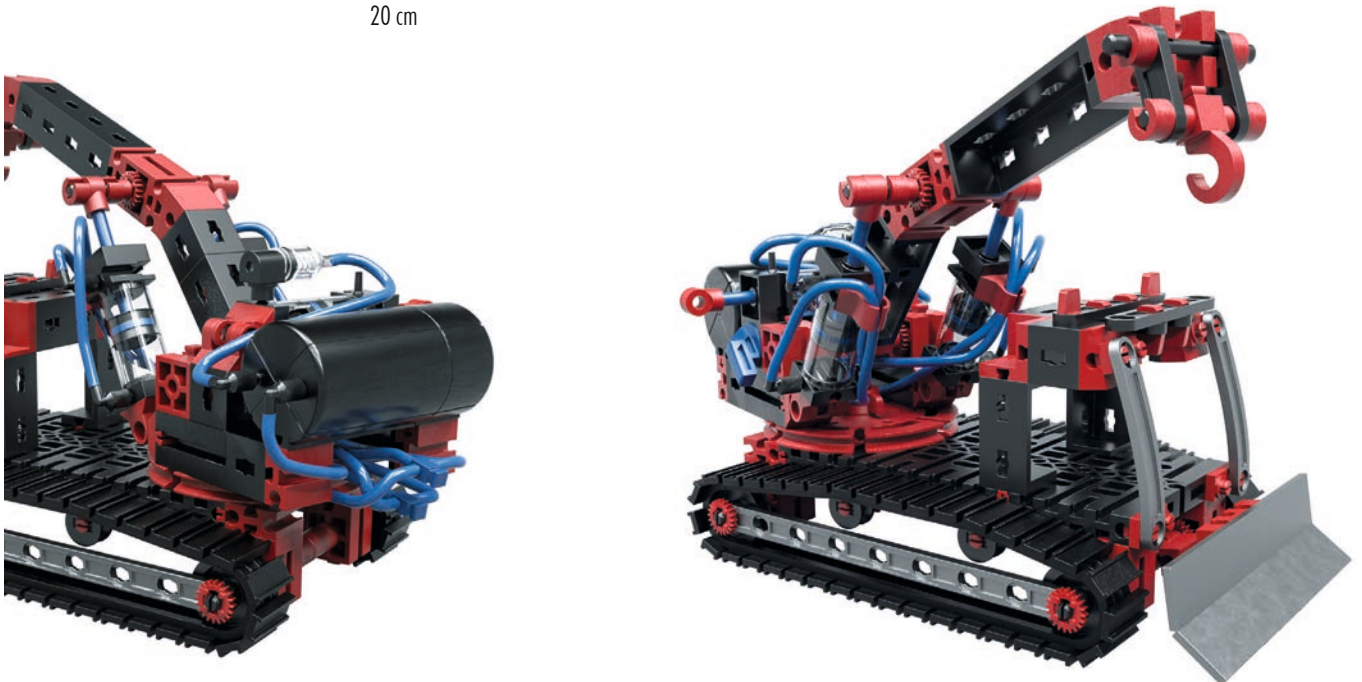
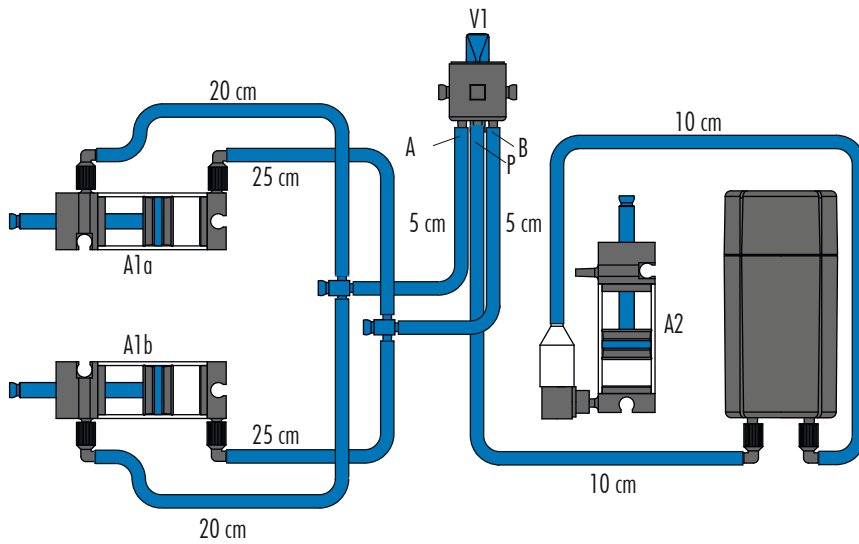



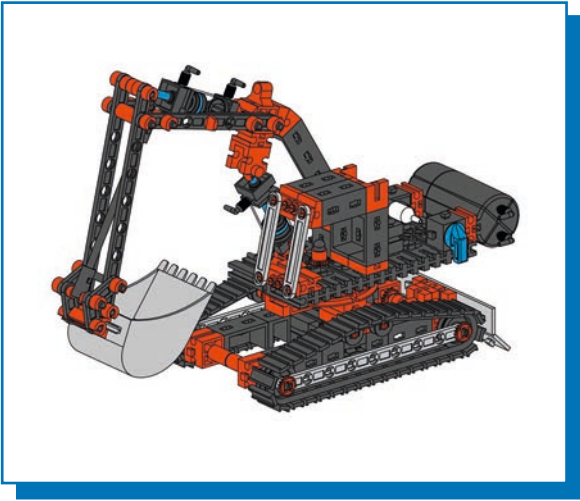

**Bagger**  
Excavator  
Pelle

**Graafmachine**  
Excavadora  
Escavadeira

**Escavatore**  
Экскаватор  
挖掘机

**1**

- 120 1x
- 98 2x
- 4x
- 2x
- 2x

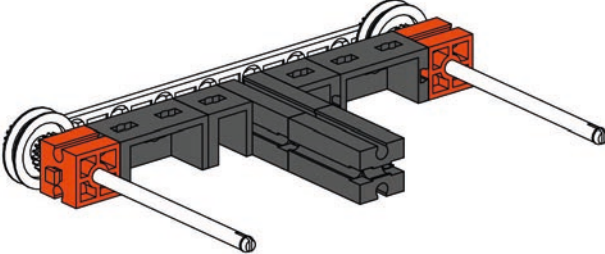
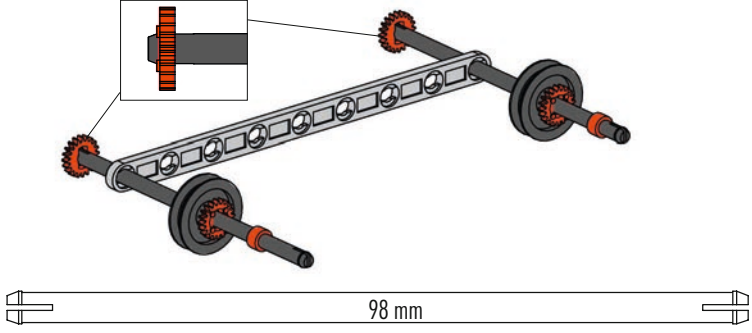

**2**

- 2x
- 2x
- 2x
- 2x

**3**

- 2x
- 1x
- 2x
- 2x
- 2x

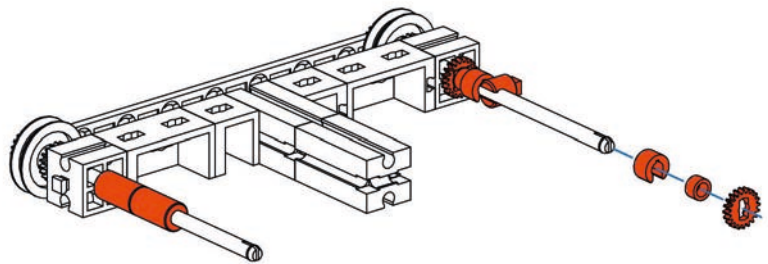

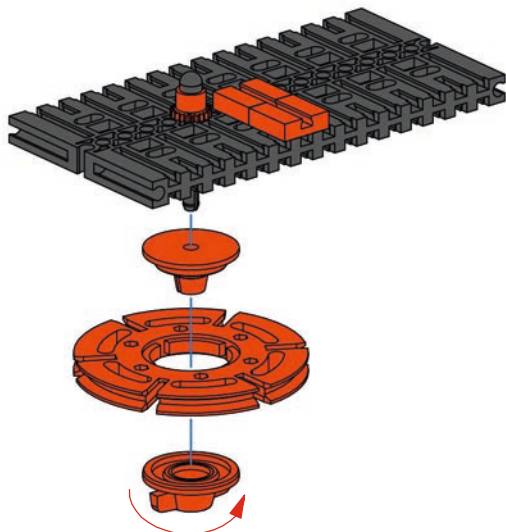
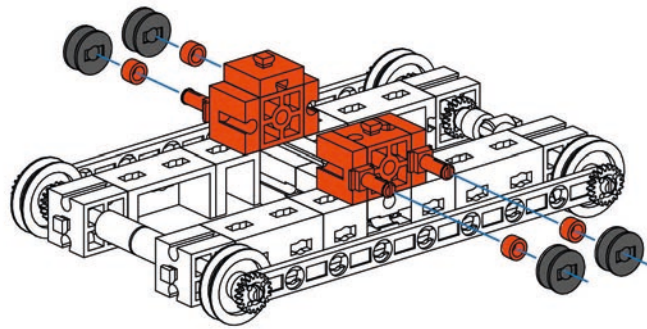
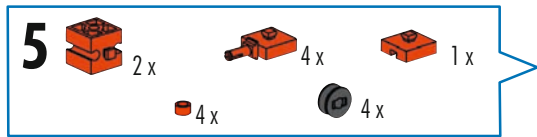
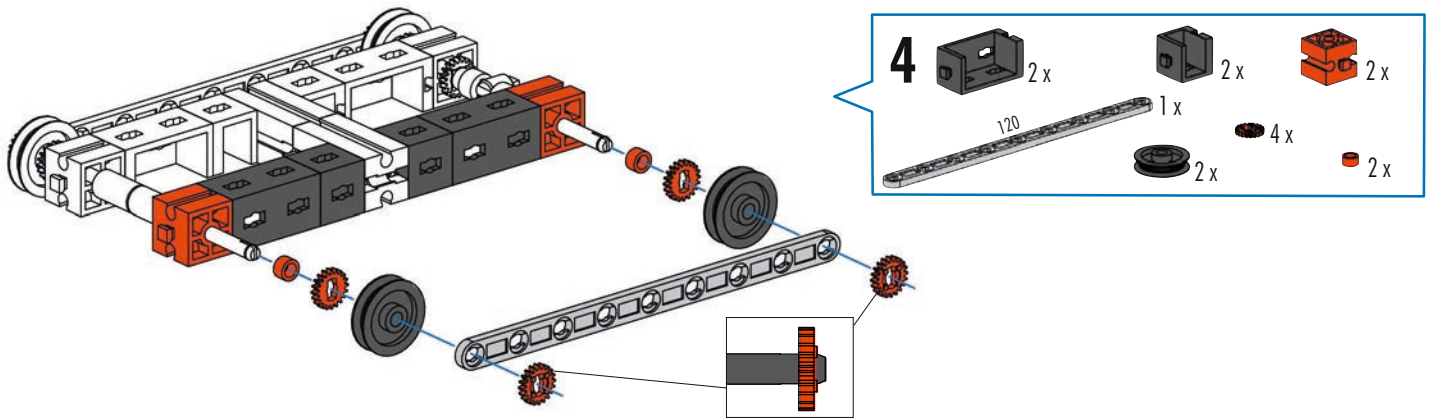





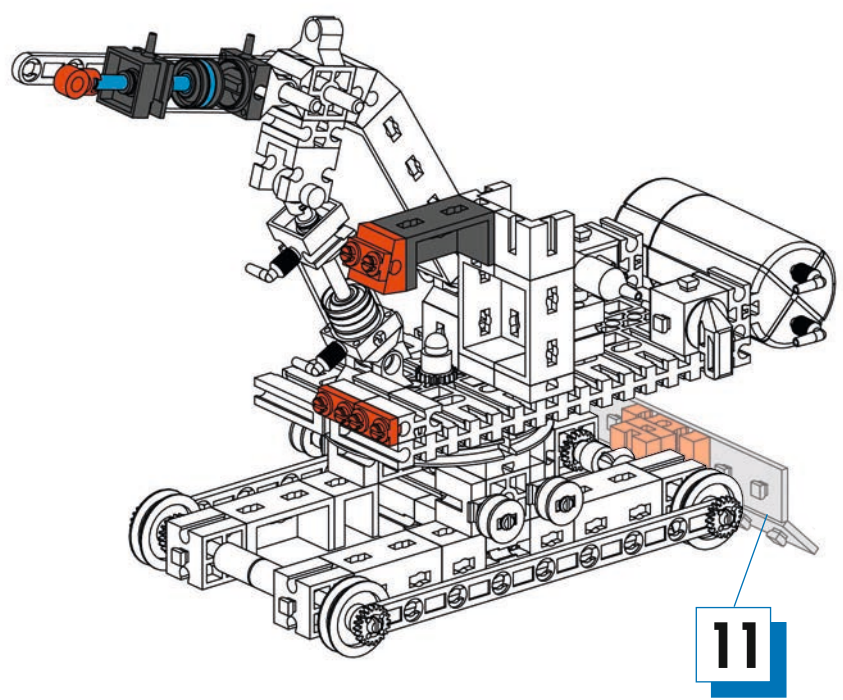
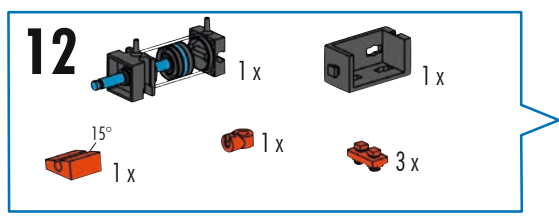
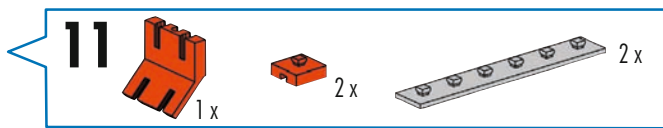
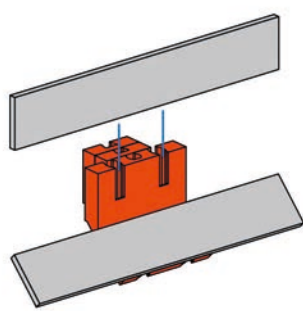
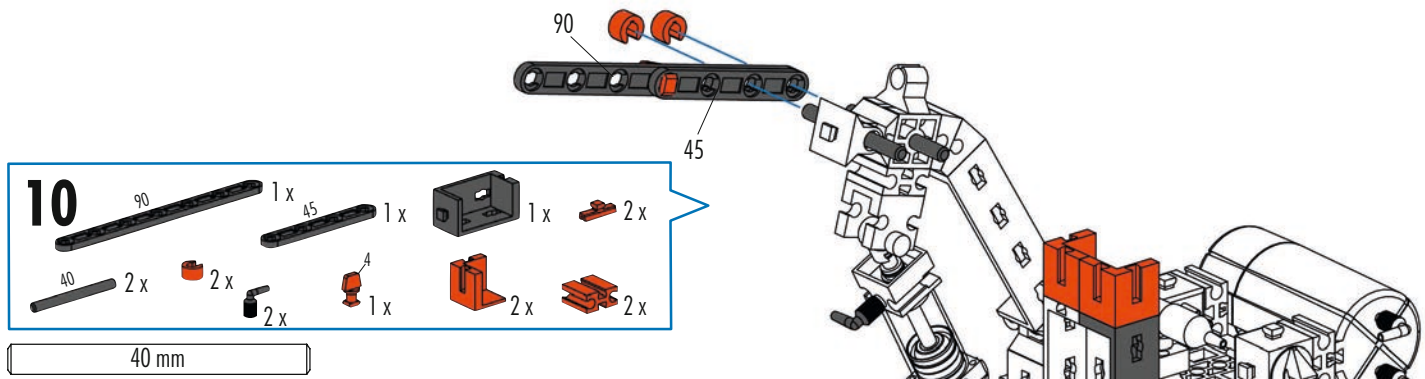

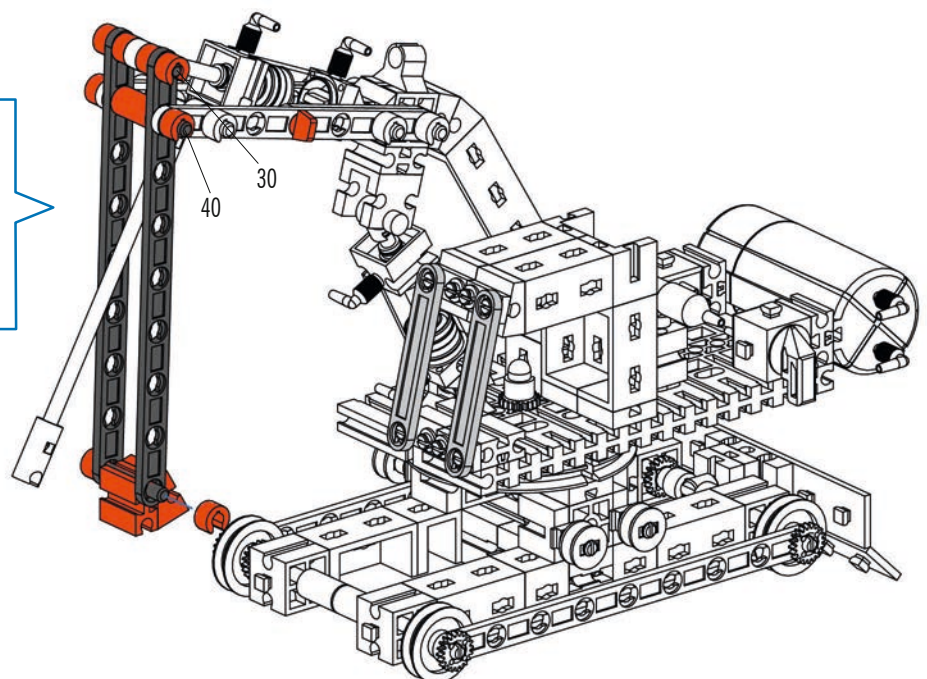
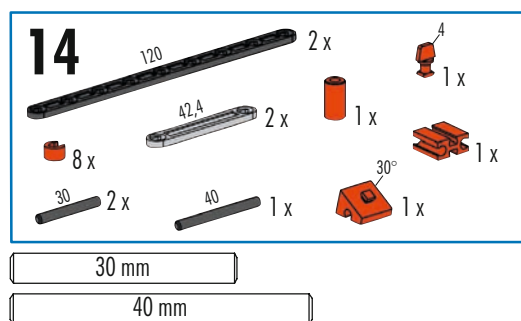
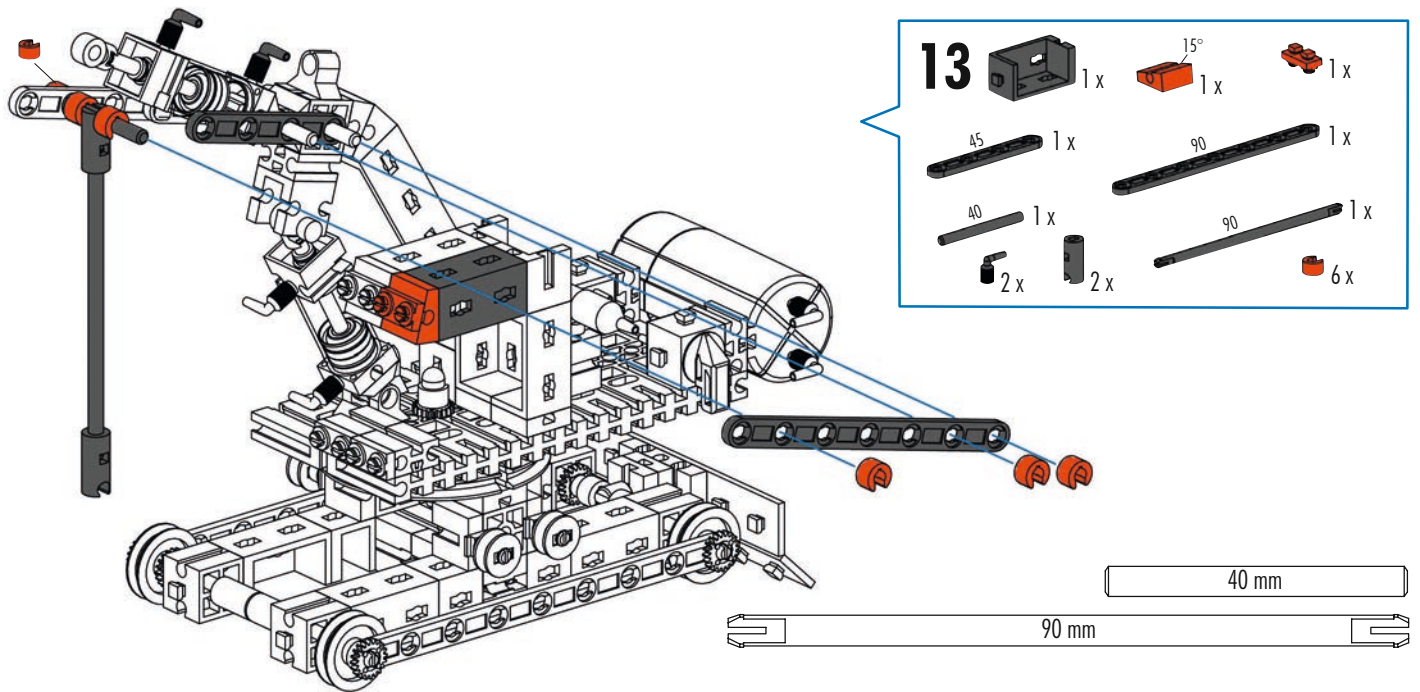



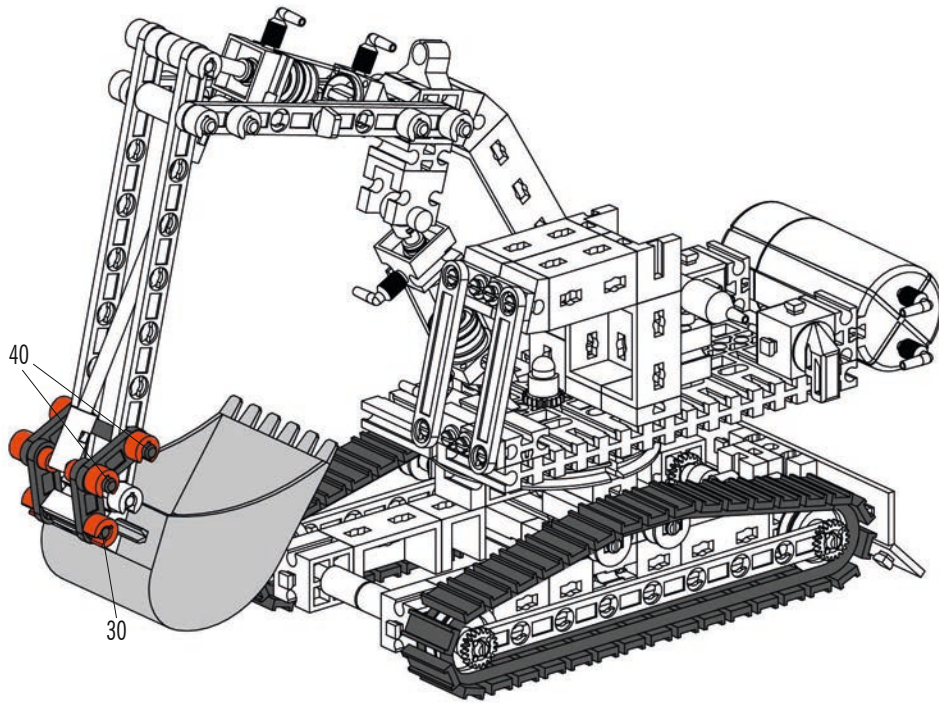

**15**

- 2 x [Track Link]
- 4 x [Pin 15]
- 2 x [Pin 2]
- 6 x [Pin 6]
- 1 x [Bucket]
- 1 x [Pin 30]
- 2 x [Pin 40]

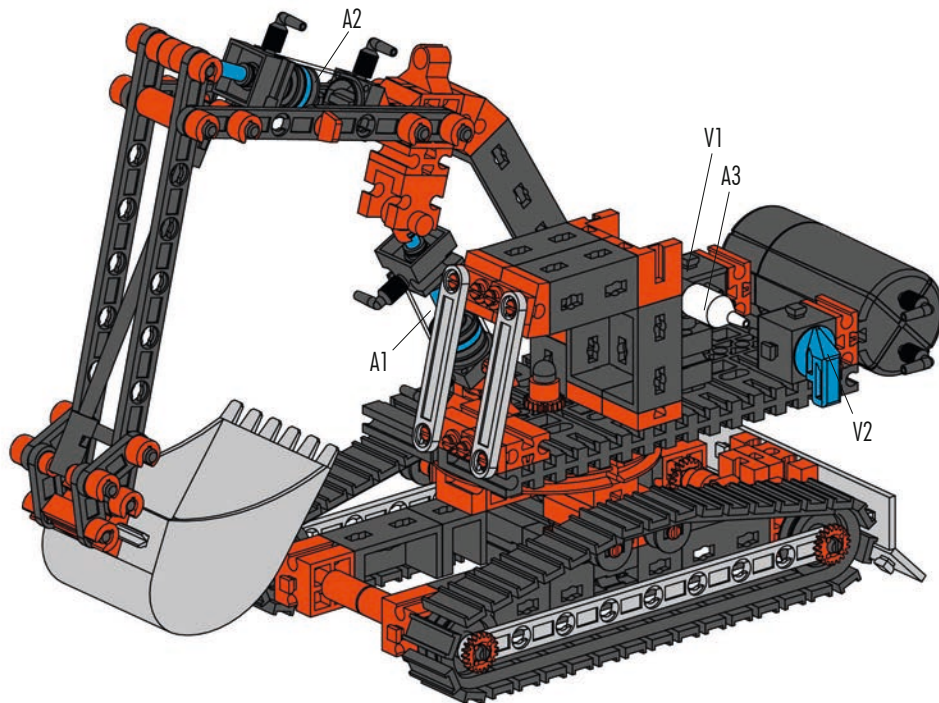



Schlauchanschlussplan  
Air line layout plan  
Plan de raccordement de conduits

Aansluitschema van slang  
Racor de empalme  
Plano de conexão de mangueira

Schema di allacciamento tubi  
Схема подключения шлангов  
软管连接图

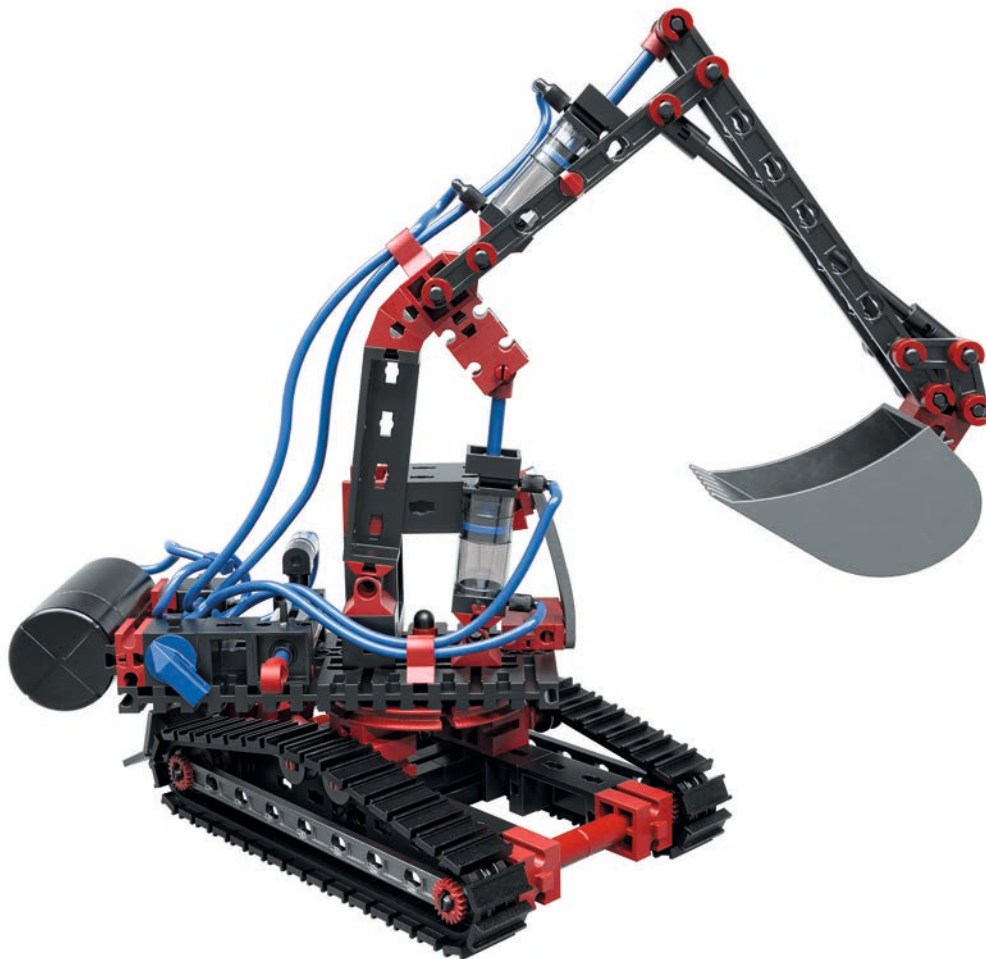
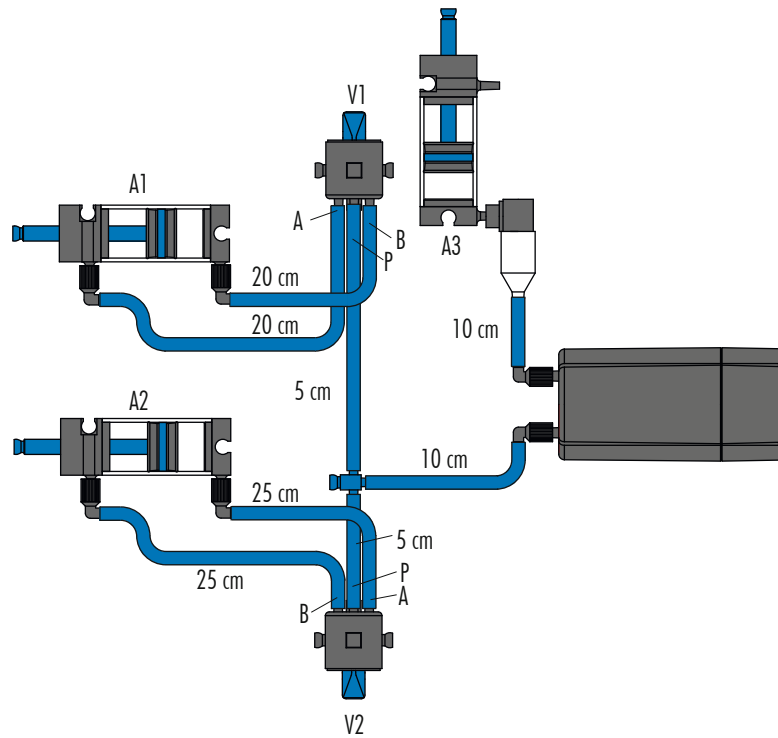

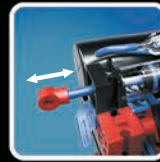

**fischertechnik** 

**PROFI**

fischertechnik GmbH  
Klaus-Fischer-Str. 1  
72178 Waldachtal  
Germany

Phone: +49 74 43/12-43 69  
Fax: +49 74 43/12-45 91

info@fischertechnik.de  
www.fischertechnik.de

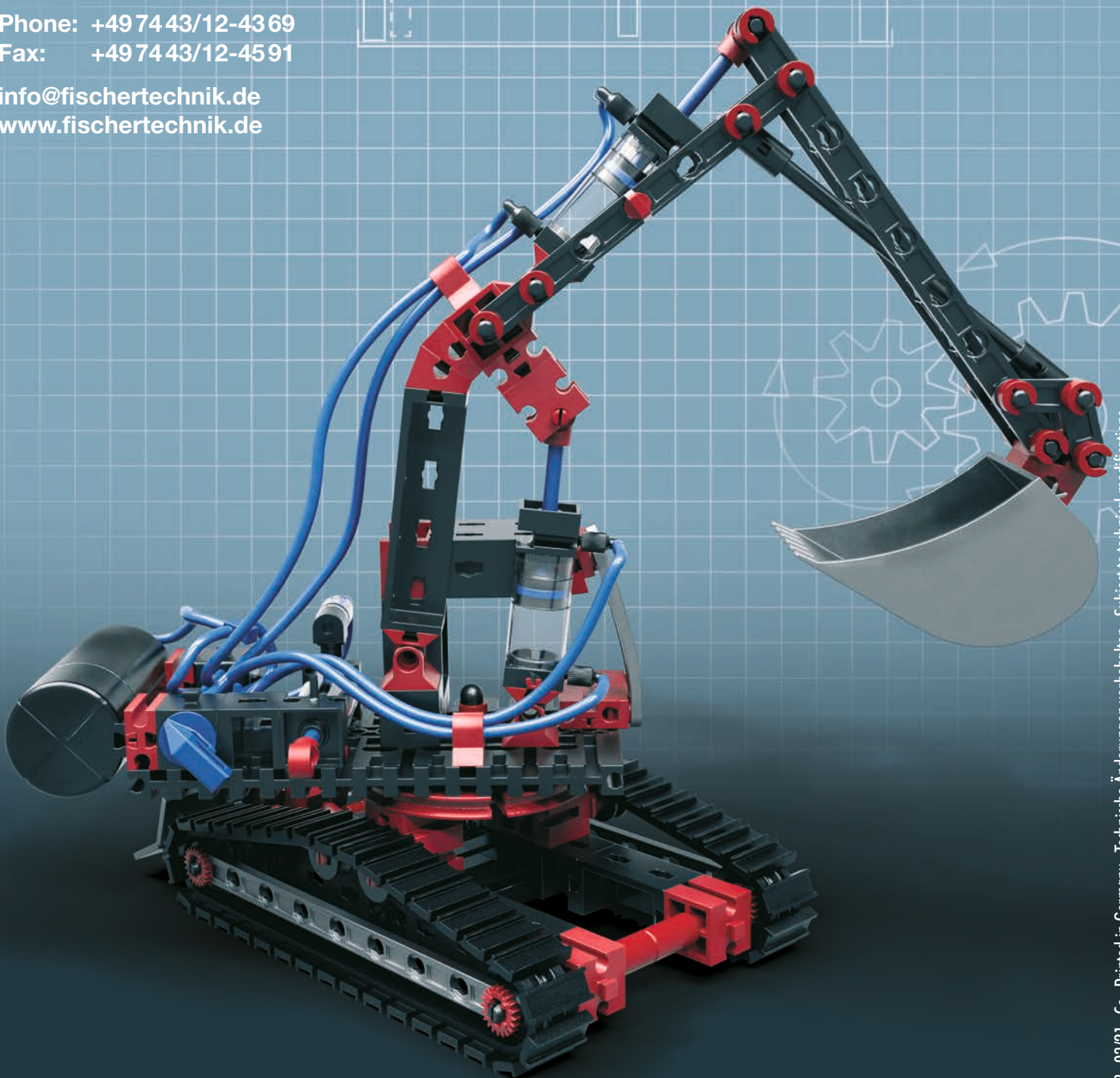

156848 · 03/21 · Co · Printed in Germany · Technische Änderungen vorbehalten · Subject to technical modifications

**Pneumatic Power**

**5 MODELS**