

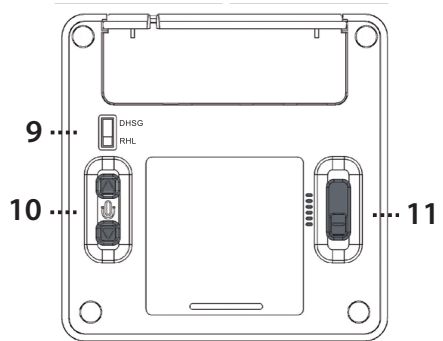

## A. Telephone Only base station

1. Battery Indicator
2. Auto answer disable button
3. Headset registration button
4. Online indicator
5. Power socket
6. EHS port
7. Telephone connector ('Tel' port)
8. Handset connector
9. EHS Selection switch
10. Microphone volume up/down
11. Wiring switch

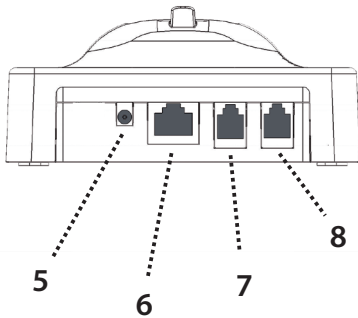
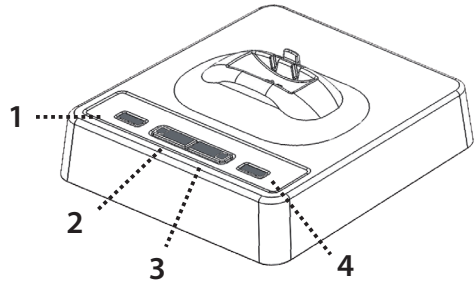

## B. Telephone/USB PC base station

1. Battery Indicator
2. PC button
3. Telephone (TEL) button
4. Online indicator
5. USB connector (PC port)
6. Power socket
7. EHS port
8. Telephone connector ('Tel' port)
9. Handset connector
10. EHS Selection switch
11. Microphone volume up/down
12. Wiring switch

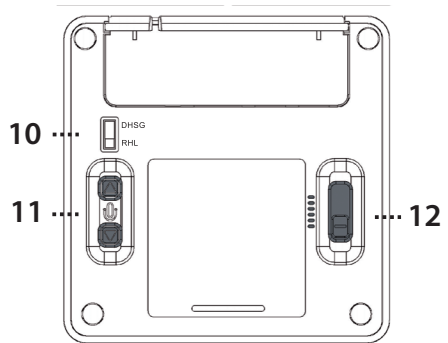
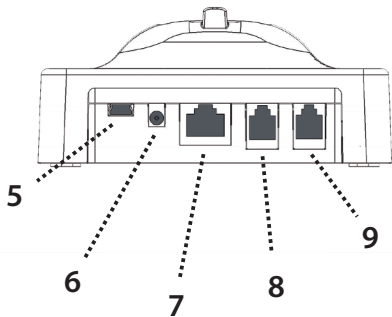
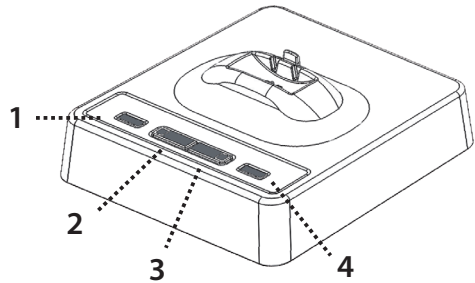

## A. Telephone/Bluetooth/USB PC base station

1. Battery Indicator
2. PC button
3. Bluetooth Button
4. Telephone (TEL) button
5. Online indicator
6. USB connector (PC port)
7. Power socket
8. EHS port
9. Telephone connector ('Tel' port)
10. Handset connector
11. EHS Selection switch
12. Microphone volume up/down
13. Wiring switch

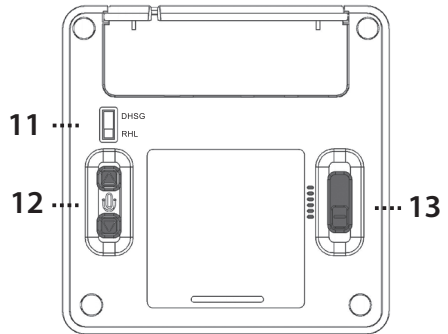
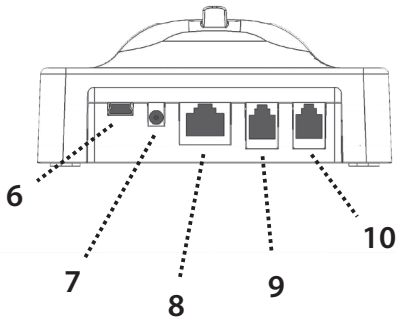
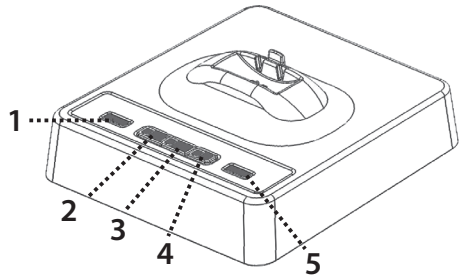

### C. IPN Over-The-Ear

1. Receive volume up/down
2. Mute
3. Headset ON/OFF
4. Noise cancelling boom
5. Replaceable earplug
6. Battery

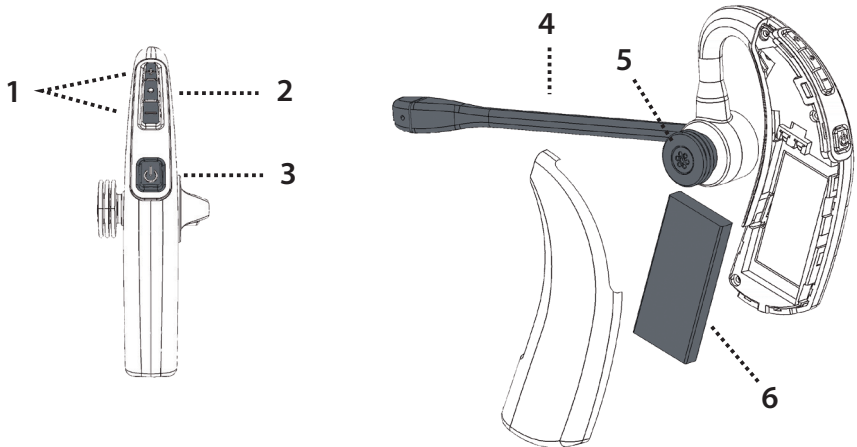
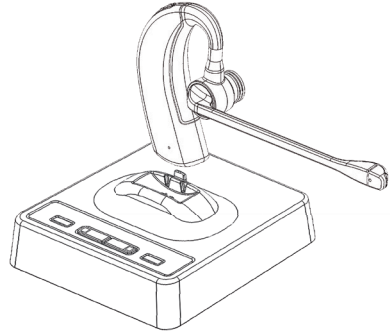

## D. IPN Monaural / IPN Binaural

1. Receive volume up/down
2. Mute
3. Headset ON/OFF
4. Noise cancelling boom
5. Battery

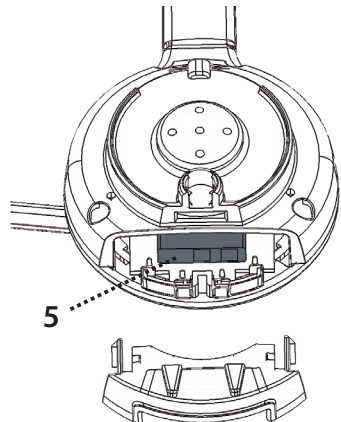
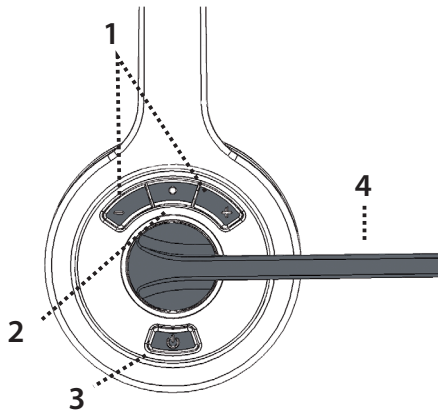

## Contents:

<b>1. Product description</b>	<b>8</b>
<b>2. Setup</b>	<b>9</b>
2.1 Connecting to a telephone or terminal with a headset port	9
2.2 Connection to a telephone or terminal without a headset port	9
2.3 Connecting to a compatible handset lifter (refer to your supplier)	9
2.4 Connecting EHS with DHSB protocols (refer to your supplier)	10
2.5 Connecting to a computer USB port (Models W970/W980/W985/W990/W995)	10
2.6 Connecting to a bluetooth device	10
2.7 Wearing style	10
<b>3. Operation</b>	<b>11</b>
3.1 Making and receiving calls	11
3.1.1 Making an outgoing call in telephone mode	11
3.1.2 Receiving an incoming call in telephone mode	11
3.1.3 Making an outgoing call in VOIP mode (Models W970/W980/W985/W990/W995)	11
3.1.4 Making or receiving a bluetooth call	12
3.2 Adjusting the ring volume	12
3.3 Muting the headset microphone	12
3.4 Headset transmitting volume setting	12
3.5 Adjusting headset receive volume	12
3.6 Out of range and reconnection	12
3.7 Battery level indication	13
3.8 Making a conference call	13
3.9 Registering headsets to the base	14
3.10 Using multiple headsets	14
3.11 Using the W9xx with Microsoft Lync (Models W970/W980/W985/W990/W995)	14
3.12 Switching Off Auto Pickup Mode (Telephone only base station)	15
3.13 Overview of audio signals	15
<b>4. Troubleshooting</b>	<b>15</b>

## 1. Product description

The IPN DECT is a fully wireless headset solution offering the user the ability to work 'handsfree' with true wireless mobility.

Main features:

- DECT wireless headset solution
- Universal headset base
- Up to 9 hours talk time without recharging
- Eco-Low Radiation DECT with dynamic power adjustment
- Auxiliary port for connecting handset lifter or electronic hookswitch device
- Noise cancelling microphone for reduced background noise
- Secure high quality audio
- Receive volume control on headset
- Mute button on headset
- Talk button with LED on headset
- Magnetic charging unit
- Operating Range up to 400m/1300 ft (Over-the-ear headset up to 300m)
- 'Out of range' warning
- DECT 6.0/GAP compatible
- DHSG protocol
- PC/USB connectivity \* (Models W970/W980/W985/W990/W995)
- Bluetooth device connectivity (Models W990/W995)
- Three way conferencing by connection additional headset

***\* Will connect to Apple Mac OS X or PC running Windows XP, Windows Vista, Windows 7, 8 & 10.***



## 2. Setup

- Connect the power adaptor supplied with the product to the base unit.  
The base power LED with light.

NOTE: The first time you use your headset, it is recommended that the headset is charged for a minimum of 4 hours before use.

### 2.1 Connecting to a telephone or terminal with a headset port

- Using the headset cord supplied with the product, connect the 'Tel' port on headset base with the headset port on your telephone.
- Use the power adaptor supplied with the product to connect the headset base to a power socket.
- You may need to adjust the wiring switch that is located on the bottom of the headset Base to find the correct wiring for your device.

### 2.2 Connecting to a telephone or terminal without a headset port

- Using the headset cord supplied with the product, connect the 'Tel' port on headset base with the 'handset' port on your telephone.
- Connect the telephone handset cord to the handset port on the headset base.
- Use the power adaptor supplied with the product to connect the headset base to a power socket.
- You may need to adjust the wiring switch that is located on the bottom of the headset base to find the correct wiring for your device.

### 2.3 Connecting to a compatible Handset Lifter (refer to your supplier)

- Fit the handset lifter to your telephone as indicated in its user guide.
- Connect the handset lifter to the 'AUX' port located on the back of the Headset Base.
- Ensure that the EHS selection switch is set to 'RHL'.

## 2.4 Connecting EHS with DHSG protocols (refer to your supplier)

- Connect the IPN DHSG cable to your telephone as indicated in its user guide.
- Connect the IPN DHSG cable to the 'AUX' and 'Tel' ports located on the back of the headset base.
- Ensure that the EHS selection switch is set to 'DHSG'.

With the handset lifter or DHSG cable connected, you will be able to answer and end calls using the button located on the headset while away from your desk.

## 2.5 Connecting to a computer USB port (Models W970/W980 & W985 only)

- Connect the USB cable supplied with the product to the 'USB' port on the back of the headset base and to an available USB port on your computer.
- The computer should automatically recognize the device and install the correct drivers. Wait a few seconds before using the headset.

## 2.6 Connecting to a Bluetooth device

- Hold down the Bluetooth button on the base for three (3) seconds until the LED flashes
- On the **Bluetooth**® device, turn on the **Bluetooth**® feature. The **Bluetooth**® feature is usually found in the settings menu
- Select 'DECT Headset' from the device list. Once paired, the LED will stop flashing.

## 2.7 Wearing Style

The IPN W9xx series is available in three headset variants:

- IPN Over-the-ear
- IPN Over-the-head monaural
- IPN Over-the-head binaural

To replace the earplug of the IPN Over-the-ear headset, twist the earplug 90 degrees and pull the earplug towards you.

To replace the ear cushion of the IPN Over-the-head monaural or binaural, put your thumb on the top of the speaker and carefully pull the ear cushion at the bottom towards you.

### 3. Operation

#### 3.1 Making and Receiving Calls

##### 3.1.1 Making an outgoing call in Telephone mode

- Ensure that the 'TEL' button on top of the headset base is selected.
- Lift the headset from the base to start a call. If you are already wearing the headset, press the headset's 'ON/OFF' button. The base 'Online Indicator' LED will light. If a handset Lifter or Electronic Hookswitch device is connected to the headset base, the line will be seized. Otherwise, you will also need to activate the Headset port via your telephone terminal.
- Dial the telephone number on the telephone terminal
- After finishing the call, replace the headset on the base or press the ON/OFF button to disconnect. The 'Online indicator' LED will turn off.

##### 3.1.2 Receive an incoming call in Telephone mode.

- If there is an incoming call from the telephone line and the headset base is connected to a handset lifter or Electronic Hook switch device, the 'TEL' LED and 'headset' LED will flash, also a ring tone will be heard on the headset.
- Lift the headset from the base to answer the call. If you are already wearing the headset press the headset's 'ON/OFF' button . The base 'online indicator' LED will light. If a handset Lifter or Electronic Hookswitch device is connected to the headset base, the line will be seized. Otherwise, you will also need to activate the headset port via your telephone terminal.
- To end the call, replace the headset on the base or press the headset ON/OFF button.

##### 3.1.3 Making an outgoing call in USB/PC mode (Models W970/W980/W985/W990/W995)

- Ensure that the 'PC' button on top of the headset base is selected.
- Lift the headset from the base or press the headset's ON/OFF button if you are already wearing it and the base 'On line indicator' LED will light.
- After finishing your call, press the ON/OFF button to disconnect. The base 'Online indicator' LED will turn off.

### 3.1.4 Making or receiving a Bluetooth call

- Ensure that the 'Bluetooth' button on top of the headset base is selected.
- Lift the headset from the base or press the headset's ON/OFF button if you are already wearing it and the base 'On line indicator' LED will light.
- Make or answer the call on your bluetooth device ensuring that the DECT Headset is selected as your audio device
- After finishing your call, press the ON/OFF button on the headset or end call button on the bluetooth device to disconnect. The base 'Online indicator' LED will turn off.

### 3.2 Adjusting the Ringing Volume

When the headset is ringing to indicated an incoming call, you can adjust the ring volume using the volume control buttons located on the headset.

### 3.3 Muting The Headset Microphone

To mute the headset microphone when on a call, press the 'Mute' button on the headset. While the headset is in Mute mode, a short beep will be heard on the headset every 8 seconds. Press the 'Mute' button again to release the mute.

### 3.4 Headset transmitting volume setting

You can adjust the transmit volume of the headset by using the two buttons located on the bottom of the headset base.

### 3.5 Adjusting Headset Receive Volume

Use the volume control buttons on the headset to adjust the receive volume on your headset. You will hear a beep sound for each volume step Up or Down.

### 3.6 Out of range and reconnection

You will hear a warning tone in the headset when you walk out of range of the base. The

headset will be disconnected from the base and the call will be automatically placed on hold. If you move back inside the range of the base the headset will automatically reconnect.

### 3.7 Battery Level Indication

The four LED's (8) on the top of the headset base indicate the battery level of your headset.

Indication	Battery level
One LED flashing	< 20%
One LED on	20%-40%
Two LEDs on	40%-60%
Three LEDs on	60%-80%
Four LEDs on	80%-100%

### 3.8 Making A Conference Call

Your IPN DECT Headset allows for a second headset to be temporarily connected to the base so that you can have a three way conference call.

- Setup the call using the primary headset unit.
- Once on the call, place the second IPN DECT headset unit on the base charger.
- After one second, the 'Online indicator' LED of the new headset will turn on and the base 'Online indicator' LED will flash to indicate the headset is registering with base unit.
- Once the registering has completed, the base 'Online indicator' LED will stop flashing and the additional headset LED will flash.
- Once the registration has completed, a confirmation sound will be heard on the primary headset.
- Lift the additional headset from the base and it will enter talk mode.

NOTE: The additional headset will only remain registered to the base for the duration of the call. After the primary headset has ended the call, the unit will return to its normal state.

#### Models W970/W980/W985/W990/W995 only:

The IPN DECT headset also allows you to make a conference call between your normal phone and a computer. To activate this option hold down the PC/USB button on the base for four

seconds. The LED's of the PC/USB and TEL buttons will light. If one of the buttons is pressed again this function will be turned off.

### 3.9 Registering headsets to the base

Up to three headsets can be registered permanently to the W9xx base. You can register a new headset unit to your base using the following procedure.

- Press and hold the 'TEL' or 'Registration' button on the headset base for five seconds to enter the registration mode. The 'TEL' LED will flash to indicate it is in registration mode.
- Press and hold the 'Headset ON/OFF' button on the headset for five seconds for the headset to enter registration mode.
- The headset will now be registered to the base which will take around 30 seconds. When the registration has completed, the base 'TEL' LED will stop flashing.

The additional 2 auxiliary headsets can be registered using the same procedure but instead of the 'TEL' button, use the microphone 'Up' button for headset 2 and the microphone 'Down' button for headset 3. These can be found on the underside of the headset base.

### 3.10 Using multiple headsets

If you have more than one headset registered to the W9xx base, the first headset to be turned on becomes the primary headset and takes control of the base. Another headset can then join and leave the call by the user pressing their headset buttons, but only the primary headset can end the call. NOTE: Only one of the two additional headsets can connect at any one time.

### 3.11 Using the IPN W9xx with Microsoft Lync (Models W970/W980/W985/W990/W995)

When your W9xx is connected to a PC using the USB cable, it can interact with Microsoft Lync/Skype For Business communication software installed on your PC. The headset button can be used to answer and end a call and if you activate and finish a call using the desktop software the headset will automatically turn on and turn off.

This function can be enable or disable as follows:

**To enable MS Lync/Skype For Business** - Press USB and microphone '+' buttons together for 3 seconds. The USB LED will flash twice (fast) 6 times to confirm the function is enabled.

**To disable MS Lync/Skype For Business** - Press USB and microphone '-' buttons together for 3 seconds. The USB LED will flash 6 times to confirm the function is disabled.

Default setting is MS Lync/Skype For Business disabled.

### 3.12 Switching Off Auto Pickup Mode

#### **Telephone Only base station**

The headset turns on automatically when taking the headset from the base. This function can be disabled. If the 'auto answer disable' button (2) is pressed, the LED will light and the headset auto answer mode will be disabled.

#### **Telephone/USB PC base station**

On the Telephone/USB PC headset models the auto answer can be toggled on and off by pressing the headset volume Up and down buttons together for 3 seconds.

- LED will flash slowly to show Auto Answer ON
- LED will flash quickly to show Auto Answer OFF

Default setting is Auto Answer OFF.

### 3.13 Overview of audio signals

Action	Audio indication
Low battery	2 rapid beeps (60 sec repeat)
Nearly out of range	2 beeps
Out of range	2 pitch tone
Back in range	4 rapid beeps
Receiver volume up/down	1 beep
Mute on	2 pitch tone (8 sec repeat)
Mute off	1 beep
Ringer (EH device)	Multi tone (2 sec repeat)

#### **4. Troubleshooting**

- Q. I have connected my headset base to my telephone terminal but the headset is not working.
- A. Make sure that the battery has been properly charged.
- Q. The headset is working but I cannot hear telephones calls correctly.
- A. Ensure that you have the correct wiring setting by adjusting the switch on the bottom of the headset base.
- Q. When the headset's ON/OFF button is pressed, the handset lifter lifts the handset but I cannot hear the call on the headset.
- A. Ensure that the headset base is connected to the telephone's handset port and not the headset port (If the telephone has one).

#### **Health and safety instructions**

Please read the following safety and operational instructions before using your IPN headset product. Please keep these instructions for your reference. When using this product, these basic safety precautions and warnings should be followed to reduce the risk of fire, electric shock, injury to persons and damage to property.

#### **General**

Operating, charging and storage temperature is 32°F to 104°F (0°C to 40°C).

#### **Warnings**

- CHILDREN. Never allow children to play with the product – small parts may be a choking hazard.
- Plug the AC adapter into the outlet nearest the equipment that is easily accessible.
- To reduce the risk of electric shock, explosion or fire, use only the supplied charger or Class 2 AC adapter to charge the headset. Ensure that the voltage rating (e.g. 120V, 60 Hz) corresponds to the power supply you intend to use.
- For safety reasons always tie back long hair that might get caught in the headset.



- Do not disassemble the product or AC adapter as this may expose you to dangerous voltages or other risks. Incorrect reassembly can cause electric shock or fire when the product is subsequently used.
- Do not insert anything into the product because this may cause damage to the internal components or cause injury to you.
- Avoid contact with liquids. Do not locate this product near water, for example, near a bathtub, or sink, in a wet basement, or near a swimming pool.
- Discontinue use of product and contact IPN Headsets if the product overheats, has a damaged cord or plug, if the product has been dropped or damaged, or if the product has come into contact with liquids.
- This product should never be placed over or near a heat register and should not be placed in locations without which do not have proper ventilation.
- If you experience a skin irritation after using this product, discontinue use and contact IPN Headsets.
- Exposure to high volume sound levels or excessive sound pressure may cause temporary or permanent damage to your hearing. Although there is no single volume setting that is appropriate for everyone, you should always use your headset with the volume set at moderate levels and avoid prolonged exposure to high volume sound levels. The louder the volume, the less time is required before your hearing could be affected. You may experience different sound levels when using your headset with different devices. The device you use and its settings affect the level of sound you hear. If you experience hearing discomfort, you should stop listening to the device through your headset and have your hearing checked by your doctor.

To protect your hearing, some hearing experts suggest you:

1. Set the volume control in a low position before putting your headset on your ears and use as low volume as possible.
2. Avoid turning up the volume to block out noisy surroundings. Whenever possible, use your headset in a quiet environment with low background noise.
3. Limit the amount of time you use headsets at high volume levels.
4. Turn the volume down if the sound from the headset prevent you from hearing people speaking near you.

To avoid the risk of electric shock, explosion, fire or leakage of corrosive or toxic chemicals, please observe the following charging and battery warnings:

### **Charging warnings**

- Use only the charger supplied by IPN Headsets to charge the product. Do not use the charger for any other purpose. Ensure that the voltage rating corresponds to the power supply you intend to use.
- Charge the headset according to the instructions supplied with the unit.
- Plug the AC adapter or charger into an outlet that is near the equipment and will be easily accessible.
- Never charge the battery where the temperature may fall below 0°C (32°F) or rise above 40°C (104°F) – for example in an unattended motor vehicle.
- Avoid charging the battery while it is unattended.

### **Headset battery warnings**

The headset is equipped with a replaceable battery. To reduce the risk of fire or injury to persons read and follow these instructions.

Do not attempt to open battery in a fire. The battery may explode. Check the local laws for disposal instructions.

Do not open or mutilate the battery. There may be corrosive materials which can cause damage to eyes or skin and may be toxic if swallowed.

Charge the headset according to the instructions supplied with the headset.

RECYCLING: the battery used in your headset must be recycled or disposed of properly. Contact your local recycling centre for proper disposal of your headset.

## IMPORTANT SAFETY INSTRUCTIONS

Do not use this equipment in places where volatile or explosive materials may be present. This equipment will be inoperable if mains power fails. For indoor use only.

When using your telephone equipment, basic safety precautions should always be followed to reduce the risk of fire, electric shock and injury to persons, including the following:

- Do not use this product near water, for example a bath tub, wash bowl, kitchen sink or laundry tub, in a wet basement or near a swimming pool.
- Avoid using a telephone (other than a cordless type) during an electrical storm. There may be a remote risk or electric shock from lightning.
- Do not use the telephone to report a gas leak in the vicinity of the leak.
- Use only the power cord and batteries indicated in this manual. Do not dispose of batteries in a fire. They may explode. Check with local codes for possible special disposal instructions.

### CAUTION:

Risk of explosion if battery is replaced by an incorrect type.

**Dispose of used batteries according to instructions.**

**Use only with (IPN W970 , IPN W980 and IPN W985) (3.7 V, 200 mAh Li-ion rechargeable battery).**

Supplied adaptor with ferrite must be used with this device to ensure compliance with the class B FCC limits.

This device complies with Part 15 of the FCC rules. Operation is subject to the following two conditions: (1) This device may not cause harmful interference, and (2) this device must accept any interference received, including interference that may cause undesired operation.

**Warning:** Changes or modifications to this equipment not expressly approved by the party responsible for compliance could void the user's authority to operate the equipment.

**Note:** This equipment has been tested and found to comply with the limits for a class B digital device, pursuant to Part 15 of the FCC rules. These limits are designed to provide reasonable protection against harmful interference in a residential installation. This equipment generates, uses and can radiate radio frequency energy and, if not installed and used in accordance with the instructions, may cause harmful interference to radio communications.

However, there is no guarantee that interference will not occur in a particular installation. If this equipment does cause harmful interference to radio or television reception, which can be determined by turning the equipment off and on, the user is encouraged to try to correct the interference by one or more of the following measures:

- Reorient or relocated the receiving antenna.
- Increase the separation between the equipment and the receiver.
- Connect the equipment into an outlet on a circuit different from that to which the receiver is connected.
- Consult the dealer or an experienced radio/TV technician for help.

To maintain the compliance with FCC's RF exposure guideline, place the base unit at least 20 cm from nearby persons.

This equipment complies with Part 68 of the FCC rules and the requirements adopted by the ACTA. On the bottom of this equipment is a label that contains, among other information, a product identifier in the format US: AAAEQ##TXXXX. If requested, this number must be provided to the telephone company.

An applicable certification jacks Universal Service Order Codes (USOC) for the equipment is provided (i.e RJ9) in the packaging with each piece of approved terminal equipment. A plug and jack used to connect this equipment to the premises wiring and telephone network must comply with the applicable FCC Part 68 rules and requirements adopted by the ACTA. A compliant telephone cord and modular plug is provided with this product. It is designed to be connected to a compatible modular jack that is also compliant.

See installation instructions for details.

If this equipment IPN W9xx causes harm to the telephone network, the telephone company will notify you in an advance that temporary discontinuation of service may be required. But if advance notice isn't practical, the telephone company will notify the customer as soon as possible. Also, you will be advised of your rights to file a complaint with the FCC if you believe it is necessary.

The telephone company may make changes in its facilities, equipment, operations or procedures that could affect the operation of the equipment. If this happens the telephone company will provide advance notice in order for you to make necessary modifications to maintain uninterrupted service.

Should you experience trouble with this equipment in the US, please contact:

**Headsets.com, Inc.**

**211 Austin Street**

**San Francisco, CA 94109**

**Phone: 1-800-HEADSETS (1-800-432-3738) Mon-Fri 6:00-4:30 Pacific Time**

**Website: [www.headsets.com](http://www.headsets.com)**

For repair or warranty information. If the equipment is causing harm to the telephone network, the telephone company may request that you disconnect the equipment until the problem is resolved. Please follow instructions for repairing if any (e.g battery replacement section) otherwise do not alternate of repair any parts of the device except specified.

I) Connection to party line service is subject to state tariffs. Contact the state public utility commission, public service commission or corporation commission for information.

II) **Notice:** If your home has specially wired alarm equipment connected to the telephone line, ensure the installation of this IPN W9xx does not disable your alarm equipment. If you have questions about what will disable alarm equipment, consult your telephone company or a qualified installer. This equipment is hearing aid compatible.

**Save these instructions**

## Europe Declaration

This product is CE marked according to the provisions of the R and TTE directive (99/5/EC). This product is in compliance with the essential requirements and other relevant provisions of the directive 1999/5/EC.

Safety:	EN60950-01:2006+A11:2009
EMC:	EN301489-6 V1.3.1:2008-08
	EN301489-1 V1.8.1:2008-04
	EN55022:2006+A1
	EN55024:1998+A1+A2
	EN61000-3-2:2006
	EN61000-3-3:5005+A1+A2
RF:	EN301406 V2.1.1:2009-07
RF Safety:	EN50360:2001 (Headset)
	EN50385:2002 (Base)

Only to be used together with the delivered certified AC mains adaptor with a GS mark. Within the EU this product is intended to be used in Austria, Belgium, Denmark, Finland, France, Germany, Greece, Ireland, Italy, Luxembourg, The Netherlands, Portugal, Spain, Sweden, United Kingdom, Cyprus, Czech Republic, Estonia, Hungary, Latvia, Lithuania, Malta, Poland, Slovakia and Slovenia and within the EFTA in Iceland, Norway and Switzerland.

